

**PARTS
CATALOGUE
CATALOGO
DE REPUESTOS**

YBR125DX (22P2) COLOMBIA

1H22P-261S1

()



2012/2/29

NEWS NO.	DATE	COMMENT
PE0-MC-090012	Mar.,4,2009	MOD:YBR125DX(22P1/2/3) FIG.2 LIST/ILLUSTRATION. CORRECTION
PE0-MC-080106	Feb.,27,2012	MOD:YBR125DX(22P2) FIG.30 STAND & FOOTREST LIST REVISION

YBR125DX
CATALOGO DE REPUESTOS
©2008 por Yamaha Motor Co., Ltd.
1ª edición, junio 2008
Todos los derechos reservados.
Toda reproducción o uso no autorizado
sin el consentimiento escrito de
Yamaha Motor Co., Ltd.
quedan expresamente prohibidos
Impreso en Japón.

YBR125DX
PARTS CATALOGUE
©2008 by Yamaha Motor Co., Ltd.
1st edition, June 2008
All rights reserved.
Any reprinting or unauthorized use
without the written permission of
Yamaha Motor Co., Ltd.
is expressly prohibited.
Printed in Japan.

PROLOGO

Este catálogo de repuestos corresponde a las piezas para el o los modelos que figuran en la página de portada. Al formular el pedido de repuestos, se ruega citar este catálogo y especificar correctamente el número y el nombre de las piezas.

1. Las modificaciones y agregados que se hayan realizado después de la edición de este Catálogo de Repuestos, serán anunciados en las Informaciones de Recambios. Es recomendable que se hagan las correcciones necesarias en el Catálogo de Repuestos de acuerdo con las Informaciones de Recambios.

2. Abreviaciones

En este. Catálogo de Repuestos se emplean las siguientes abreviaciones.

“UR” Usar el número de partes especificado

“UN” Usar la cantidad necesaria

“AP” Piezas sustitutivas

“LM” Fabricación local (Hay que pedir los repuestos en las cercanías)

“F#” N° de bastidor (N° aplicable a la máquina)

“O/S” Sobredimensionado

3. La cantidad de componentes para el montaje

- Los componentes, suministrados como conjunto, se describen con un punto (.) que precede al nombre del parte como se indica a continuación.
- La numeración que aparece a la derecha de cada descripción indica la cantidad de partes por cada unidad de conjunto.

CODIGO N°	DESCRIPCION	CANT.	OBSERVACIONES
2F5-83310-60	ENSAMBLAJE DE LA LUZ	2	
115-83311-60	.BOMBILLA (6V-18W)	1	

4. Los colores de los componentes se indican como sigue en la columna de “OBSERVACIONES”.

CODIGO N°	DESCRIPCION	CANT.	OBSERVACIONES
2N4-24110-00-X5	COMP. DEL TANQUE	2	MXR
3J1-24240-10	.GRAFICO, DEL TANQUE	1	PARA MXR

5. Debe tenerse en cuenta que las ilustraciones sirven como guía para la búsqueda de los números de partes y no deben usarse para el montaje. Durante el montaje, se recomienda usar el manual de taller correspondiente.

6. EL asterisco (*) antes del número de referencia indica los elementos modificados después de la primera edición.

FOREWORD

This Parts Catalogue is related to the parts for the model(s) on the cover page. When you are ordering replacement parts, please refer to this Parts Catalogue and quote both part numbers and part names correctly.

1. Modifications or additions which have been made after the issue of the Parts Catalogue will be announced in the Parts News.

It is advisable that you make the necessary corrections to the Parts Catalogue according to the Parts News.

2. Abbreviations

The following abbreviations are used in this Parts Catalogue.

“UR” Use specified parts number.

“UN” Use as many as needed.

“AP” Alternate Parts

“LM” Locally Made (Parts need to be ordered locally)

“F#” Frame No. (Applicable machine No.)

“O/S” Over Size

3. The number of components for assembly

- Parts, which are to be supplied in an assembly, are listed with a dot (.) in front of the part name as shown below.
- The numeral appearing to the right of each component part indicates the quantity of parts for each assembly unit.

PART NO.	DESCRIPTION	Q'TY	REMARKS
2F5-83310-60	FRONT FLASHER LIGHT ASSY	2	
115-83311-60	.BULB (6V-18W)	1	

4. Applicable colours of graphics are represented in the “REMARKS” as shown below.

PART NO.	DESCRIPTION	Q'TY	REMARKS
2N4-24110-00-X5	FUEL TANK COMP.	2	MXR
3J1-24240-10	.GRAPHIC, FUEL TANK	1	FOR MXR

5. Note that the illustrations for reference in finding parts numbers are not to be used for assembling. When assembling, please use the applicable service manual.

6. The asterisk (*) before a reference number indicates modified items after the first edition.

PROLOGO

7. Números de serie

Nº de Serie del bastidor

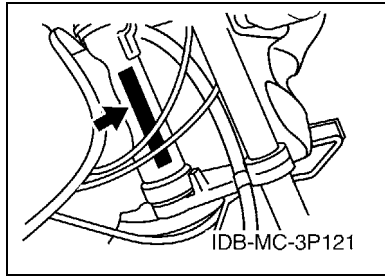

Nº de Serie del motor

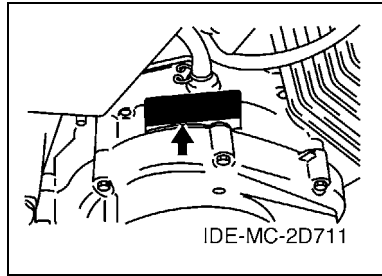

8. Códigos de color aplicables (El símbolo (*) muestra el color de modelo.)

Abreviatura	Nombre de color	Código de color
DPBMC(*)	DEEP PURPLISH BLUE METALLIC C	0564
HTS(*)	HI TECH SILVER	00WG
S3	SILVER 3	0791
VRC1(*)	VIVID RED COCKTAIL 1	0121
VRC7	VIVID RED COCKTAIL 7	0580
YB(*)	YAMAHA BLACK	0033

9. Nº de serie inicial aplicable

Nº de Serie del bastidor

Nº de serie	Nombre de la columna de cantidades	Código de Modelo

Nº de Serie del motor

Nº de serie	Nombre de la columna de cantidades	Código de Modelo

FOREWORD

7. Applicable Serial No.

Frame Serial No.

Engine Serial No.

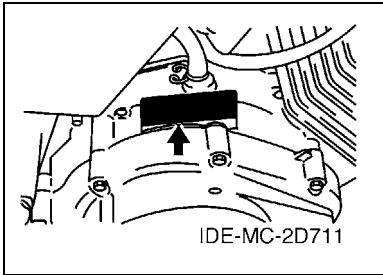
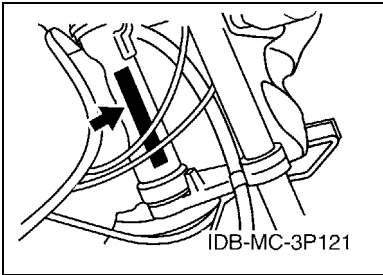

8. Applicable Colour Code (The (*) mark shows Model colour.)

Abbreviation	Colour Name	Colour Code
DPBMC(*)	DEEP PURPLISH BLUE METALLIC C	0564
HTS(*)	HI TECH SILVER	00WG
S3	SILVER 3	0791
VRC1(*)	VIVID RED COCKTAIL 1	0121
VRC7	VIVID RED COCKTAIL 7	0580
YB(*)	YAMAHA BLACK	0033

9. Applicable Starting Serial No.

Frame Serial No.

Serial No.	Name Of Q'ty Column	Model Code

Engine Serial No.

Serial No.	Name Of Q'ty Column	Model Code

CONTENIDO

MOTOR

CILINDRO	1
CIGUENAL & PISTON	2
VALVULA	3
ARBOL DE LEVAS & CADENA	4
BOMBA DE ACEITE	5
ADMISION	6
CARBURADOR	7
DESCARGA	9
CARTER	10
CUBIERTA DE CARTER 1	11
ARRANQUE	12
EMBRAGUE DEL ARRANQUE	13
EMBRAGUE	14
TRANSMISION	15
LEVA DE CAMBIO & HORQUILLA	16
EJE DE CAMBIO & PEDAL	17

SHASIS

CUADRO	18
GUARDABARRO	19
CUBIERTA LATERAL	20
BRAZO TRASERO & SUSPENSION	21
DIRECCION	22
HORQUILLA DELANTERA	23
DEPOSITO DE COMBUSTIBLE	25
ASIENTO	28
RUEDA DELANTERA	30
CALIBRE FRENO DELANTERA	31
RUEDA TRASERA	32
MANILLAR & CABLE	34
CILINDRO MAESTRO DELANTERO	35
SOPORTE & APOYAPIE	36
GENERADOR	38
MOTOR DE ARRANQUE	39
LUZ DE DESTELLADOR	40
MEDIDOR	41
FARO DELANTERO	42
LUZ DE COLA	44
INTERRUPTOR DE MANILLAR&PALANC	45
EQUIPO ELECTRICO 1	46
EQUIPO ELECTRICO 2	47

INDICE

INDICE NUMERICO	48
-----------------------	----

CONTENTS

ENGINE

CYLINDER	1
CRANKSHAFT & PISTON	2
VALVE	3
CAMSHAFT & CHAIN	4
OIL PUMP	5
INTAKE	6
CARBURETOR	7
EXHAUST	9
CRANKCASE	10
CRANKCASE COVER 1	11
STARTER	12
STARTER CLUTCH	13
CLUTCH	14
TRANSMISSION	15
SHIFT CAM & FORK	16
SHIFT SHAFT	17

CHASSIS

FRAME	18
FENDER	19
SIDE COVER	20
REAR ARM & SUSPENSION	21
STEERING	22
FRONT FORK	23
FUEL TANK	25
SEAT	28
FRONT WHEEL	30
FRONT BRAKE CALIPER	31
REAR WHEEL	32
STEERING HANDLE & CABLE	34
FRONT MASTER CYLINDER	35
STAND & FOOTREST	36
GENERATOR	38
STARTING MOTOR	39
FLASHER LIGHT	40
METER	41
HEADLIGHT	42
TAILLIGHT	44
HANDLE SWITCH & LEVER	45
ELECTRICAL 1	46
ELECTRICAL 2	47

INDEX

NUMERICAL INDEX	48
-----------------------	----



5P42200-F010

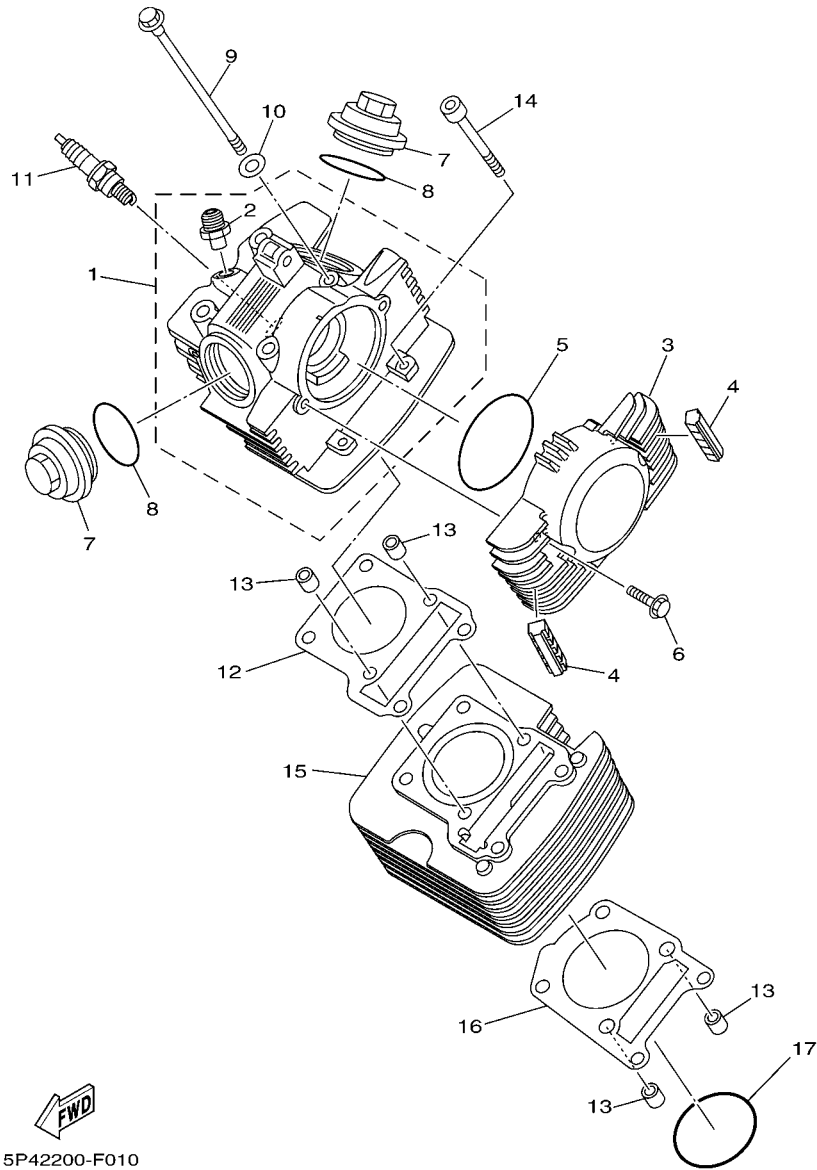
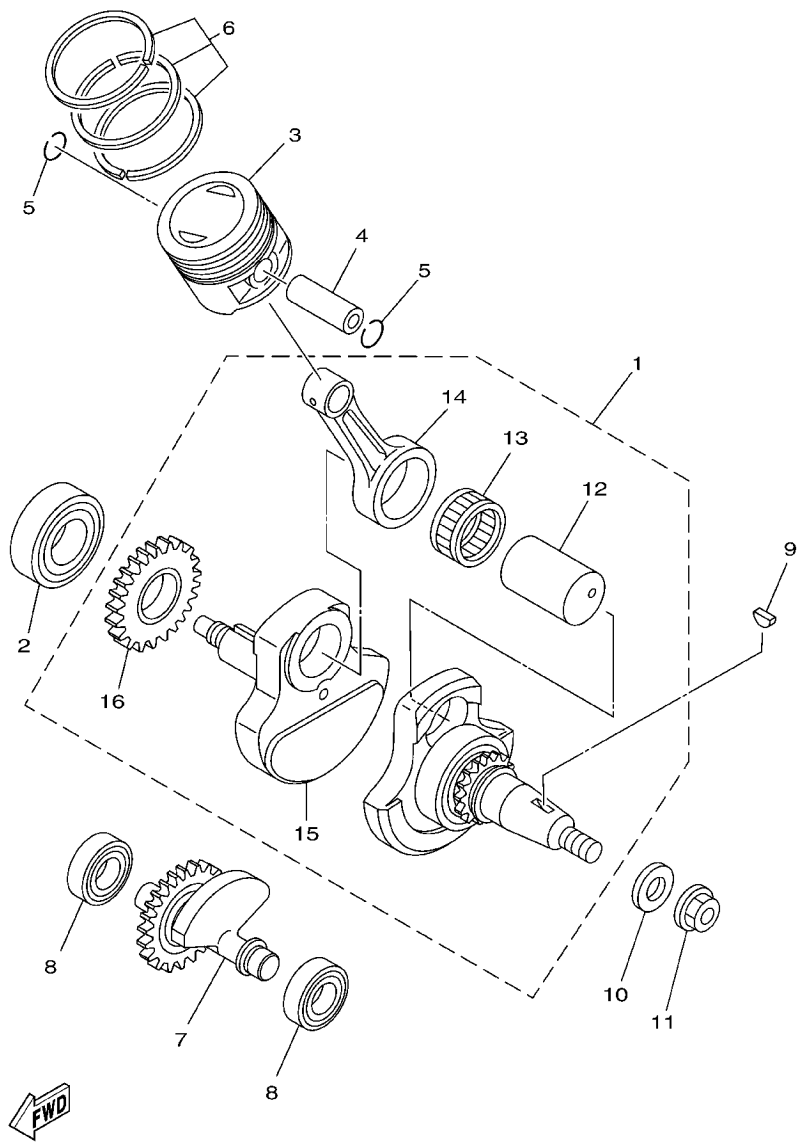

FIG. 1 CILINDRO

CYLINDER

REF. Nº	CODIGO Nº PART NO.	DESCRIPCION DESCRIPTION	22P2				OBSERVACIONES REMARKS
1	5YY-WE111-10	CULATA CILINDRO 1 HEAD, CYLINDER 1	1				
2	5YY-E465F-00	.JUNTA, 1 .JOINT, 1	1				
3	5YY-E1185-00	CUBIERTA CULATA CIL.LAT.1 COVER, CYLINDER HEAD SIDE 1	1				
4	4LS-E1161-00	AMORTIGUADOR 1 ABSORBER 1	2				
5	93210-79800	ANILLO O O-RING	1				
6	95027-06020	PERNO, DE BRIDA BOLT, FLANGE	2				
7	4LS-E1186-00	CUBIERTA CULATA CIL.LAT.1 COVER, CYLINDER HEAD SIDE 1	2				
8	93210-44889	ANILLO O O-RING	2				
9	90105-08886	TORNILLO BOLT, FLANGE	4				
10	90201-08609	ARANDELA PLANA WASHER, PLATE	4				
11	94700-00834	BUJIA (NGK CR7HSA) PLUG, SPARK (NGK CR7HSA)	1				
12	4LS-E1181-00	JUNTA, DE CULATA 1 GASKET, CYLINDER HEAD 1	1				
13	91810-14804	PASADOR DE CLAVIJA PIN, DOWEL	4				
14	90110-06850	TORNILLO ALLEN BOLT, HEXAGON SOCKET HEAD	2				
15	4LS-E1310-01	CILINDRO CYLINDER	1				
16	5YY-E1351-00	JUNTA, DE CILINDRO GASKET, CYLINDER	1				
17	93210-57897	ANILLO O O-RING	1				



3P12481D0201

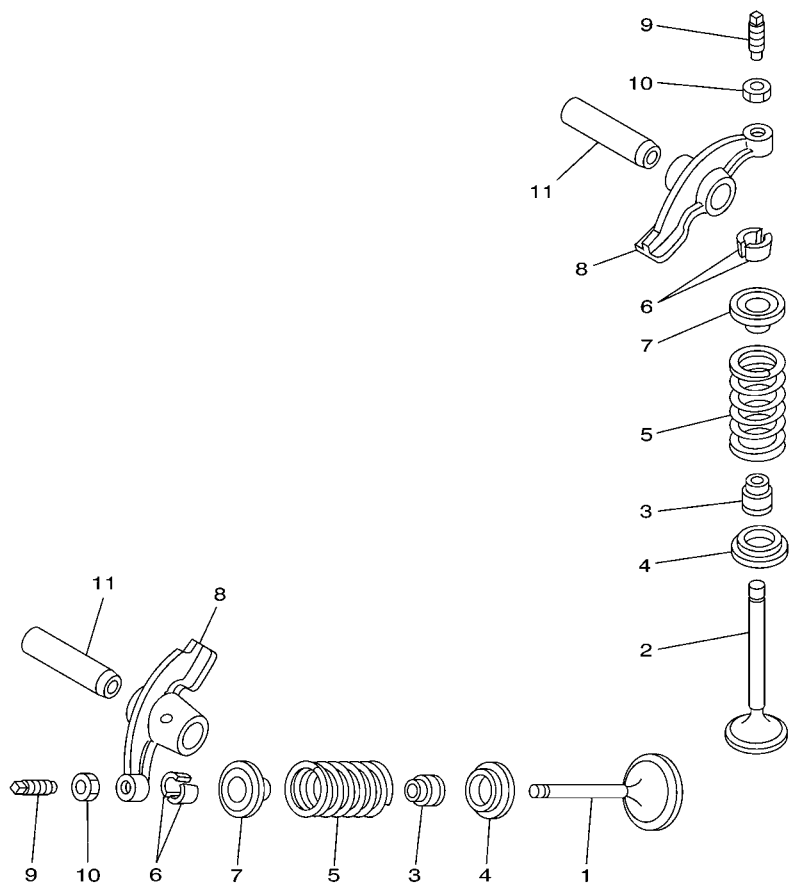

FIG. 2 CIGUENAL & PISTON CRANKSHAFT & PISTON

REF. Nº	CODIGO Nº PART NO.	DESCRIPCION DESCRIPTION	22P2				OBSERVACIONES REMARKS
1	5YY-E1400-20	CIGUENAL COMPLETO CRANKSHAFT ASSY	1				
2	93306-205XU	COJINETE BEARING	1				
3	4LS-E1631-01	PISTON (NORMA) PISTON (STD)	1				
	4LS-E1636-00	PISTON (0.50MM O/S) PISTON (0.50MM O/S)	1				AP
	4LS-E1638-00	PISTON (1.00MM O/S) PISTON (1.00MM O/S)	1				AP
4	2TK-11633-00	PASADOR, PISTON PIN, PISTON	1				
5	93450-16812	SEGURO CIRCLIP	2				
6	4LS-E1603-00	JUEGO DE ANILLOS (NORMA) PISTON RING SET (STD)	1				
	4LS-E1605-00	JUEGO DE ANILLOS (0.50MM O/S) PISTON RING SET (0.50MM O/S)	1				AP
	4LS-E1607-00	JUEGO DE ANILLOS (1.00MM O/S) PISTON RING SET (1.00MM O/S)	1				AP
7	4LS-E1500-02	COMPENSADOR COMPLETA BALANCER ASSY	1				
8	93306-202YD	COJINETE BEARING	2				
9	90280-03017	CUNA WOODRUFF KEY, WOODRUFF	1				
10	90201-122H1	ARANDELA PLANA WASHER, PLATE	1				
11	95707-12500	TUERCA DE BRIDA NUT, FLANGE	1				
12	4LS-E1681-00	.PASADOR MANIVELA 1 .PIN, CRANK	1				
13	93310-6290C	.COJINETE .BEARING	1				
14	4LS-E1651-01	.BIELA .ROD, CONNECTING	1				
15	4LS-E1422-00	.MANIVELA 2 .CRANK 2	1				
16	4LS-E1536-00	.ENGRANAJE TRACCION .GEAR, DRIVE	1				

FIG. 3 VALVULA

VALVE



REF. Nº	CODIGO Nº PART NO.	DESCRIPCION DESCRIPTION	22P2				OBSERVACIONES REMARKS
1	4LS-E2111-10	VALVULA DE ADMISION VALVE, INTAKE	1				
2	4LS-E2121-10	VALVULA DE ESCAPE VALVE, EXHAUST	1				
3	4LS-E2119-00	SELLO DE ACEITE VALVULA SEAL, VALVE STEM	2				
4	4LS-E2116-00	ASIENTO RESORTE DE VALVULA SEAT, VALVE SPRING	2				
5	5YY-E2113-00	RESORTE VALVULA INTERNA SPRING, VALVE INNER	2				
6	4LS-E2118-00	SÉGURO DE VALVULA COTTER, VALVE	4				
7	4LS-E2117-00	RETEN RESORTE DE VALVULA RETAINER, VALVE SPRING	2				
8	5YY-E2151-00	BRAZO DE BALANCIN DE VALVULA ARM, VALVE ROCKER	2				
9	4LS-E2159-01	TORNILLO DE AJUSTE DE VALVULA SCREW, VALVE ADJUSTING	2				
10	90170-05302	TUERCA NUT	2				
11	4LS-E2156-00	EJE DE BALANCIN SHAFT, ROCKER 2	2				



4LS1470-8030

FIG. 4 ARBOL DE LEVAS & CADENA CAMSHAFT & CHAIN

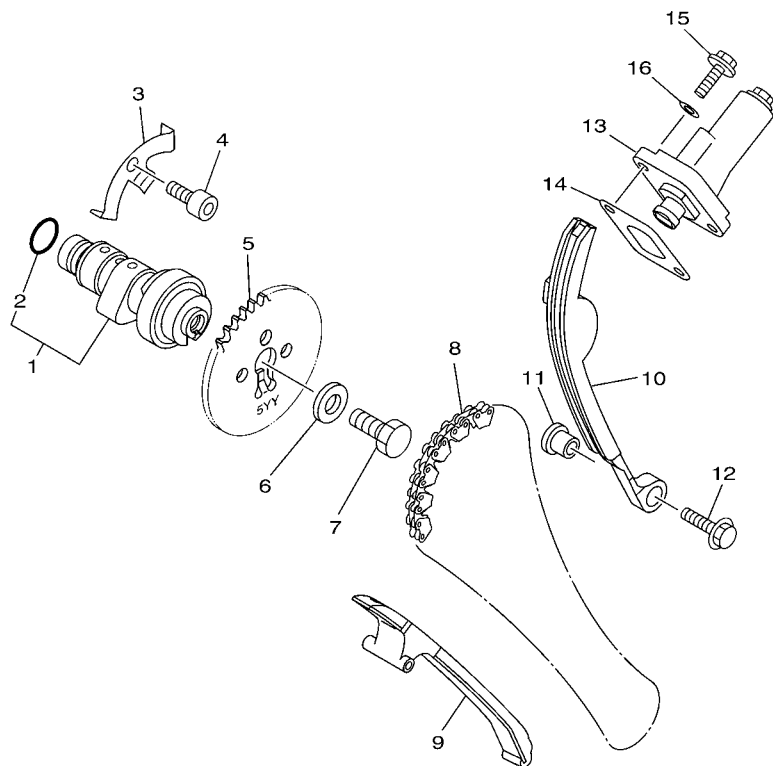

REF. Nº	CODIGO Nº PART NO.	DESCRIPCION DESCRIPTION	22P2				OBSERVACIONES REMARKS
1	5YY-E2170-00	ARBOL DE LEVAS COMPLETO 1 CAMSHAFT ASSY 1	1				
2	93210-108B1	.ANILLO O .O-RING	1				
3	4LS-E111F-00	PLACA PLATE	1				
4	90110-06810	TORNILLO ALLEN BOLT, HEXAGON SOCKET HEAD	1				
5	5YY-E2176-00	CATALINA DE CADENA SPROCKET, CAM CHAIN	1				
6	90201-08326	ARANDELA PLANA WASHER, PLATE	1				
7	90101-08590	TORNILLO BOLT	1				
8	94568-A0090	CADENA CHAIN	1				
9	5YY-E2231-00	TOPE DE GUIA 1 GUIDE, STOPPER 1	1				
10	5YY-E2241-00	TOPE DE GUIA 2 GUIDE, STOPPER 2	1				
11	4LS-E5598-00	COLLAR COLLAR	1				
12	90105-06812	TORNILLO BOLT, FLANGE	1				
13	5YY-E2210-20	TENSOR CADENA DE LEVA TENSIONER ASSY, CAM CHAIN	1				
14	5YY-E2213-00	EMPAQUE DE CAJA TENSOR GASKET, TENSIONER CASE	1				
15	95027-06016	PERNO, DE BRIDA BOLT, FLANGE	2				
16	90430-06817	JUNTA GASKET	2				



5P42200-F040

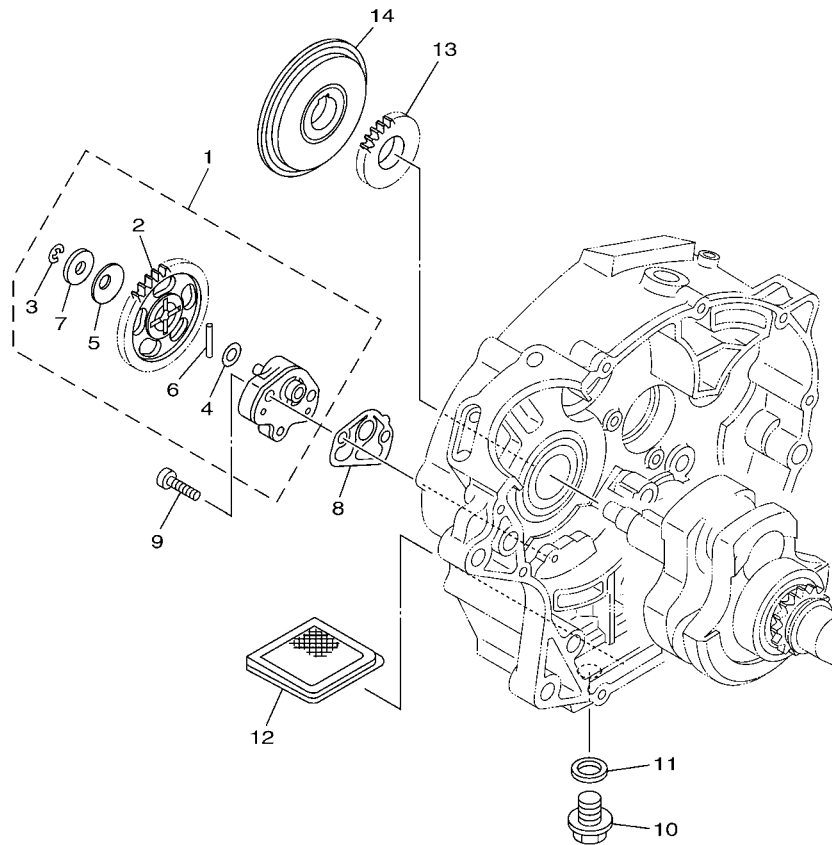

3P12481-D050

FIG. 5 BOMBA DE ACEITE OIL PUMP

REF. N°	CODIGO N° PART NO.	DESCRIPCION DESCRIPTION	22P2				OBSERVACIONES REMARKS
1	5YY-E3300-00	BOMBA DE ACEITE COMPLETA OIL PUMP ASSY	1				
2	5KA-E3325-20	.ENGRANAJE IMPULSOR DE BOMBA 1 .GEAR, PUMP DRIVEN	1				
3	99001-05600	.PRESILLA REDONDA .CIRCLIP	1				
4	90201-07641	.ARANDELA PLANA .WASHER, PLATE	1				
5	90208-07052	.ARANDELA DE RESORTE CONICO .WASHER, CONICAL SPRING	1				
6	93602-20800	.PASADOR DE CLAVIJA .PIN, DOWEL	1				
7	90201-07800	.ARANDELA PLANA .WASHER, PLATE	1				
8	4LS-E3329-00	EMPAQUE TAPA DE BOMBA GASKET, PUMP COVER	1				
9	90155-06800	TORNILLO CABEZA PLANA RAN. SCREW, FLAT FILLISTER	2				
10	90340-12097	TORNILLO DE DRENAJE PLUG, STRAIGHT SCREW	1				
11	90430-12227	JUNTA GASKET	1				
12	4LS-E3411-00	FILTRO DE ACEITE STRAINER, OIL	1				
13	4LS-E3324-00	ENGRANAJE TRACC. DE BOMBA(22T) GEAR, PUMP DRIVE (22T)	1				
14	4LS-E3451-00	FILTRE ROTATIVO FILTER,ROTARY	1				

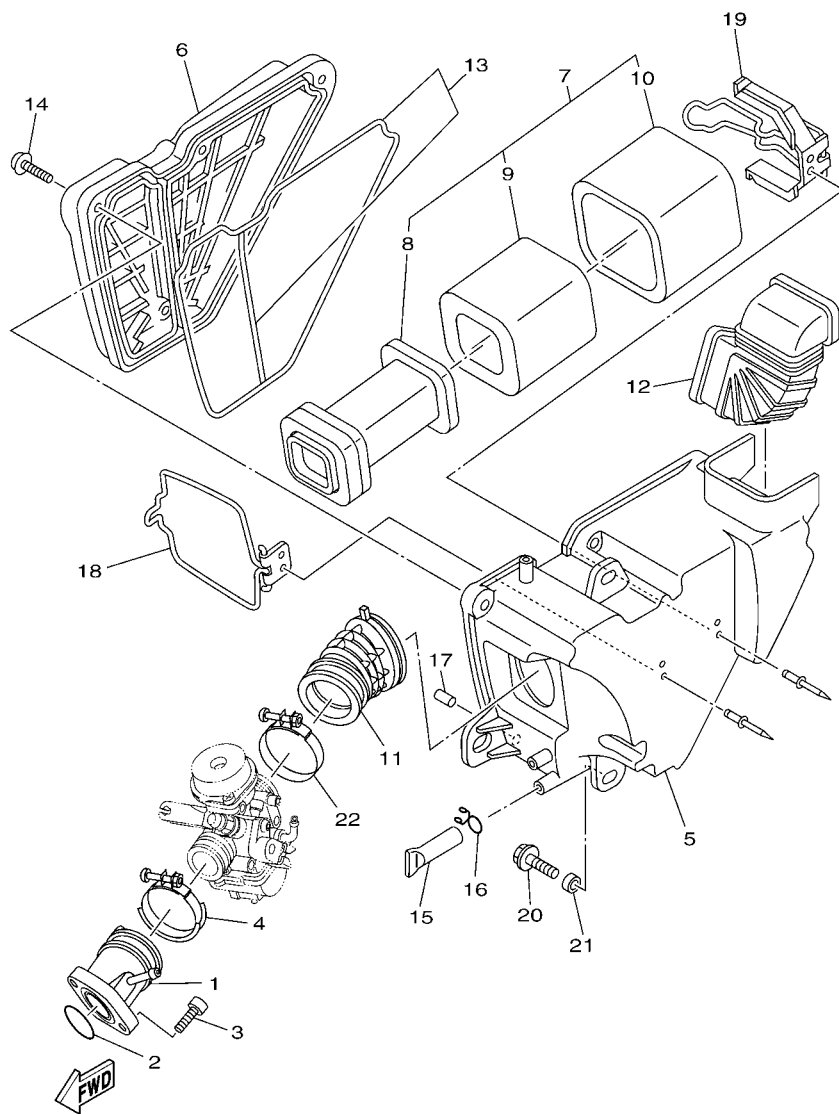

5P42200-F060

FIG. 6 ADMISION

INTAKE

REF. N°	CODIGO N° PART NO.	DESCRIPCION DESCRIPTION	22P2				OBSERVACIONES REMARKS
1	5YY-E3586-00	TOBERA DE CARBURADOR 1 JOINT, CARBURETOR 1	1				
2	93210-30611	ANILLO O O-RING	1				
3	91317-06020	PERNO BOLT	2				
4	90450-44046	BRIDA, MANGUERA HOSE CLAMP ASSY	1				
5	5YY-E4411-00	CAJA FILTRO DEL AIRE 1 CASE, AIR CLEANER 1	1				
6	5YY-E4412-00	TAPA CAJA DEL FILTRO 1 CAP, CLEANER CASE 1	1				
7	5TS-E4450-00	ELEMENTO COMP.FILTRO DE AIRE ELEMENT ASSY, AIR CLEANER	1				
8	5TS-E4458-00	.GUIA .GUIDE	1				
9	5TS-E4451-00	.ELEMENTO DEL FILTRO DEL AIRE .ELEMENT, AIR CLEANER	1				
10	5TS-E4461-00	.ELEMENTO COMPLETO .ELEMENT, AIR CLEANER 2	1				
11	5YY-E4453-00	UNION DEL FILTRO DEL AIRE 1 JOINT, AIR CLEANER 1	1				
12	5YY-E4437-00	CONDUCTO DUCT	1				
13	5TS-WE445-10	ELEMENTO DE FILTRO DE AIRE AIR CLEANER ELEMENT SET	1				
14	97607-06225	TORNILLO CAB CON PLANA C/ARAN SCREW,WITH WASHER	4				
15	5TS-E443E-00	TUBO, DRENAJE PIPE, DRAIN	1				
16	90467-15012	PRESILLA CLIP	1				
17	5TS-E446R-00	SELLO SEAL	1				
18	5TS-E4415-00	SOPORTE DE CABLE HOLDER, WIRE	1				
19	5TS-E4459-00	SOPORTE DE GUIA HOLDER, GUIDE	1				
20	90119-06108	TORNILLO CON ARANDELA BOLT, WITH WASHER	2				
21	90387-066K1	ESPACIADOR COLLAR	2				
22	5UC-E4137-00	PRESILLA CLIP	1				

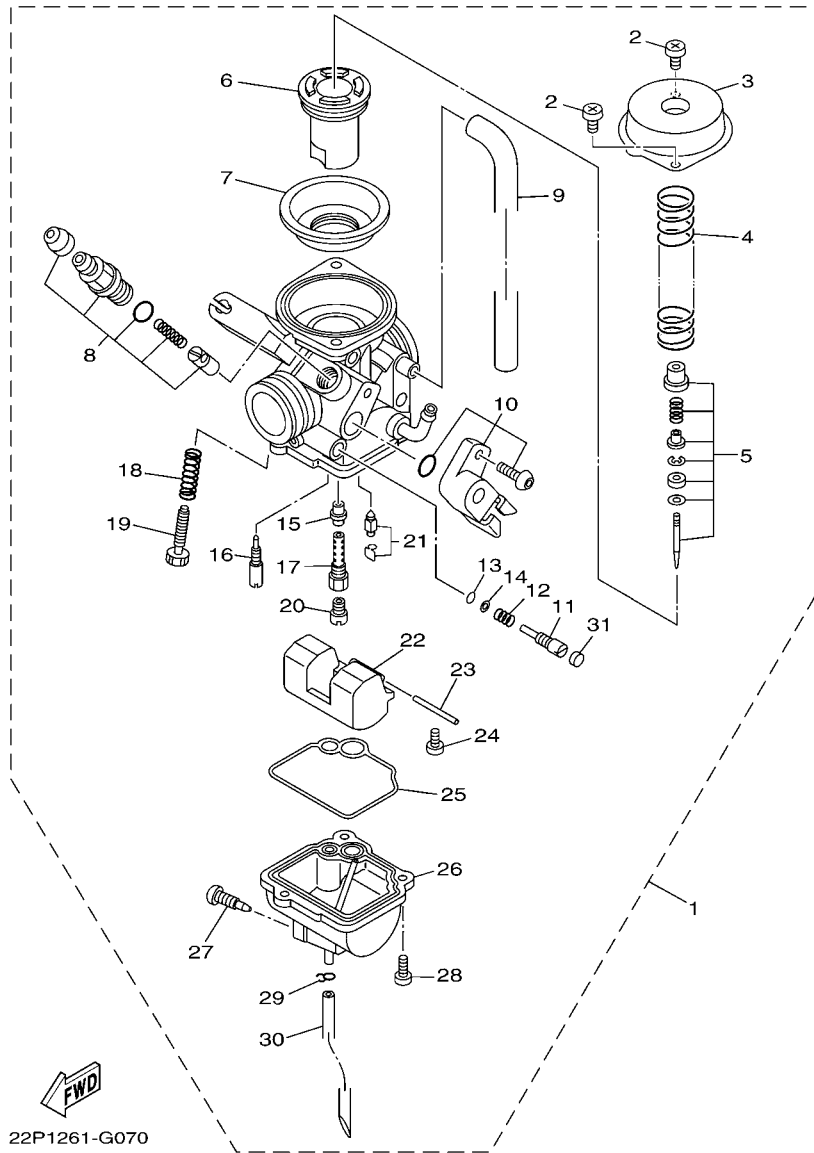

FIG. 7 CARBURADOR

CARBURETOR

REF. Nº	CODIGO Nº PART NO.	DESCRIPCION DESCRIPTION	22P2				OBSERVACIONES REMARKS
1	5YY-E4901-02	CARBURADOR COMPLETO 1 CARBURETOR ASSY 1	1				
2	98507-05008	.TORNILLO DE CABEZA CON PLANA .SCREW, PAN HEAD	2				
3	5LW-14958-00	.CUBIERTA DE DIAFRAGMA .COVER, DIAPHRAGM	1				
4	5LW-14589-00	.RESORTE .SPRING	1				
5	5YY-WE142-00	.MANIVELA SEMI-ARMADA 2 .NEEDLE SET KIT	1				
6	5YY-14192-00	.BANDEJA DE COMBUSTIBLE .PAN, FUEL	1				
7	5YY-24411-10	.DIAFRAGMA .DIAPHRAGM	1				
8	5YY-WE141-00	.MANIVELA SEMI-ARMADA 1 .STARTER SET KIT	1				
9	5YY-14197-00	.TUBO RESPIRADERO .PIPE	1				
10	5YY-WH585-00	.JUEGO DE ACELERADOR DE SENSORI .THROTTLE POSITION SENSOR KIT	1				
11	5YY-14923-20	.TORNILLO DE AJUSTE .SCREW, PILOT	1				
12	5K7-14134-00	.RESORTE AJUSTE DE VALVULA .SPRING, AIR ADJUSTING	1				
13	3H1-14147-00	.ANILLO O .O-RING	1				
14	3H1-14962-00	.ARANDELA .WASHER	1				
15	5LW-14141-00	.BOQUILLA PRINCIPAL .NOZZLE, MAIN	1				
16	5LW-14142-15	.SURTIDOR DE RALENTI (# 15) .JET, PILOT (# 15)	1				
17	5LW-14261-00	.SOSTEN .HOLDER	1				
18	4BH-14934-00	.RESORTE DE TOPE DE OBTURADOR .SPRING, THROTTLE STOP	1				
19	2LN-14122-00	.TORNILLO DE OBTURACION .SCREW, THROTTLE	1				
20	3G2-1423A-76	.INYECTOR, PRINCIPAL (#127.5) .JET, MAIN (#127.5)	1				
21	5YY-14390-00	.VALVULA DE AGUJA COMPLETA .NEEDLE VALVE ASSY	1				
22	5HK-14985-00	.BOIA .FLOAT	1				
23	353-14186-00	.PASADOR DE LA BOYA .PIN, FLOAT	1				
24	98507-04008	.TORNILLO DE CABEZA CON PLANA .SCREW, PAN HEAD	1				
25	5HK-14147-00	.ANILLO O .O-RING	1				
26	5YY-14981-00	.CUERPO CAMARA DE BOIA .BODY, FLOAT CHAMBER	1				
27	4TL-14191-00	.TORNILLO, DE DRENAJE .PLUG, DRAIN	1				

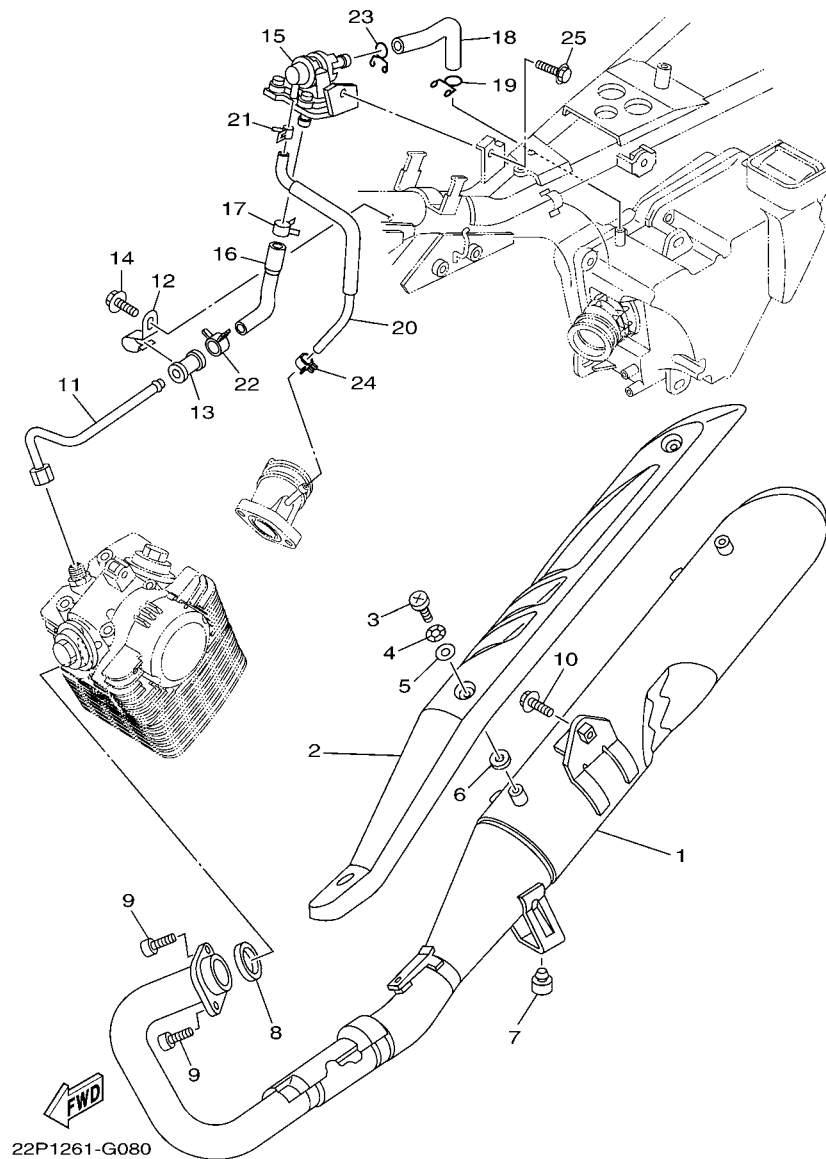

FIG. 8 DESCARGA

EXHAUST

REF. N°	CODIGO N° PART NO.	DESCRIPCION DESCRIPTION	22P2				OBSERVACIONES REMARKS
1	5YY-E4703-20	SILENCIADOR COMPL. 1 MUFFLER COMP. 1	1				
2	22P-E4758-00	PROTECTOR DE SILENCIADOR PROTECTOR, SILENCER	1				
3	98980-06012	TORNILLO DE LIGAR SCREW, BIND	5				
4	90206-06090	ARANDELA ONDULADA WASHER, WAVE	5				
5	90202-05807	ARANDELA DE PLANA WASHER, PLATE	5				
6	90201-05016	ARANDELA PLANA WASHER, PLATE	5				
7	22P-F4741-00	COJIN DE ASIENTO PAD, SEAT	1				
8	3AH-E4613-00	JUNTA, TUBO DE ESCAPE GASKET, EXHAUST PIPE	1				
9	91317-06020	PERNO BOLT	2				
10	95817-08025	TORNILLO BOLT, FLANGE	1				
11	5YY-E4872-00	TUBO 2 PIPE 2	1				
12	5YY-E4849-00	SOPORTE BRACKET	1				
13	5YY-E4844-00	AMORTIGUADOR DAMPER	1				
14	95807-06012	TORNILLO BOLT, FLANGE	1				
15	5YY-E4803-00	VALVULA DE AIRE COMPLETA AIR INDUCTION SYSTEM ASSY	1				
16	5YY-E4881-00	TUBO 1 HOSE, BEND 1	1				
17	90467-16805	PRESILLA CLIP	1				
18	5YY-E4882-00	TUBO 2 HOSE, BEND 2	1				
19	90467-16195	PRESILLA CLIP	1				
20	5YY-E4987-00	TUBO HOSE	1				
21	90467-08801	PRESILLA CLIP	1				
22	90467-13802	PRESILLA CLIP	1				
23	90467-16195	PRESILLA CLIP	1				
24	90467-08801	PRESILLA CLIP	1				
25	95807-06012	TORNILLO BOLT, FLANGE	1				

FIG. 10 CUBIERTA DE CARTER 1

CRANKCASE COVER 1

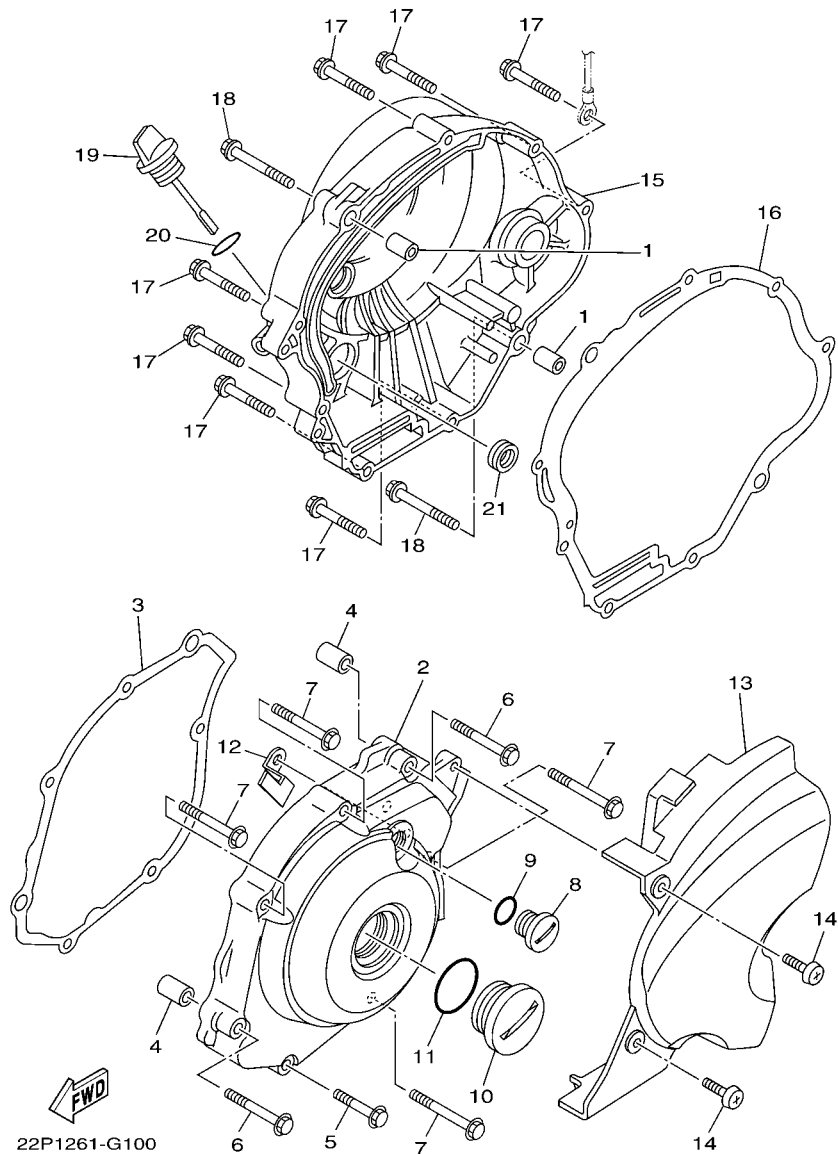

REF. Nº	CODIGO Nº PART NO.	DESCRIPCION DESCRIPTION	22P2				OBSERVACIONES REMARKS
1	91830-21014	PASADOR DE CLAVIJA PIN, DOWEL	2				
2	5YY-E5411-20	CUBIERTA DE CARTER 1 COVER, CRANKCASE 1	1				
3	5YY-E5451-00	EMPAQ DE CUBIERTA DE CARTER GASKET, CRANKCASE COVER 1	1				
4	91830-21014	PASADOR DE CLAVIJA PIN, DOWEL	2				
5	95027-06035	PERNO, DE BRIDA BOLT, FLANGE	1				
6	95027-06045	PERNO, DE BRIDA BOLT, FLANGE	2				
7	95027-06055	PERNO, DE BRIDA BOLT, FLANGE	4				
8	90340-14814	TORNILLO, DE DRENAJE PLUG, STRAIGHT SCREW	1				
9	93210-14899	ANILLO O O-RING	1				
10	90340-32808	TORNILLO, DE DRENAJE PLUG, STRAIGHT SCREW	1				
11	93210-328A4	ANILLO O O-RING	1				
12	5YY-E5191-00	PLACA PLATE	1				
13	5YY-E5418-00	CUBIERTA CAJA DE CADENA COVER, CHAIN CASE	1				
14	98907-06016	TORNILLO DE LIGAR SCREW, BIND	2				
15	5YY-E5421-10	TAPA DE CARTER DERECHA COVER, CRANKCASE 2	1				
16	5YY-E5461-01	JUNTA TAPA CARTER DERECHO 2 GASKET, CRANKCASE COVER 2	1				
17	95027-06035	PERNO, DE BRIDA BOLT, FLANGE	7				
18	95027-06045	PERNO, DE BRIDA BOLT, FLANGE	2				
19	4LS-E5362-00	TAPON DEL NIVEL DE ACEITE PLUG, OIL LEVEL	1				
20	93210-19809	ANILLO O O-RING	1				
21	93101-10838	SELLO ACEITE OIL SEAL	1				

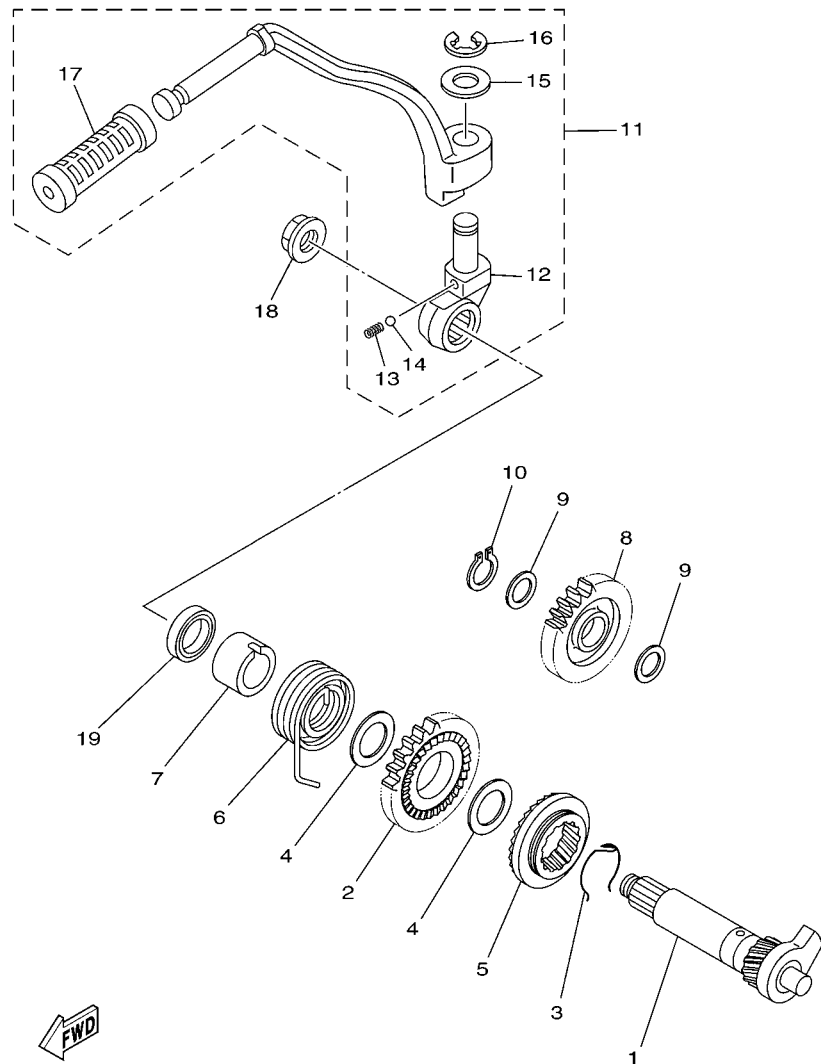

22P1261-G110

FIG. 11 ARRANQUE

STARTER

REF. Nº	CODIGO Nº PART NO.	DESCRIPCION DESCRIPTION	22P2				OBSERVACIONES REMARKS
1	5YY-E5661-00	EJE DE PEDAL DE ARRANQUE AXLE, KICK	1				
2	5YY-E5641-00	ENGRANAJE PEDAL ARRANQUE (28T) GEAR, KICK (28T)	1				
3	90468-26048	PRESILLA CLIP	1				
4	90201-202L3	ARANDELA DE PLACA(0.5T) WASHER, PLATE (0.5T)	2				
5	5YY-E5671-00	RUEDA DE TRINQUETE WHEEL, RATCHET	1				
6	90508-26667	RESORTE DE TORSION SPRING, TORSION	1				
7	5YY-E5666-00	SEPARADOR SPACER	1				
8	5RE-E5651-00	PINON LIBRE, PEDAL ARRANQUE GEAR, KICK IDLE	1				
9	90201-178D3	ARANDELA PLANA WASHER, PLATE	2				
10	99009-17400	PRESILLA REDONDA CIRCLIP	1				
11	5YY-E5620-10	PEDAL DE ARRANQUE COMPLETO KICK CRANK ASSY	1				
12	5DG-E5621-00	.COPA DE MANIVELA DE PEDAL .BOSS, KICK CRANK	1				
13	90501-12081	.RESORTE DE COMPRESION .SPRING, COMPRESSION	1				
14	93507-32819	.ESFERA .BALL	1				
15	90201-15809	.ARANDELA PLANA .WASHER, PLATE	1				
16	99001-10600	.PRESILLA REDONDA .CIRCLIP	1				
17	36L-E5618-00	.GOMA PROTECTORA, PEDAL .COVER, KICK LEVER	1				
18	90179-12800	TUERCA NUT	1				
19	93109-20821	SELLO ACEITE OIL SEAL	1				

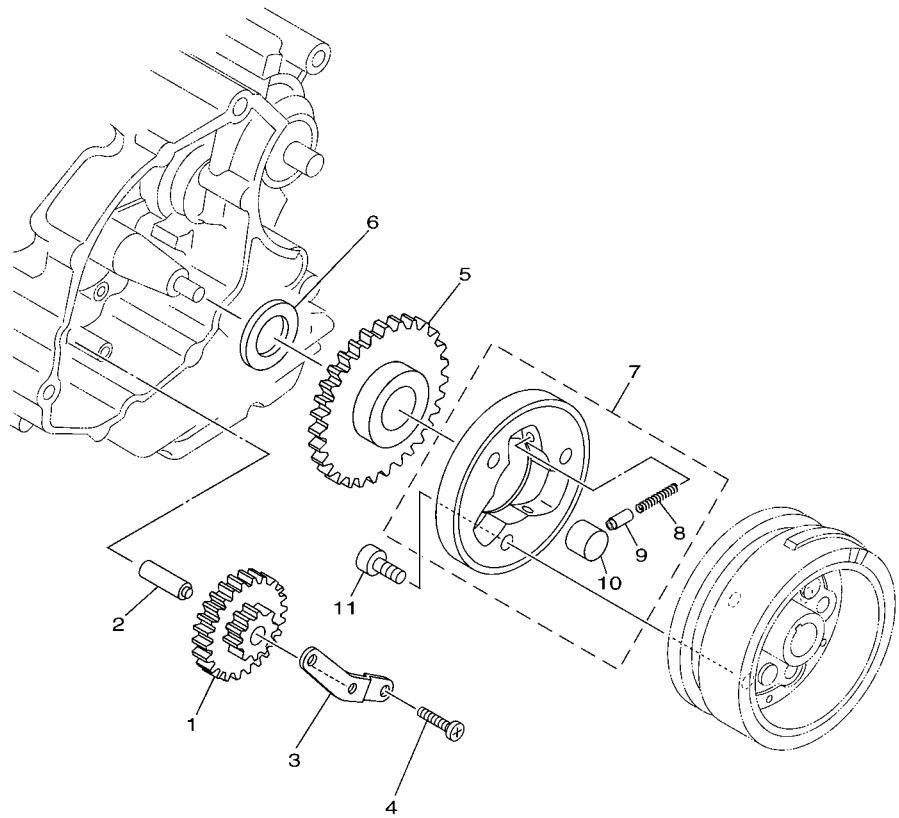

22P1261-G120

FIG. 12 EMBRAGUE DEL ARRANQUE STARTER CLUTCH

REF. Nº	CODIGO Nº PART NO.	DESCRIPCION DESCRIPTION	22P2				OBSERVACIONES REMARKS
1	5VL-E5512-00	ENGRENAJE NEUTRO GEAR, IDLER 1	1				
2	5US-E5521-00	EJE 1 SHAFT 1	1				
3	5US-E5532-00	PLACA DE ENGRENAGE NEUTRO PLATE, IDLE GEAR	1				
4	9850N-06012	TORNILLO DE CABEZA CON PLANA SCREW, PAN HEAD	2				
5	5VL-E5517-00	ENGRENAJE POSICION 2DA GEAR, IDLER 2	1				
6	90201-25290	ARANDELA PLANA WASHER, PLATE	1				
7	4FP-E5580-00	ENSAMBLE EXT.EMBRAGUE ARRANQUE STARTER CLUTCH OUTER ASSY	1				
8	90501-04833	.RESORTE DE COMPRESION .SPRING, COMPRESSION	3				
9	4FP-E5583-01	.TAPA RESORTE EMBRAG.ARRANQ. .CAP, STARTER CLUTCH SPRING	3				
10	93615-12840	.PASADOR DE CLAVIJA .PIN, DOWEL	3				
11	90110-08808	TORNILLO ALLEN BOLT, HEXAGON SOCKET HEAD	3				

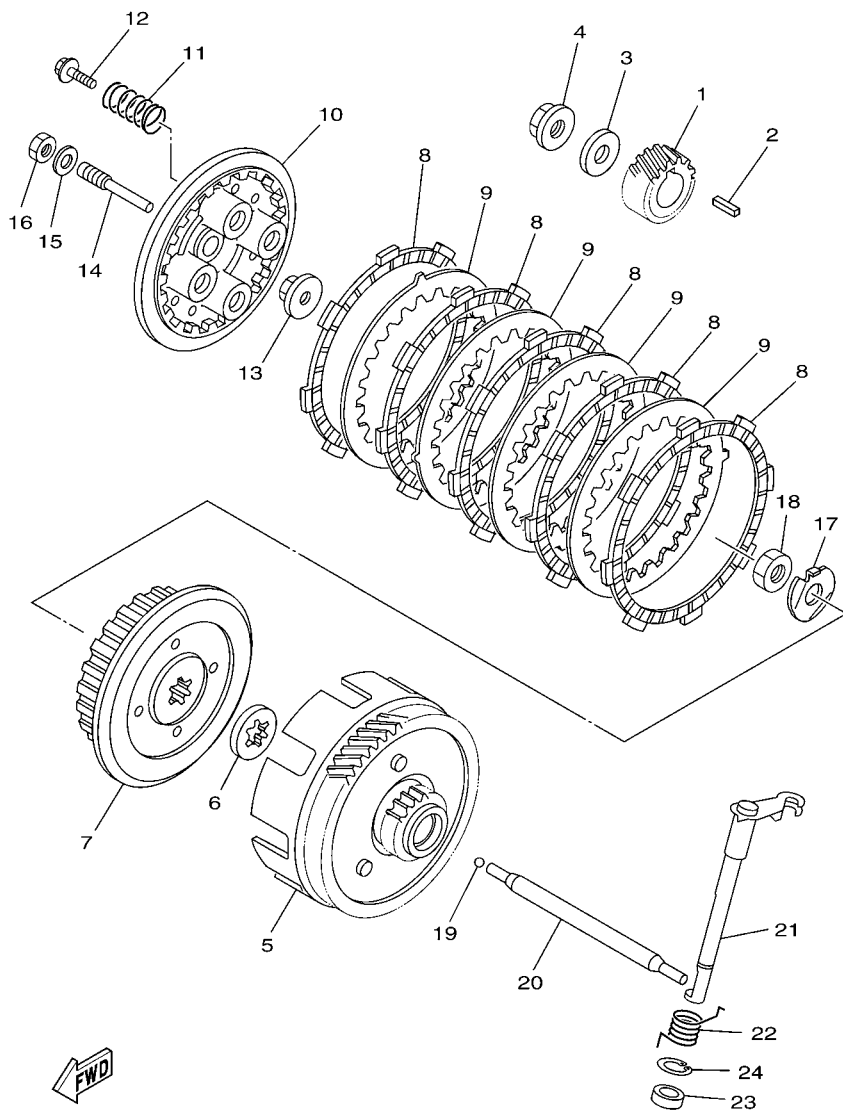

5P42200-F130

FIG. 13 EMBRAGUE

CLUTCH

REF. Nº	CODIGO Nº PART NO.	DESCRIPCION DESCRIPTION	22P2				OBSERVACIONES REMARKS
1	5RE-E6111-00	ENGRANAJE TRACC.PRIMARIA GEAR, PRIMARY DRIVE	1				
2	90282-05001	CHAVETA, RECTA (5MMX16MM) KEY, STRAIGHT (5MMX16MM)	1				
3	90201-122H1	ARANDELA PLANA WASHER, PLATE	1				
4	90179-12800	TUERCA NUT	1				
5	5YY-E6150-20	CAMPANA DE EMBRAGUE PRIMARY DRIVEN GEAR COMP.	1				
6	5YY-E6154-00	ARANDELA, DE EMPUJE 1 PLATE, THRUST 1	1				
7	5KA-E6371-10	CUBO, DE EMBRAGUE BOSS, CLUTCH	1				
8	5YY-E6321-00	PLACA DE FRICCION PLATE, FRICTION	5				
9	5RE-E6324-10	PLACA DE EMBRAGUE PLATE, CLUTCH 1	4				
10	5RE-E6351-00	PLATO DE PRESION PLATE, PRESSURE 1	1				
11	90501-216A6	RESORTE DE COMPRESION SPRING, COMPRESSION	4				
12	90119-05801	TORNILLO CON ARANDELA BOLT, WITH WASHER	4				
13	4LS-E6358-00	PLACA DE EMPUJE PLATE, PUSH	1				
14	4LS-E6356-00	VARILLA DE EMPUJE 1 ROD, PUSH 1	1				
15	9290N-06200	ARANDELA WASHER	1				
16	9530N-06600	TUERCA NUT	1				
17	90215-12815	ARANDELA DE CIERRE WASHER, LOCK	1				
18	90170-12060	TUERCA NUT	1				
19	93503-16807	ESFERA BALL	1				
20	4LS-E6357-00	VARILLA DE EMPUJE 2 ROD, PUSH 2	1				
21	4LS-E6381-00	CONJ. PALANCA DE EMPUJE PUSH LEVER COMP.	1				
22	90508-14857	RESORTE DE TORSION SPRING, TORSION	1				
23	93102-12877	SELLO ACEITE OIL SEAL	1				
24	99009-20500	PRESILLA REDONDA CIRCLIP	1				

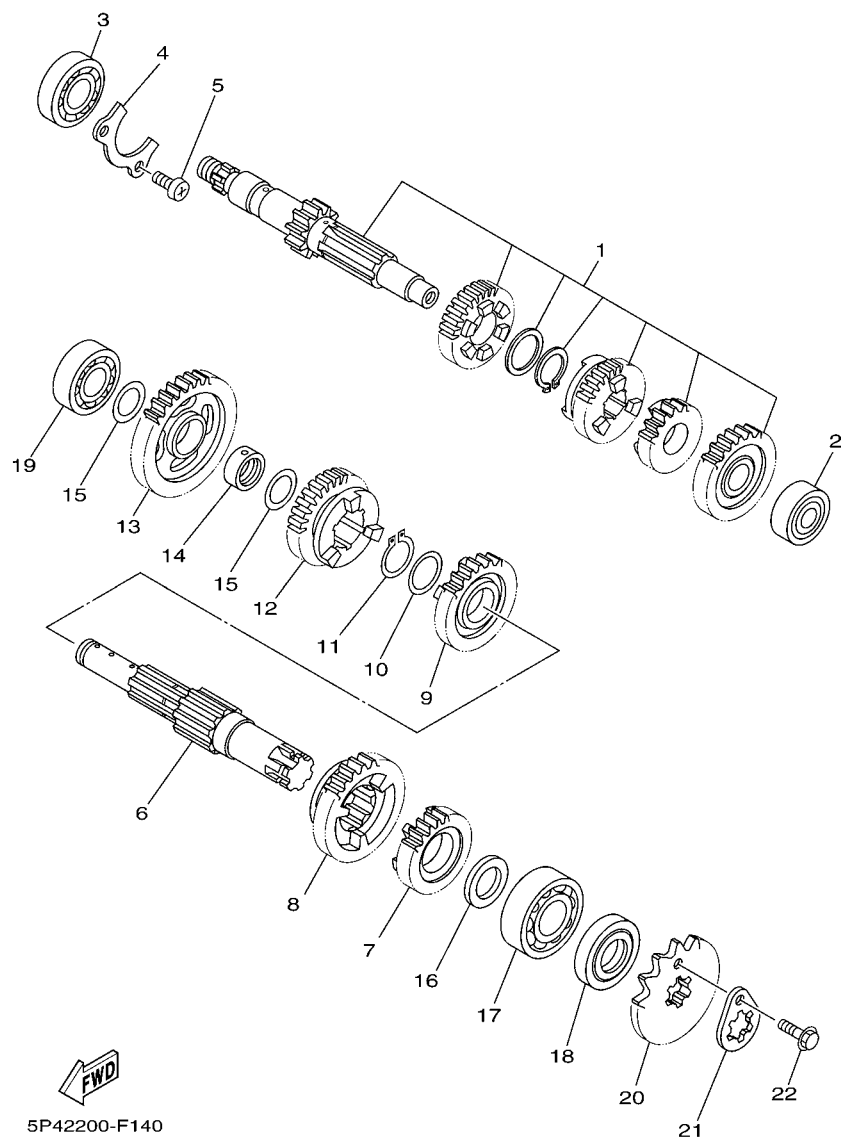

5P42200-F140

FIG. 14 TRANSMISION

TRANSMISION

REF. N°	CODIGO N° PART NO.	DESCRIPCION DESCRIPTION	22P2				OBSERVACIONES REMARKS
1	5YY-E7410-10	EJE PRINCIPAL COMPLETO MAIN AXLE COMP.	1				
2	93306-201Y4	COJINETE BEARING	1				
3	93306-203X2	COJINETE BEARING	1				
4	4LS-E7471-00	PLACA, DE CUBIERTA PLATE, COVER	1				
5	90157-06802	TORNILLO CABEZA CONICA PLANA SCREW, PAN HEAD	2				
6	5YY-E7402-10	EJE DE TRACCION COMPLETO DRIVE AXLE ASSY	1				
7	5YY-E7251-10	ENGRANAJE RUEDA DE 5TA (21T) GEAR, 5TH WHEEL (21T)	1				
8	5YY-E7221-10	ENGRANAJE RUEDA DE 2DA (32T) GEAR, 2ND WHEEL (32T)	1				
9	5YY-E7231-10	ENGRANAJE RUEDA DE 3RA (25T) GEAR, 3RD WHEEL (25T)	1				
10	90209-18208	ARANDELA DE SEPARACION WASHER	1				
11	93410-22039	SEGURO CIRCLIP	1				
12	5YY-E7241-10	ENGRANAJE DE RUEDA 4TA (23T) GEAR, 4TH WHEEL (23T)	1				
13	5YY-E7211-10	ENGRANAJE RUEDA DE 1 RA (33T) GEAR, 1ST WHEEL (33T)	1				
14	5YY-E7258-00	COLLAR 1 COLLAR 1	1				
15	90201-177G4	ARANDELA PLANA WASHER, PLATE	2				
16	90201-20272	ARANDELA PLANA WASHER, PLATE	1				
17	93306-204Y6	COJINETE BEARING	1				
18	93102-20876	SELLO ACEITE OIL SEAL	1				
19	93306-203X9	COJINETE BEARING	1				
20	93822-14800	CORONA (14T) SPROCKET, DRIVE (14T)	1				
21	4LS-E7456-00	SOPORTE DE CORONA HOLDER, SPROCKET	1				
22	95027-06010	PERNO, DE BRIDA BOLT, FLANGE	1				

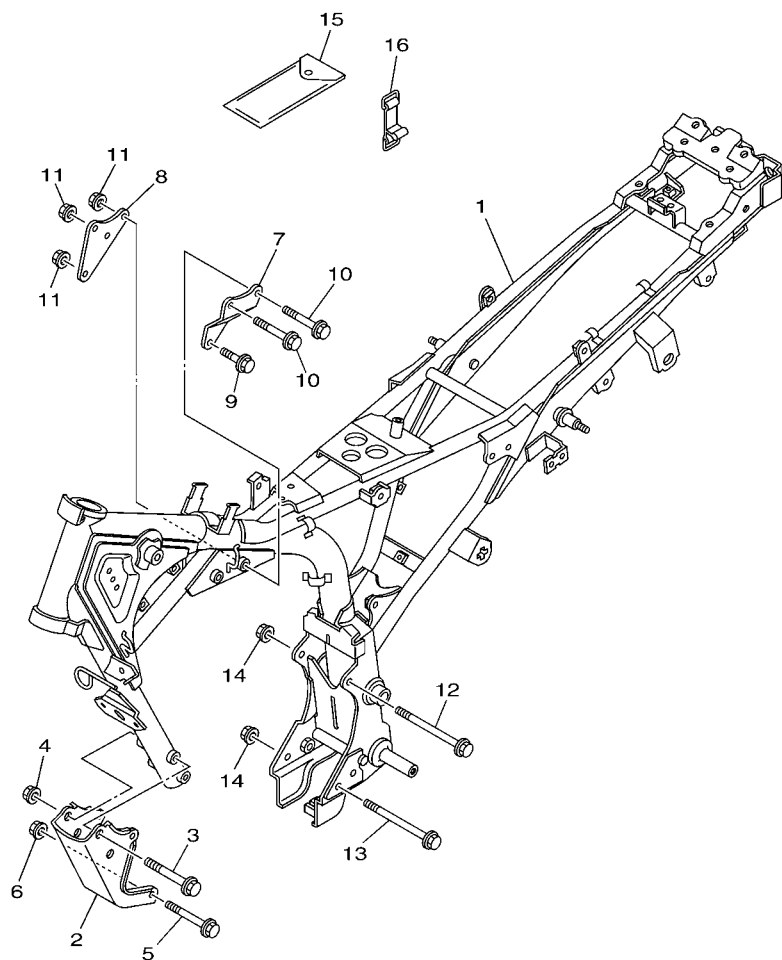

29C1261-F170

FIG. 17 CUADRO

FRAME

REF. N°	CODIGO N° PART NO.	DESCRIPCION DESCRIPTION	22P2				OBSERVACIONES REMARKS
1	22P-F1110-01	ARMAZON COMPLETO FRAME COMP.	1				
2	22P-F1316-00	SOPORTE DE MOTOR 3 STAY, ENGINE 3	1				
3	95817-10080	TORNILLO BOLT, FLANGE	2				
4	95707-10500	TUERCA DE BRIDA NUT, FLANGE	2				
5	90105-08201	TORNILLO BOLT, FLANGE	2				
6	95707-08500	TUERCA DE BRIDA NUT, FLANGE	2				
7	22P-F1317-00	SOPORTE DE MOTOR 3 STAY, ENGINE 3	1				
8	22P-F1318-00	SOPORTE DE MOTOR 5 STAY, ENGINE 5	1				
9	90105-08198	TORNILLO BOLT, FLANGE	1				
10	90105-08147	TORNILLO BOLT, FLANGE	2				
11	95702-08500	TUERCA DE REBORDE NUT, WITH WASHER	3				
12	90105-08007	TORNILLO BOLT, FLANGE	1				
13	90105-08202	TORNILLO BOLT, FLANGE	1				
14	95707-08500	TUERCA DE BRIDA NUT, FLANGE	2				
15	22P-F8100-00	JUEGO DE HERRAMIENTAS TOOL KIT	1				
16	5TS-F811G-00	CINTA BAND	1				

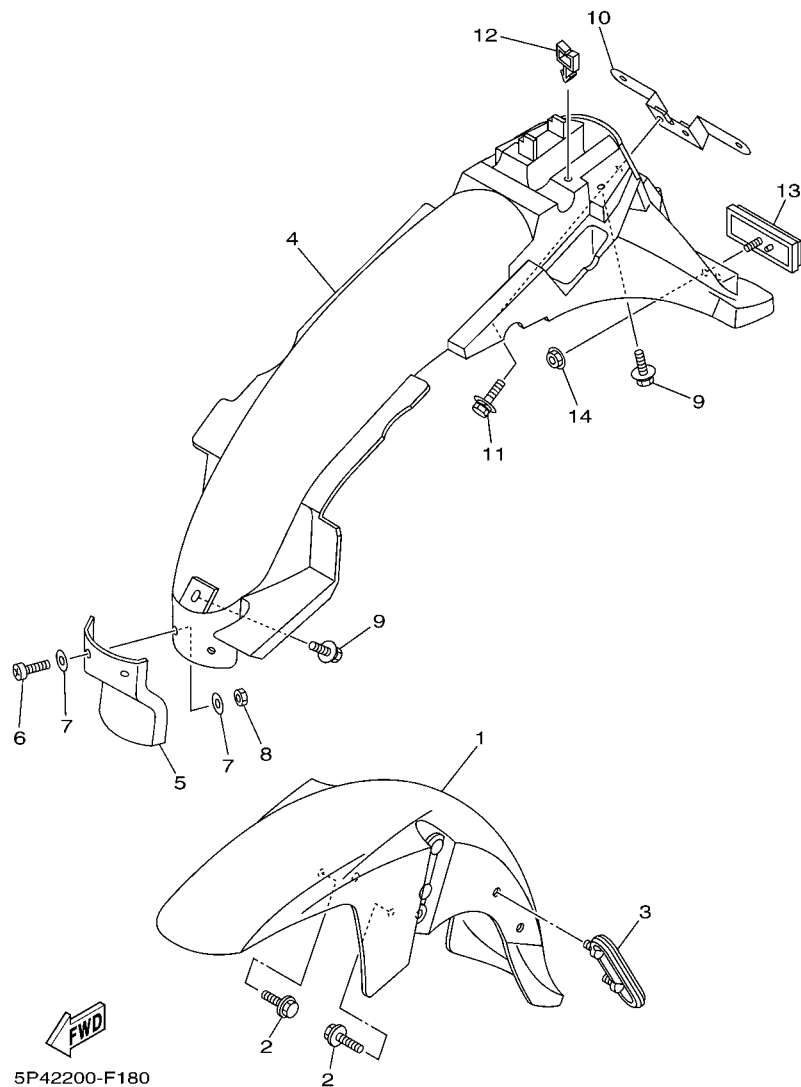

FIG. 18 GUARDABARRO

FENDER

REF. Nº	CODIGO Nº PART NO.	DESCRIPCION DESCRIPTION	22P2				OBSERVACIONES REMARKS
1	22P-F1510-00-0X	GUARDABARRO DELANTERO COMPLETO FRONT FENDER COMP.	1				UR PARA VRC1 UR FOR VRC1
	22P-F1510-00-1X	GUARDABARRO DELANTERO COMPLETO FRONT FENDER COMP.	1				UR PARA YB UR FOR YB
	22P-F1510-00-2X	GUARDABARRO DELANTERO COMPLETO FRONT FENDER COMP.	1				UR PARA HTS UR FOR HTS
	22P-F1510-00-3X	GUARDABARRO DELANTERO COMPLETO FRONT FENDER COMP.	1				UR PARA DPBMC UR FOR DPBMC
2	95822-06020	TORNILLO DE REBORDE BOLT, FLANGE	4				
3	5TS-F1518-00	SOPORTE DE CABLE HOLDER, CABLE	1				
4	5YY-F1611-00	GUARDABARRO TRASERO FENDER, REAR	1				
5	5YY-F1691-00	CHARNELA FLAP	1				
6	9850N-05012	TORNILLO DE CABEZA CON PLANA SCREW, PAN HEAD	2				
7	90201-05725	ARANDELA PLANA WASHER, PLATE	4				
8	9530N-05600	TUERCA NUT	2				
9	90119-06108	TORNILLO CON ARANDELA BOLT, WITH WASHER	3				
10	5C9-F1685-00	SOPORTE DE LICENCIA BRACKET, LICENSE	1				
11	90119-06108	TORNILLO CON ARANDELA BOLT, WITH WASHER	2				
12	90464-10829	BRIDA CLAMP	1				
13	5US-H5110-00	REFLECTOR COMPLETO REFLECTOR ASSY	1				
14	95707-05500	TUERCA DE BRIDA NUT, FLANGE	1				

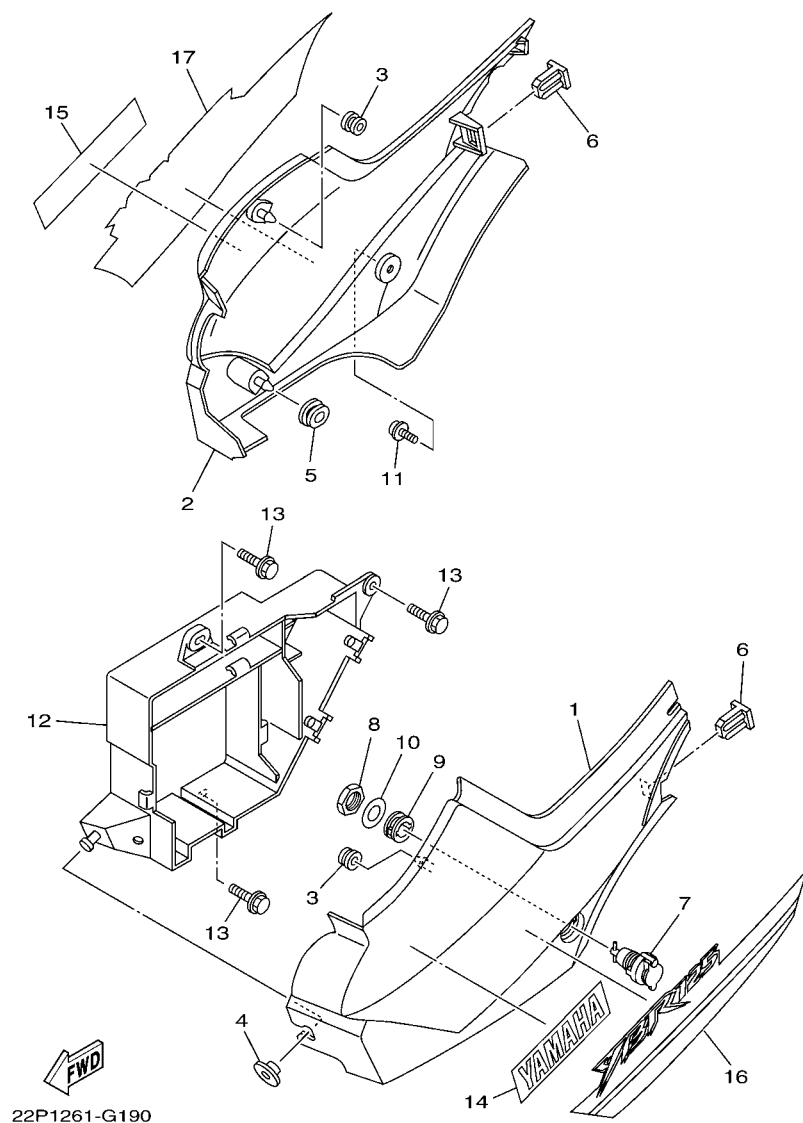
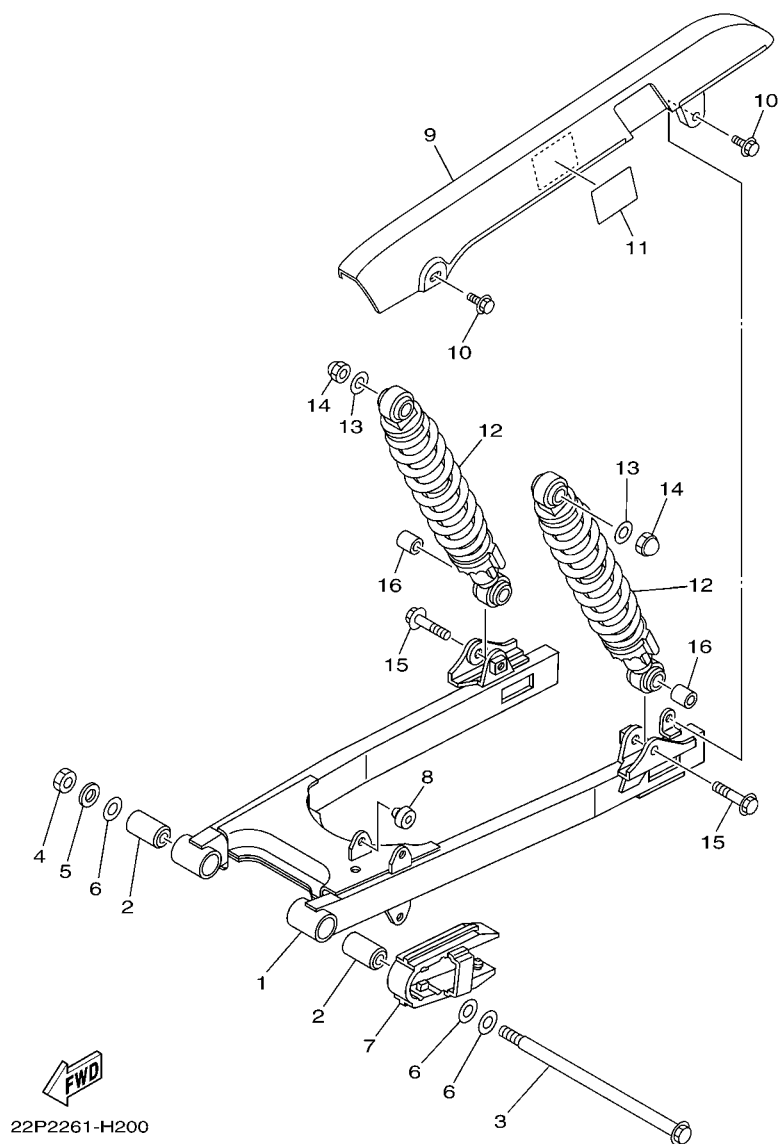

FIG. 19 CUBIERTA LATERAL

SIDE COVER

REF. Nº	CODIGO Nº PART NO.	DESCRIPCION DESCRIPTION	22P2			OBSERVACIONES REMARKS
1	22P-F1711-01-0X	CUBIERTA LATERAL 1 COVER, SIDE 1	1			YB EXCEPT PARA YB YB EXCEPT FOR YB
	22P-F1711-01-1X	CUBIERTA LATERAL 1 COVER, SIDE 1	1			VRC7 PARA YB VRC7 FOR YB
2	22P-F1721-00-0X	CUBIERTA LATERAL 2 COVER, SIDE 2	1			YB EXCEPT PARA YB YB EXCEPT FOR YB
	22P-F1721-00-1X	CUBIERTA LATERAL 2 COVER, SIDE 2	1			VRC7 PARA YB VRC7 FOR YB
3	90480-13426	TAPON GROMMET	2			
4	5YY-F1773-00	ANILLO PROTECTOR GROMMET	1			
5	5YY-F1773-10	ANILLO PROTECTOR GROMMET	1			
6	5YY-F1778-00	AMORTIGUADOR DE MONTAJE DAMPER, LOCATING 1	2			
7	2YA-F1780-00	CERRADURA COMPLETA LOCK ASSY	1			
8	90170-22187	TUERCA NUT	1			
9	90480-24186	TAPON GROMMET	1			
10	90201-225A4	ARANDELA PLANA (T=1.0) WASHER, PLATE (T=1.0)	1			
11	90159-06067	TORNILLO CON VALONA SCREW, WITH WASHER	1			
12	5YY-F177G-00	CAJA DE BATERIA BOX, BATTERY	1			
13	90119-06114	TORNILLO CON ARANDELA BOLT, WITH WASHER	3			
14	99246-00100	EMBLEMA, YAMAHA EMBLEM, YAMAHA	1			
15	99246-00100	EMBLEMA, YAMAHA EMBLEM, YAMAHA	1			
16	22P-F173E-00	GRAFICO 1 GRAPHIC 1	1			UR PARA VRC1 UR FOR VRC1
	22P-F173E-10	GRAFICO 1 GRAPHIC 1	1			UR PARA YB UR FOR YB
	22P-F173E-20	GRAFICO 1 GRAPHIC 1	1			UR PARA HTS UR FOR HTS
	22P-F173E-30	GRAFICO 1 GRAPHIC 1	1			UR PARA DPBMC UR FOR DPBMC
17	22P-F173F-00	GRAFICO 2 GRAPHIC 2	1			UR PARA VRC1 UR FOR VRC1
	22P-F173F-10	GRAFICO 2 GRAPHIC 2	1			UR PARA YB UR FOR YB
	22P-F173F-20	GRAFICO 2 GRAPHIC 2	1			UR PARA HTS UR FOR HTS
	22P-F173F-30	GRAFICO 2 GRAPHIC 2	1			UR PARA DPBMC UR FOR DPBMC

FIG. 20 BRAZO TRASERO & SUSPENSION REAR ARM & SUSPENSION



REF. Nº	CODIGO Nº PART NO.	DESCRIPCION DESCRIPTION	22P2				OBSERVACIONES REMARKS
1	22P-F2110-00	BRAZO TRASERO COMPLETO REAR ARM COMP.	1				
2	5TS-F2123-00	BUJE 1 BUSH 1	2				
3	5YY-F2141-00	EJE DEL BARCULANTE SHAFT, PIVOT	1				
4	95702-12500	TUERCA DE REBORDE NUT, WITH WASHER	1				
5	90201-122H1	ARANDELA PLANA WASHER, PLATE	1				
6	90201-14740	ARANDELA PLANA WASHER, PLATE	3				
7	5YY-F2151-00	SELLO DE GUARDA SEAL, GUARD	1				
8	4UU-F4724-00	AMORTIGUADOR DE ASIENTO DAMPER, SEAT	1				
9	22P-F2311-00	CABRECADENA CASE, CHAIN	1				
10	90119-06202	TORNILLO CON ARANDELA BOLT, WITH WASHER	2				
11	22P-F1668-00	ETIQUETA DE FRANJA LABEL, TIRE	1				
12	22P-F2210-00	AMORTIGUADOR TRASERO COMPLETO SHOCK ABSORBER ASSY, REAR	2				
13	90201-106F2	ARANDELA PLANA WASHER, PLATE	2				
14	90176-10073	TUERCA CORONA NUT, CROWN	2				
15	90105-10778	TORNILLO BOLT, FLANGE	2				
16	5YY-F2126-00	COLLAR DISTANCIADOR COLLAR, DISTANCE	2				

FIG. 21 DIRECCION

STEERING

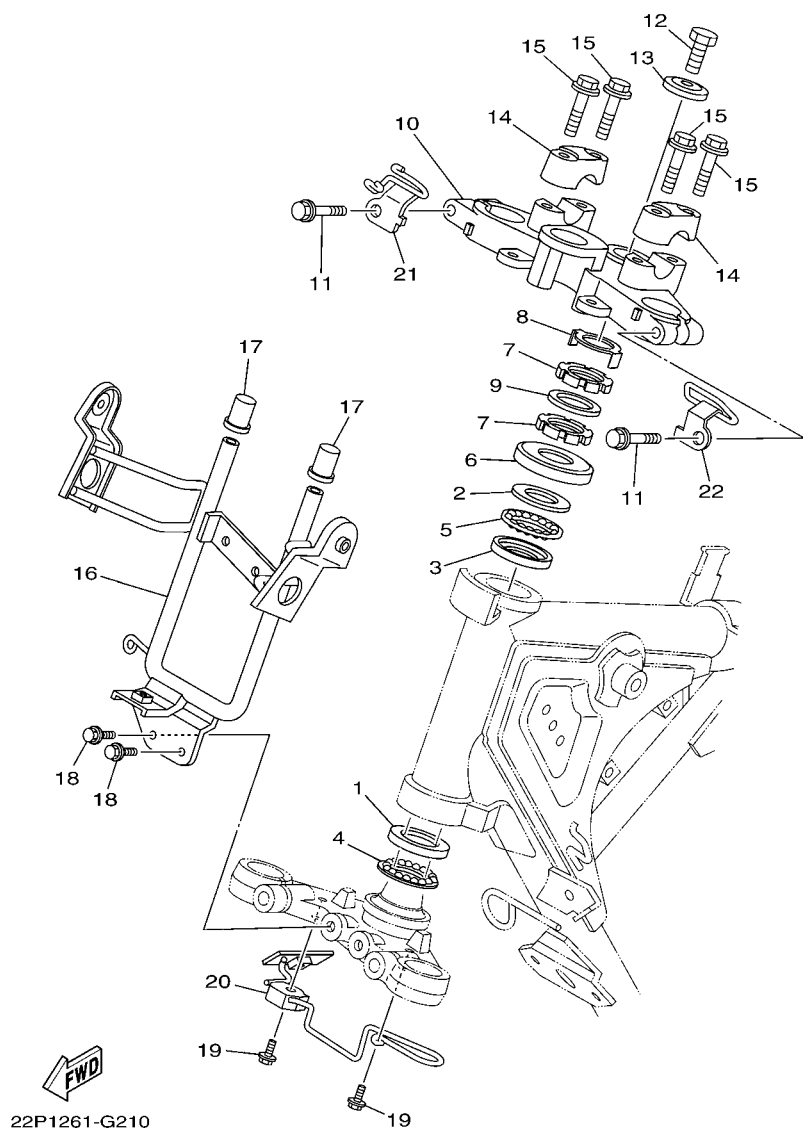

22P1261-G210

REF. Nº	CODIGO Nº PART NO.	DESCRIPCION DESCRIPTION	22P2				OBSERVACIONES REMARKS
1	5KA-F3412-00	PISTA DE BOLAS 2 RACE, BALL 2	1				
2	5KA-F3413-00	BASE DE BOLA 3 RACE, BALL 3	1				
3	5KA-F3414-00	BASE DE BOLA 4 RACE, BALL 4	1				
4	4LS-F341E-10	RETEN DE COJINETE RETAINER, BALL BEARING	1				
5	4LS-F341E-00	RETEN DE COJINETE RETAINER, BALL BEARING	1				
6	5YY-F3416-00	CUBIERTA DE BASE DE BOLA 2 COVER, BALL RACE 2	1				
7	90179-25033	TUERCA NUT	2				
8	4LS-F3418-00	ARANDELA ESPECIAL WASHER, SPECIAL	1				
9	90202-26142	ARANDELA DE PLANA WASHER, PLATE	1				
10	5YY-F3435-20	PLATINA SUPERIOR CROWN, HANDLE	1				
11	95827-08040	TORNILLO BOLT, FLANGE	2				
12	90105-10006	TORNILLO BOLT, FLANGE	1				
13	90209-10020	ARANDELA DE SEPARACION WASHER	1				
14	5TS-F3441-01	SOPORTE DE MANUBRIO HOLDER, HANDLE UPPER	2				
15	95027-08030	PERNO, DE BRIDA BOLT, FLANGE	4				
16	22P-F331A-00	APOYO STAY	1				
17	5YY-F317J-00	AMORTIGUADOR 1 DAMPER 1	2				
18	95827-06012	TORNILLO BOLT, FLANGE	2				
19	95827-06016	TORNILLO BOLT, FLANGE	2				
20	5YY-F3389-10	GUIA DE CABLE GUIDE, CABLE	1				
21	5YY-F6131-10	GUIA DE CABLE 1 GUIDE, CABLE 1	1				
22	5YY-F6132-00	GUIA DE CABLE 2 GUIDE, CABLE 2	1				

FIG. 22 HORQUILLA DELANTERA

FRONT FORK

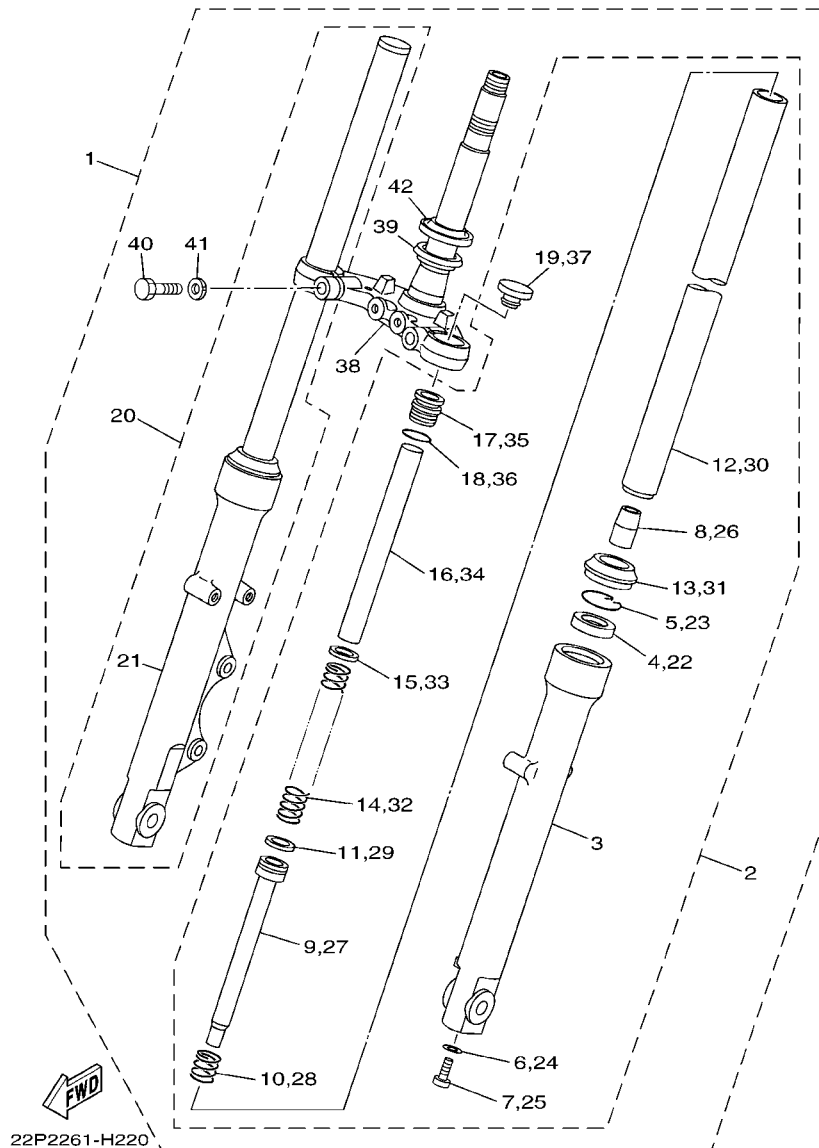

22P2261-H220

REF. Nº	CODIGO Nº PART NO.	DESCRIPCION DESCRIPTION	22P2				OBSERVACIONES REMARKS
1	5YY-F3100-33	HORQUILLA DELANTERA COMPLETA FRONT FORK ASSY	1				
2	5YY-F3102-33	HORQUILLA DELANTERA COMPL.(MI) FRONT FORK ASSY (L.H)	1				
3	5YY-F3106-10	.TUBO EXTERIOR COMPLETO (MI) .OUTER TUBE COMP. (L.H)	1				
4	5YY-F3145-10	.RETEN DE ACEITE .OIL SEAL	1				
5	4LS-F3153-00	.ANILLO DE ENGANCHE .RING, SNAP	1				
6	36L-F3158-00	.EMPAQUE .GASKET	1				
7	36L-F3181-00	.TORNILLO CABEZAHEXAGONAL .BOLT, HEXAGON SOCKET HEAD	1				
8	5US-F3173-00	.VASTAGO AHUSADO .SPINDLE, TAPER	1				
9	5YY-F3170-00	.CILINDRO COMPL. DE HORQ DELANT .CYLINDER COMP., FRONT FORK	1				
10	36L-F3152-10	.RESORTE DE SUBENSAMBLE .SPRING, SUB	1				
11	36L-F3157-00	.ANILLO DEL PISTON .RING, PISTON	1				
12	5YY-F3110-00	.TUBO INTERIOR COMPLETO 1 .INNER TUBE COMP.1	1				
13	5YY-F3144-10	.GUARDAPOLVO .SEAL, DUST	1				
14	5YY-F3141-10	.RESORTE HORQUILLA DELANT. .SPRING, FRONT FORK	1				
15	4LS-F3142-00	.ASIENTO DEL MUELLE SUPERIOR .SEAT, SPRING UPPER	1				
16	5YY-F3118-10	.SEPARADOR .SPACER	1				
17	36L-F3111-00	.TAPON .PLUG	1				
18	36L-F3147-00	.ARO .O-RING	1				
19	36L-F3168-00	.TAPA DE HORQUILLA DELANTERA .CAP, FRONT FORK	1				
20	5YY-F3103-33	HORQUILLA DELANTERA COMPL.(MD) FRONT FORK ASSY (R.H)	1				
21	5YY-F3107-10	.TUBO EXTERIOR COMPLETO (MD) .OUTER TUBE COMP. (R.H)	1				
22	5YY-F3145-10	.RETEN DE ACEITE .OIL SEAL	1				
23	4LS-F3153-00	.ANILLO DE ENGANCHE .RING, SNAP	1				
24	36L-F3158-00	.EMPAQUE .GASKET	1				
25	36L-F3181-00	.TORNILLO CABEZAHEXAGONAL .BOLT, HEXAGON SOCKET HEAD	1				
26	5US-F3173-00	.VASTAGO AHUSADO .SPINDLE, TAPER	1				
27	5YY-F3170-00	.CILINDRO COMPL. DE HORQ DELANT .CYLINDER COMP., FRONT FORK	1				

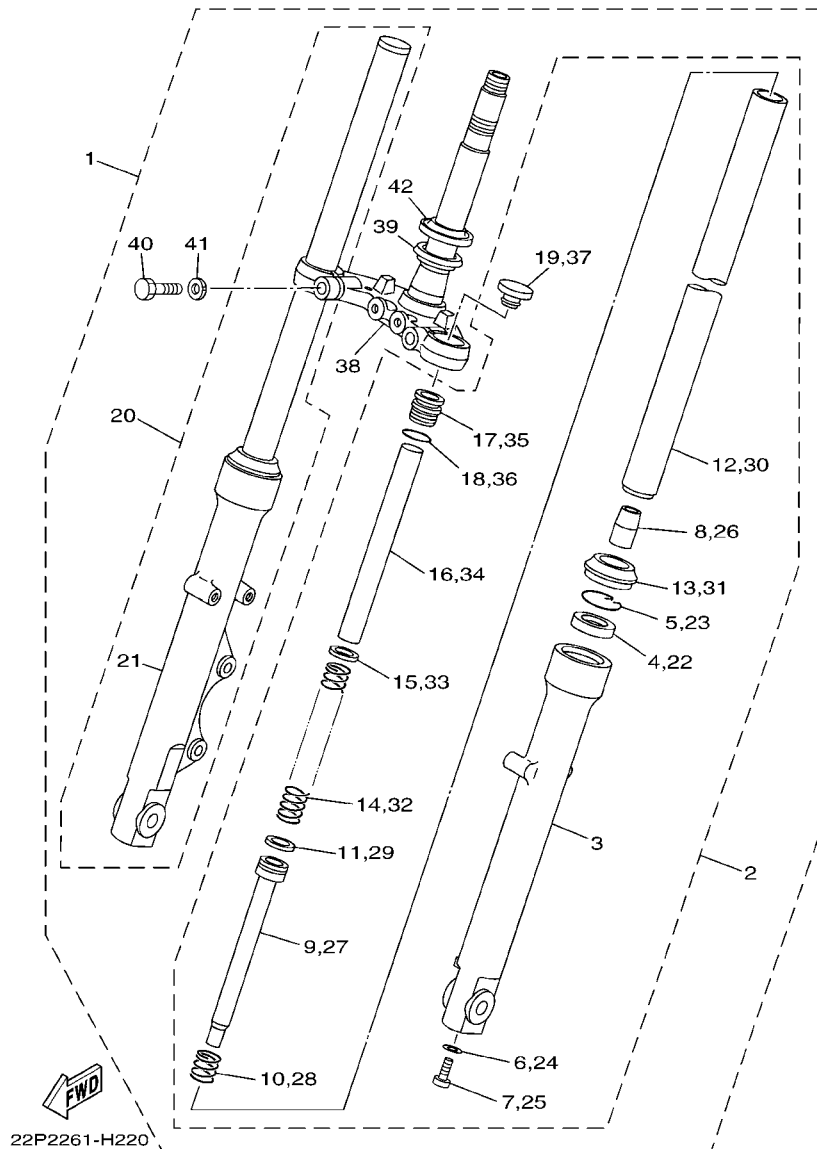
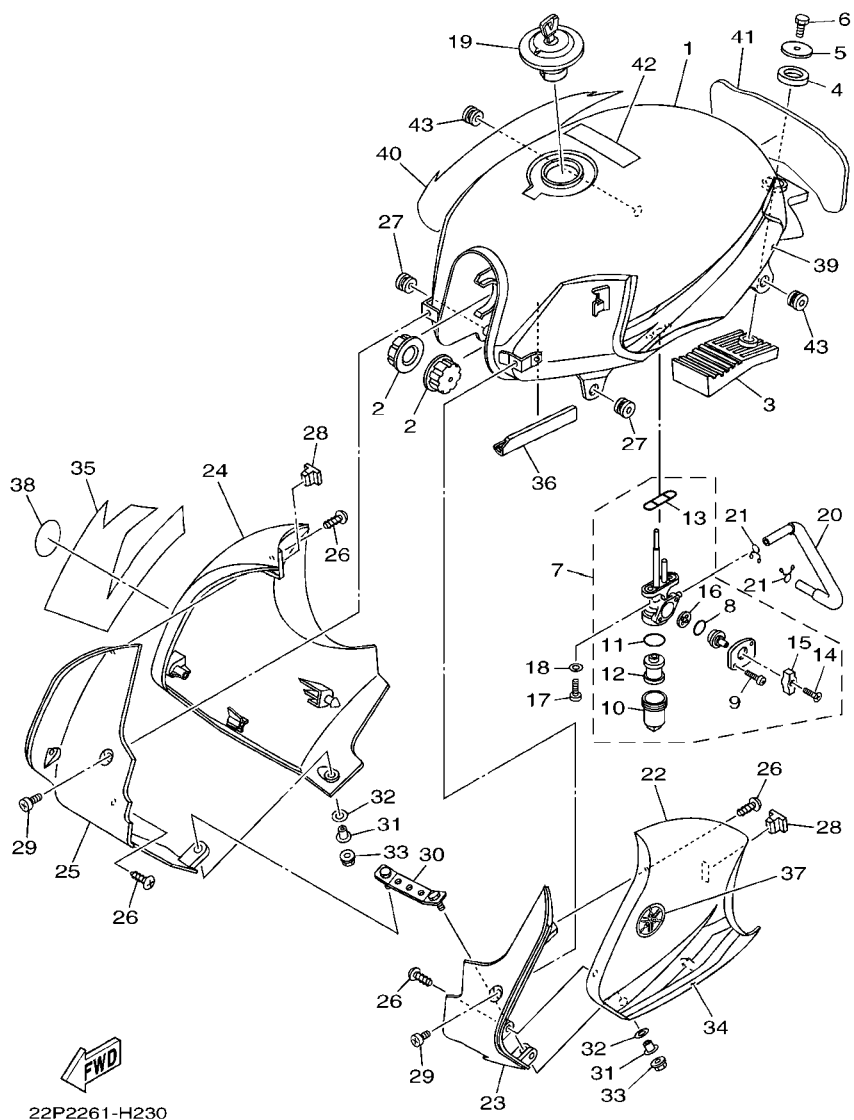

FIG. 22 HORQUILLA DELANTERA FRONT FORK

REF. Nº	CODIGO Nº PART NO.	DESCRIPCION DESCRIPTION	22P2				OBSERVACIONES REMARKS
28	36L-F3152-10	.RESORTE DE SUBENSAMBLE .SPRING, SUB	1				
29	36L-F3157-00	.ANILLO DEL PISTON .RING, PISTON	1				
30	5YY-F3110-00	.TUBO INTERIOR COMPLETO 1 .INNER TUBE COMP.1	1				
31	5YY-F3144-10	.GUARDAPOLVO .SEAL, DUST	1				
32	5YY-F3141-10	.RESORTE HORQUILLA DELANT. .SPRING, FRONT FORK	1				
33	4LS-F3142-00	.ASIENTO DEL MUELLE SUPERIOR .SEAT, SPRING UPPER	1				
34	5YY-F3118-10	.SEPARADOR .SPACER	1				
35	36L-F3111-00	.TAPON .PLUG	1				
36	36L-F3147-00	.ARO .O-RING	1				
37	36L-F3168-00	.TAPA DE HORQUILLA DELANTERA .CAP, FRONT FORK	1				
38	5YY-F3345-10	SOPORTE INFERIOR BRACKET, LOWER	1				
39	5YY-F3462-00	SELLO PARA POLVO SEAL, DUST	1				
40	36L-F3346-00	PERNO 1 BOLT 1	2				
41	36L-F3159-00	ARANDELA DE RESORTE INFERIOR WASHER, SPRING, LOWER	2				
42	5KA-F3411-00	PISTA DE BOLAS 1 RACE, BALL 1	1				

FIG. 23 DEPOSITO DE COMBUSTIBLE FUEL TANK



22P2261-H230

REF. Nº	CODIGO Nº PART NO.	DESCRIPCION DESCRIPTION	22P2			OBSERVACIONES REMARKS
1	22P-F4110-02-P0	DEPOSITO DE COMBUSTIBLE COMP. FUEL TANK COMP.	1			UR PARA VRC1 UR FOR VRC1
	22P-F4110-02-33	DEPOSITO DE COMBUSTIBLE COMP. FUEL TANK COMP.	1			UR PARA YB UR FOR YB
	22P-F4110-02-WG	DEPOSITO DE COMBUSTIBLE COMP. FUEL TANK COMP.	1			UR PARA HTS UR FOR HTS
	22P-F4110-02-P1	DEPOSITO DE COMBUSTIBLE COMP. FUEL TANK COMP.	1			UR PARA DPBMC UR FOR DPBMC
2	4UU-F4181-01	AMORTIGUADOR DE MONTAJE 1 DAMPER, LOCATING 1	2			
3	5YY-F4182-00	AMORTIGUADOR DE MONTAJE 2 DAMPER, LOCATING 2	1			
4	5US-F4183-00	AMORTIGUADOR DE MONTAJE 3 DAMPER, LOCATING 3	1			
5	90201-08569	ARANDELA PLANA WASHER, PLATE	1			
6	97027-08016	PERNO BOLT, HEXAGON	1			
7	4LS-F4500-02	GRIFO DE COMBUSTIBLE 1 FUEL COCK ASSY 1	1			
8	4UU-F4534-00	.SELLO DE GRIFO .SEAL, COCK	1			
9	98507-03008	.TORNILLO DE CABEZA PLANA .SCREW, PAN HEAD	2			
10	4UU-F4521-00	.COPA DE FILTRO .CUP, FILTER	1			
11	4UU-F4565-00	.EMPAQUE .GASKET	1			
12	4UU-F4515-00	.RED DE FILTRO 2 .NET, FILTER 2	1			
13	4UU-F4512-00	.EMPAQUE .O-RING	1			
14	90149-04242	.TORNILLO DE REGLAJE .SCREW	1			
15	4UU-F4524-00	.LLAVE DEL GRIFO .LEVER, COCK	1			
16	4UU-F4523-00	.VALVULA .VALVE	1			
17	90149-06108	TORNILLO DE REGLAJE SCREW	2			
18	90202-05193	ARANDELA DE PLANA WASHER, PLATE	2			
19	5TS-WF461-01	TAPA DE DEPOSITO COMPLETO CAP ASSY WITH LOCK	1			
20	5YY-F4311-00	TUBO DE COMBUSTIBLE 1 PIPE, FUEL 1	1			
21	90467-09006	PRESILLA CLIP	2			
22	22P-F137W-00-33	CUBIERTA DE GUIA DE AIRE 1 SCOOP, AIR 1	1			UR PARA YB UR FOR YB
	22P-F137W-00-P0	CUBIERTA DE GUIA DE AIRE 1 SCOOP, AIR 1	1			UR PARA VRC1 UR FOR VRC1
	22P-F137W-00-P1	CUBIERTA DE GUIA DE AIRE 1 SCOOP, AIR 1	1			UR PARA DPBMC UR FOR DPBMC

FIG. 23 DEPOSITO DE COMBUSTIBLE FUEL TANK

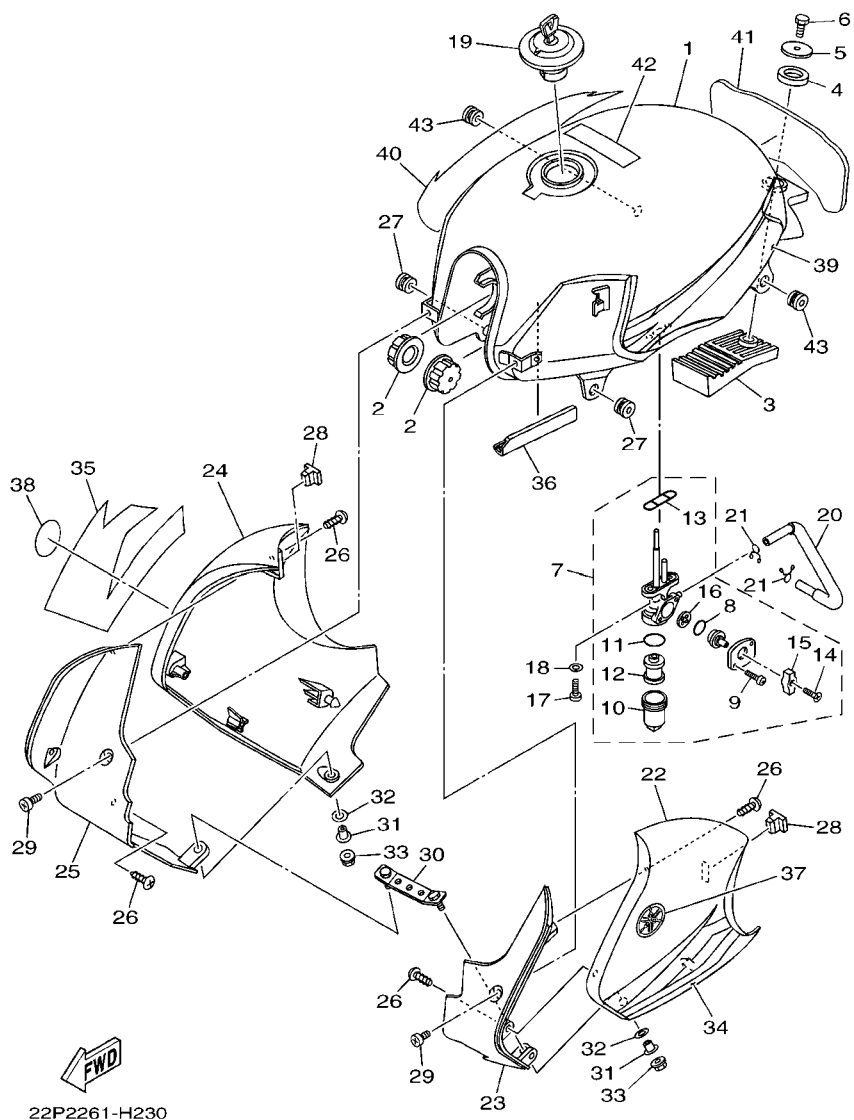

22P2261-H230

REF. Nº	CODIGO Nº PART NO.	DESCRIPCION DESCRIPTION	22P2			OBSERVACIONES REMARKS
22	22P-F137W-00-WG	CUBIERTA DE GUIA DE AIRE 1 SCOOP, AIR 1	1			UR PARA HTS UR FOR HTS
23	22P-F137U-00-33	GUIA DE AIRE 1 GUIDE, AIR 1	1			UR PARA YB UR FOR YB
	22P-F137U-00-P0	GUIA DE AIRE 1 GUIDE, AIR 1	1			UR PARA VRC1 UR FOR VRC1
	22P-F137U-00-P1	GUIA DE AIRE 1 GUIDE, AIR 1	1			UR PARA DPBMC UR FOR DPBMC
	22P-F137U-00-WG	GUIA DE AIRE 1 GUIDE, AIR 1	1			UR PARA HTS UR FOR HTS
24	22P-F137X-00-33	CUBIERTA DE GUIA DE AIRE 2 SCOOP, AIR 2	1			UR PARA YB UR FOR YB
	22P-F137X-00-P0	CUBIERTA DE GUIA DE AIRE 2 SCOOP, AIR 2	1			UR PARA VRC1 UR FOR VRC1
	22P-F137X-00-P1	CUBIERTA DE GUIA DE AIRE 2 SCOOP, AIR 2	1			UR PARA DPBMC UR FOR DPBMC
	22P-F137X-00-WG	CUBIERTA DE GUIA DE AIRE 2 SCOOP, AIR 2	1			UR PARA HTS UR FOR HTS
25	22P-F137V-00-33	GUIA DE AIRE 2 GUIDE, AIR 2	1			UR PARA YB UR FOR YB
	22P-F137V-00-P0	GUIA DE AIRE 2 GUIDE, AIR 2	1			UR PARA VRC1 UR FOR VRC1
	22P-F137V-00-P1	GUIA DE AIRE 2 GUIDE, AIR 2	1			UR PARA DPBMC UR FOR DPBMC
	22P-F137V-00-WG	GUIA DE AIRE 2 GUIDE, AIR 2	1			UR PARA HTS UR FOR HTS
26	90160-05807	TORNILLO REDONDO ROSCA HEMBRA SCREW, ROUND TAPPING	6			
27	90480-13426	TAPON GROMMET	2			
28	5TS-F1778-00	AMORTIGUADOR DE MONTAJE DAMPER, LOCATING 1	2			
29	98907-06010	TORNILLO DE LIGAR SCREW, BIND	2			
30	5YY-F4216-20	SOPORTE STAY	1			
31	90387-061N6	ESPACIADOR COLLAR	2			
32	90202-09800	ARANDELA DE PLANA WASHER, PLATE	2			
33	95707-06500	TUERCA DE BRIDA NUT, FLANGE	2			
34	22P-F137N-00	GRAFICO 1 GRAPHIC 1	1			UR PARA VRC1 UR FOR VRC1
	22P-F137N-10	GRAFICO 1 GRAPHIC 1	1			UR PARA YB UR FOR YB
	22P-F137N-20	GRAFICO 1 GRAPHIC 1	1			UR PARA HTS UR FOR HTS
	22P-F137N-30	GRAFICO 1 GRAPHIC 1	1			UR PARA DPBMC UR FOR DPBMC
35	22P-F137P-00	GRAFICO 2 GRAPHIC 2	1			UR PARA VRC1 UR FOR VRC1
	22P-F137P-10	GRAFICO 2 GRAPHIC 2	1			UR PARA YB UR FOR YB

FIG. 23 DEPOSITO DE COMBUSTIBLE FUEL TANK

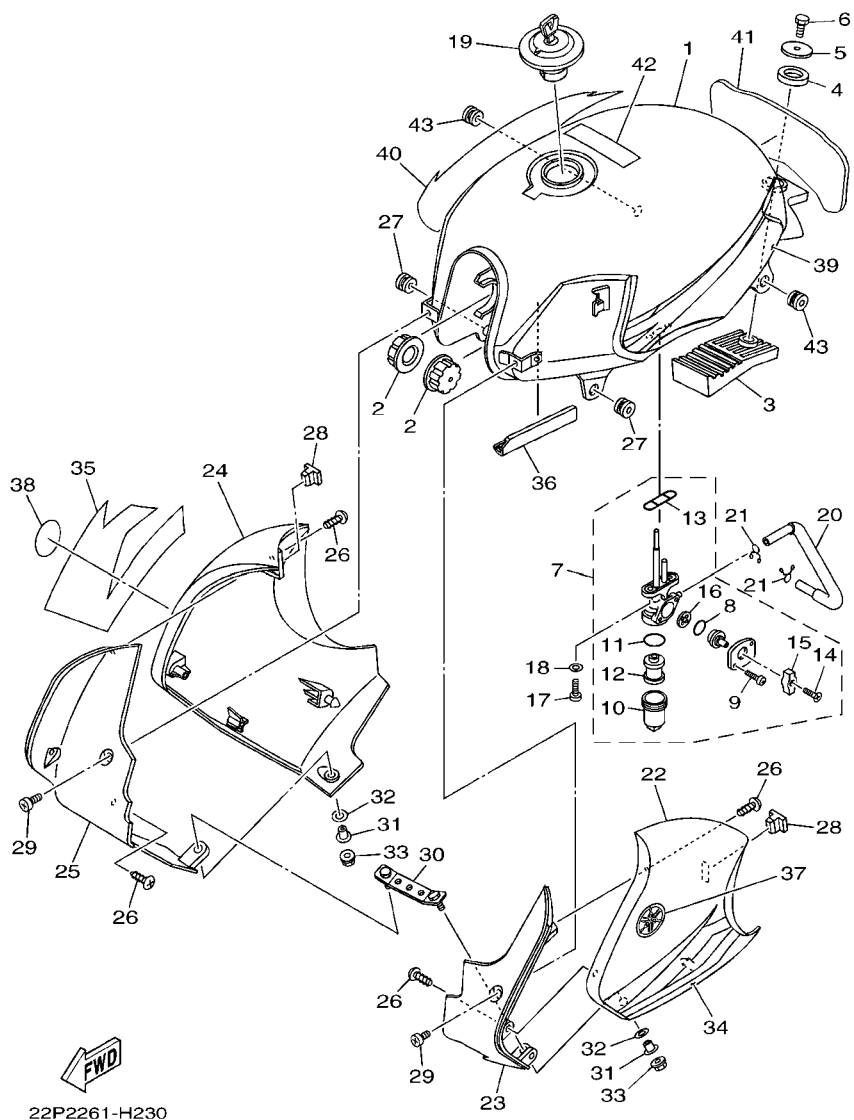

22P2261-H230

REF. Nº	CODIGO Nº PART NO.	DESCRIPCION DESCRIPTION	22P2				OBSERVACIONES REMARKS
35	22P-F137P-20	GRAFICO 2 GRAPHIC 2	1				UR PARA HTS UR FOR HTS
	22P-F137P-30	GRAFICO 2 GRAPHIC 2	1				UR PARA DPBMC UR FOR DPBMC
36	35B-F4188-00	MOLDURA DEPOSITO COMBUST. MOLD, FUEL TANK	1				
37	22P-F413B-00	EMBLEMA EMBLEM	1				
38	22P-F413B-00	EMBLEMA EMBLEM	1				
39	22P-F4244-00	CALCOMANIA DEPOSITO COMBUST.1 GRAPHIC, FUEL TANK 1	1				UR PARA VRC1 UR FOR VRC1
	22P-F4244-10	CALCOMANIA DEPOSITO COMBUST.1 GRAPHIC, FUEL TANK 1	1				UR PARA YB UR FOR YB
	22P-F4244-20	CALCOMANIA DEPOSITO COMBUST.1 GRAPHIC, FUEL TANK 1	1				UR PARA HTS UR FOR HTS
	22P-F4244-30	CALCOMANIA DEPOSITO COMBUST.1 GRAPHIC, FUEL TANK 1	1				UR PARA DPBMC UR FOR DPBMC
40	22P-F4245-00	CALCOMANIA DEPOSITO COMBUST.2 GRAPHIC, FUEL TANK 2	1				UR PARA VRC1 UR FOR VRC1
	22P-F4245-10	CALCOMANIA DEPOSITO COMBUST.2 GRAPHIC, FUEL TANK 2	1				UR PARA YB UR FOR YB
	22P-F4245-20	CALCOMANIA DEPOSITO COMBUST.2 GRAPHIC, FUEL TANK 2	1				UR PARA HTS UR FOR HTS
	22P-F4245-30	CALCOMANIA DEPOSITO COMBUST.2 GRAPHIC, FUEL TANK 2	1				UR PARA DPBMC UR FOR DPBMC
41	5YY-F4141-00	PROTECTOR DEPOSITO COMBUST. PROTECTOR, FUEL TANK	1				
42	5C9-F1568-S0	ETIQUETA DE PRECAUCION LABEL, WARNING	1				
43	90480-13861	TAPON GROMMET	4				

FIG. 24 ASIENTO

SEAT

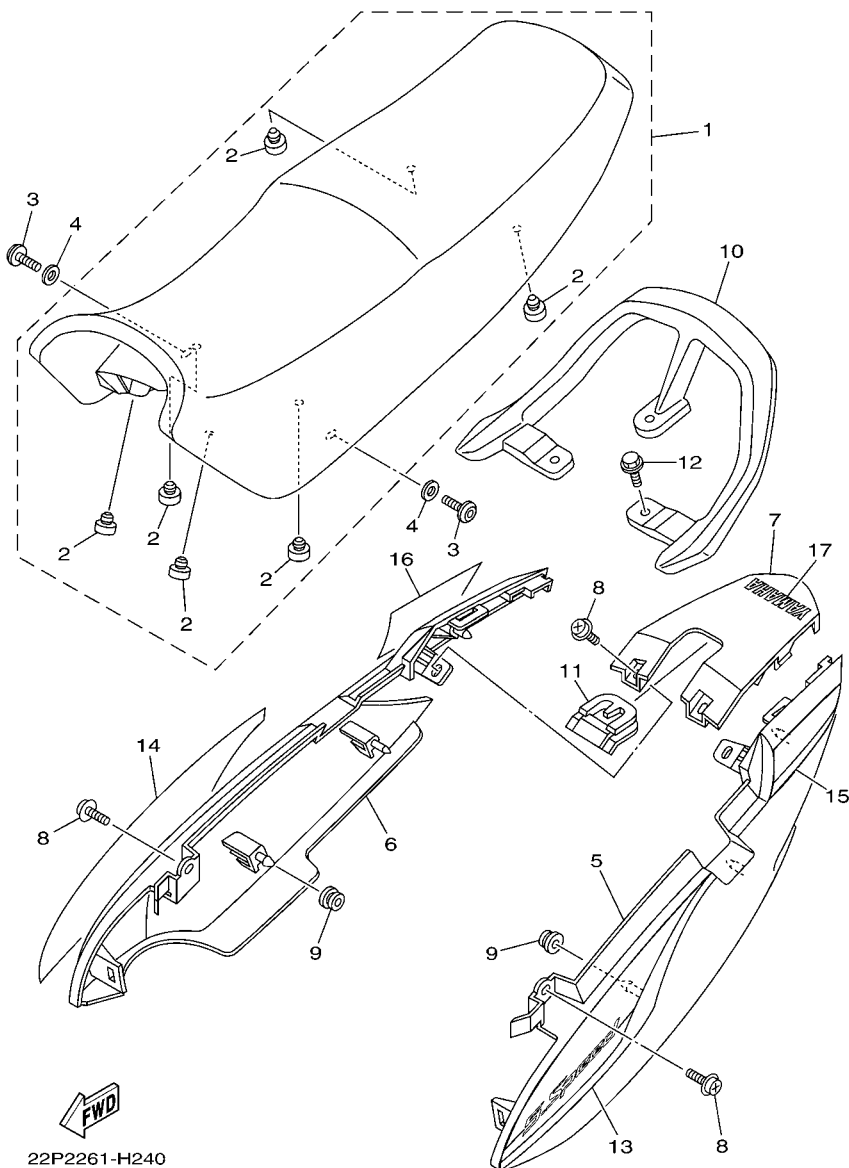

REF. Nº	CODIGO Nº PART NO.	DESCRIPCION DESCRIPTION	22P2				OBSERVACIONES REMARKS
1	22P-F4730-00	SILLIN DOBLE COMPLETO DOUBLE SEAT ASSY	1				
2	22P-F4741-00	.COJIN DE ASIENTO .PAD, SEAT	6				
3	92017-06014	PERNO BOLT, BUTTON HEAD	2				
4	90201-06057	ARANDELA PLANA WASHER, PLATE	2				
5	22P-F471K-01-P0	CUBIERTA, DE COLA 1 COVER, TAIL 1	1				UR PARA VRC1 UR FOR VRC1
	22P-F471K-01-33	CUBIERTA, DE COLA 1 COVER, TAIL 1	1				UR PARA YB UR FOR YB
	22P-F471K-01-WG	CUBIERTA, DE COLA 1 COVER, TAIL 1	1				UR PARA HTS UR FOR HTS
	22P-F471K-01-P1	CUBIERTA, DE COLA 1 COVER, TAIL 1	1				UR PARA DPBMC UR FOR DPBMC
6	22P-F472K-01-P0	CUBIERTA, DE COLA 2 COVER, TAIL 2	1				UR PARA VRC1 UR FOR VRC1
	22P-F472K-01-33	CUBIERTA, DE COLA 2 COVER, TAIL 2	1				UR PARA YB UR FOR YB
	22P-F472K-01-WG	CUBIERTA, DE COLA 2 COVER, TAIL 2	1				UR PARA HTS UR FOR HTS
	22P-F472K-01-P1	CUBIERTA, DE COLA 2 COVER, TAIL 2	1				UR PARA DPBMC UR FOR DPBMC
7	22P-F4756-00-P0	CUBIERTA DE COLA COVER, TAIL	1				UR PARA VRC1 UR FOR VRC1
	22P-F4756-00-33	CUBIERTA DE COLA COVER, TAIL	1				UR PARA YB UR FOR YB
	22P-F4756-00-WG	CUBIERTA DE COLA COVER, TAIL	1				UR PARA HTS UR FOR HTS
	22P-F4756-00-P1	CUBIERTA DE COLA COVER, TAIL	1				UR PARA DPBMC UR FOR DPBMC
8	90159-06067	TORNILLO CON VALONA SCREW, WITH WASHER	4				
9	90480-01870	TAPON GROMMET	2				
10	5YY-F4773-10-P0	MANIJA DE ASIENTO HANDLE, SEAT	1				
11	5YY-F4796-11	CUBIERTA COVER	1				
	95817-08020	TORNILLO BOLT, FLANGE	3				
13	22P-F477V-00	GRAFICO1 GRAPHIC 1	1				UR PARA VRC1 UR FOR VRC1
	22P-F477V-10	GRAFICO1 GRAPHIC 1	1				UR UR FOR YB
	22P-F477V-20	GRAFICO1 GRAPHIC 1	1				UR PARA HTS UR FOR HTS
	22P-F477V-30	GRAFICO1 GRAPHIC 1	1				UR PARA DPBMC UR FOR DPBMC
14	22P-F477W-00	GRAFICO 2 GRAPHIC 2	1				UR PARA VRC1 UR FOR VRC1
	22P-F477W-10	GRAFICO 2 GRAPHIC 2	1				UR PARA YB UR FOR YB

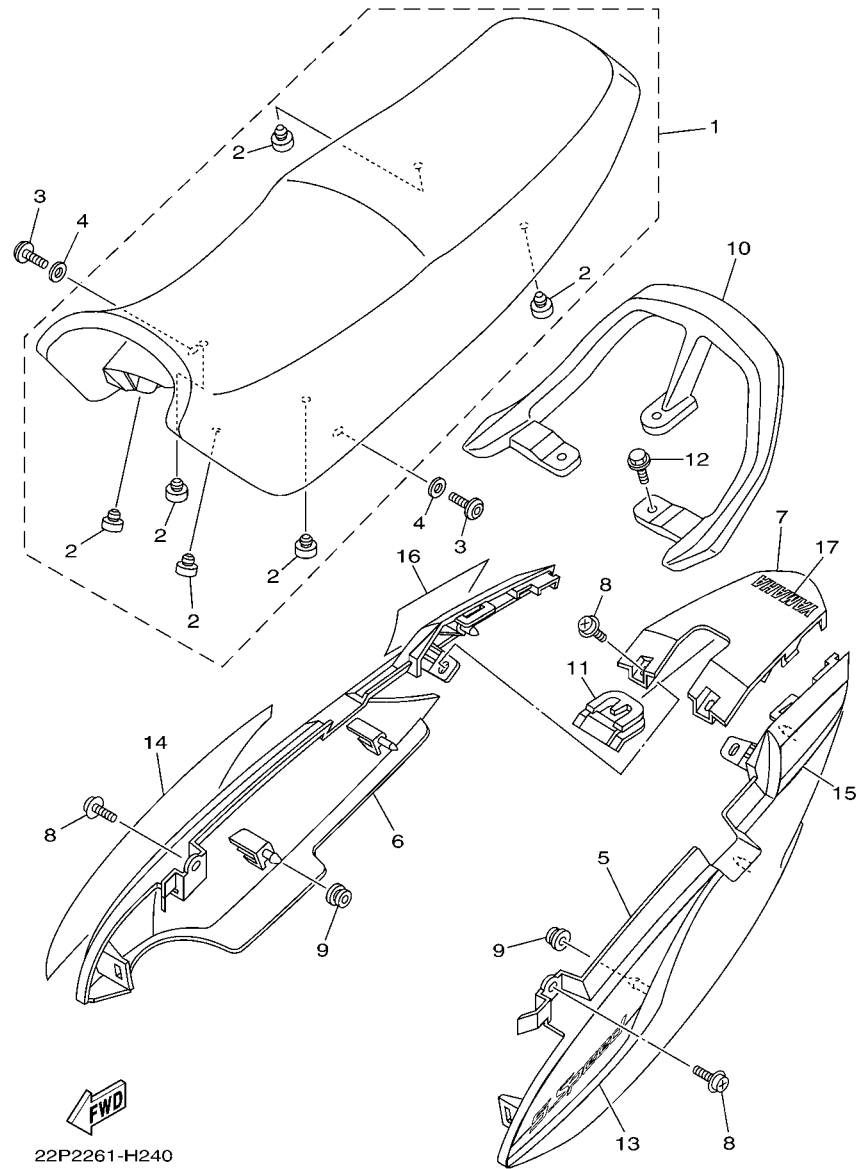

FIG. 24 ASIENTO

SEAT

REF. Nº	CODIGO Nº PART NO.	DESCRIPCION DESCRIPTION	22P2				OBSERVACIONES REMARKS
14	22P-F477W-20	GRAFICO 2 GRAPHIC 2	1				UR PARA HTS UR FOR HTS
	22P-F477W-30	GRAFICO 2 GRAPHIC 2	1				UR PARA DPBMC UR FOR DPBMC
15	22P-F477X-00	GRAFICO 3 GRAPHIC 3	1				UR PARA VRC1 UR FOR VRC1
	22P-F477X-10	GRAFICO 3 GRAPHIC 3	1				UR PARA YB UR FOR YB
	22P-F477X-20	GRAFICO 3 GRAPHIC 3	1				UR PARA HTS UR FOR HTS
	22P-F477X-30	GRAFICO 3 GRAPHIC 3	1				UR PARA DPBMC UR FOR DPBMC
16	22P-F477Y-00	GRAFICO 4 GRAPHIC 4	1				UR PARA VRC1 UR FOR VRC1
	22P-F477Y-10	GRAFICO 4 GRAPHIC 4	1				UR PARA YB UR FOR YB
	22P-F477Y-20	GRAFICO 4 GRAPHIC 4	1				UR PARA HTS UR FOR HTS
	22P-F477Y-30	GRAFICO 4 GRAPHIC 4	1				UR PARA DPBMC UR FOR DPBMC
17	99246-00080	EMBLEMA, YAMAHA EMBLEM, YAMAHA	1				EXCEPT PARA HTS EXCEPT FOR HTS
	99244-00080	EMBLEMA, YAMAHA EMBLEM, YAMAHA	1				PARA HTS FOR HTS

FIG. 25 RUEDA DELANTERA

FRONT WHEEL

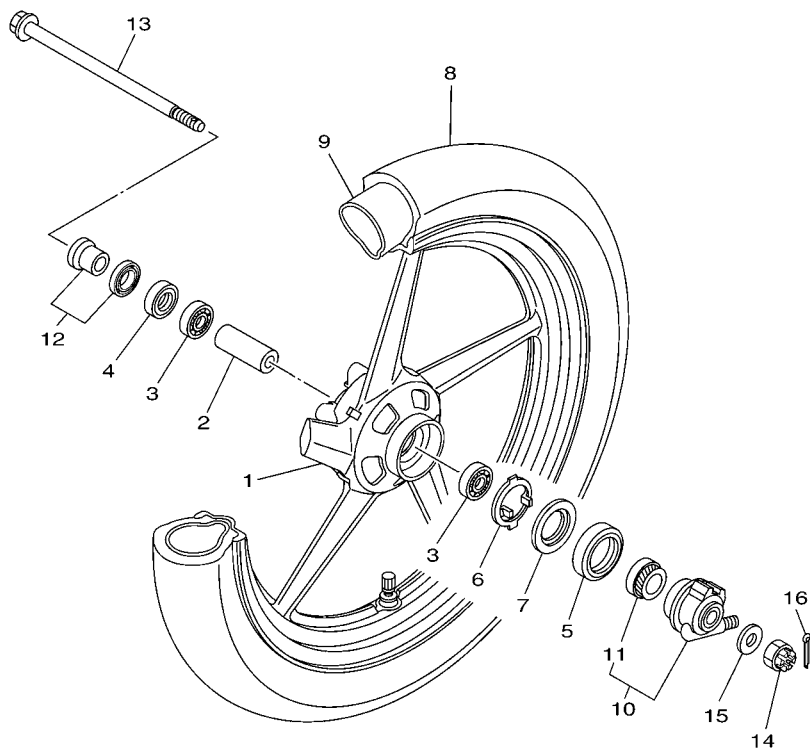

FWD
5YYE470-F250

REF. Nº	CODIGO Nº PART NO.	DESCRIPCION DESCRIPTION	22P2				OBSERVACIONES REMARKS
1	5YY-F5168-10	RUEDA FUNDIDA DELANTERA CAST WHEEL, FRONT	1				
2	90560-15293	SEPARADOR SPACER	1				
3	93306-202Y0	COJINETE BEARING	2				
4	93106-22820	SELLO ACEITE OIL SEAL	1				
5	93105-45801	SELLO ACEITE OIL SEAL	1				
6	4UU-F5149-00	EMBRAGUE DEL CUENTAKMS CLUTCH, METER	1				
7	4UU-F5846-00	RETEN DEL EMBRAGUE RETAINER, CLUTCH	1				
8	94127-18830	NEUMATICO (2.75-18 M/C 42P) TIRE (2.75-18 M/C 42P ME22)	1				PIRELLI PIRELLI
9	94227-18810	TUBO (2.75-18) TUBE (2.75-18)	1				PIRELLI PIRELLI
10	5US-F5190-10	UNIDAD DE ENGRANAJE COMPLETA GEAR UNIT ASSY	1				
11	5US-F5135-10	.ENGRANAJE DE TRACCION .GEAR, DRIVE	1				
12	5YY-F511X-00	COLLAR COLLAR	1				
13	5YY-F5181-00	EJE DE LA RUEDA AXLE, WHEEL	1				
14	90171-14020	TUERCA ENTALLADA NUT, CASTLE	1				
15	92907-14200	ARANDELA WASHER	1				
16	91401-30030	CHAVETA PIN, COTTER	1				

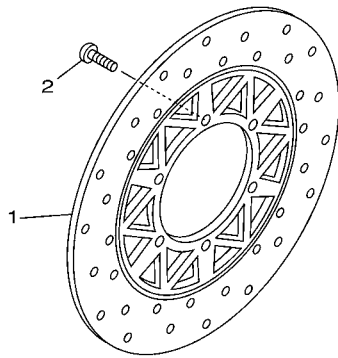
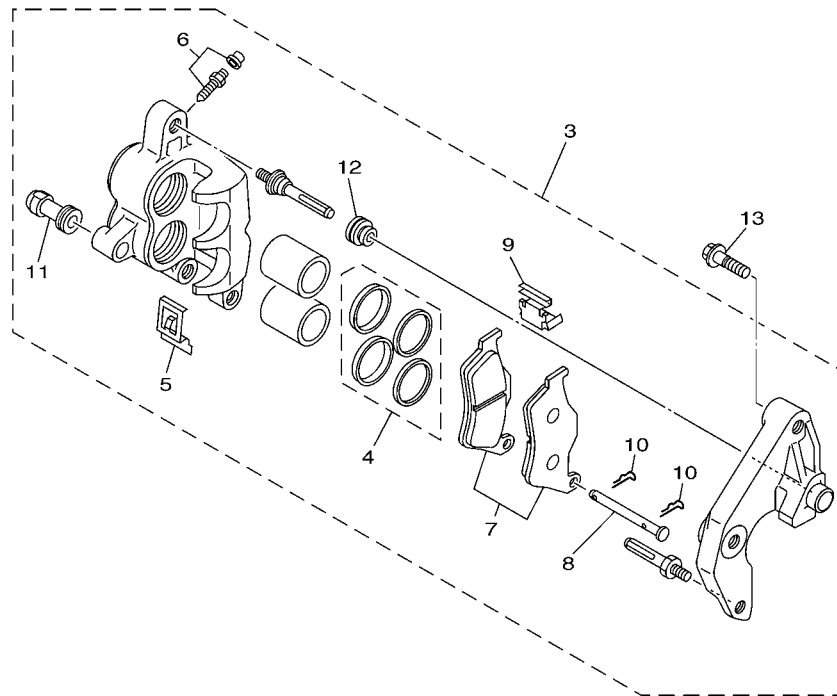

3P12481-D260

FIG. 26 CALIBRE FRENO DELANTERA FRONT BRAKE CALIPER

REF. N°	CODIGO N° PART NO.	DESCRIPCION DESCRIPTION	22P2				OBSERVACIONES REMARKS
1	5YY-F582U-00	DISCO DE FRENO (DERECHO) DISK, BRAKE (RIGHT)	1				
2	90111-08057	TORNILLO BOLT, HEX. SOCKET BUTTON	6				
3	5YY-F580U-00	CALIBRE COMPLETO (DERECHO) CALIPER ASSY (RIGHT)	1				
4	5US-W0047-00	JUEGO DE RETENES DE PINZA CALIPER SEAL KIT	1				
5	5US-F5977-00	RESORTE DE RETORNO SPRING, RETURN	1				
6	5US-W0048-00	CJTO TORNILLO DE PURGA BLEED SCREW KIT	1				
7	5US-W0045-00	JUEGO DE COJIN DE FRENO BRAKE PAD KIT	1				
8	5US-F5744-00	PASADOR 2 PIN 2	1				
9	5US-F5827-00	CUNA DE CALIBRE SHIM, CALIPER	1				
10	5US-W0016-00	PRESILLA CLIP	1				
11	5US-W0068-00	AISLANTE INSULATOR	1				
12	5US-W0053-00	PUZOS DUST COVER	1				
13	90109-100G0	PERNO BOLT	2				

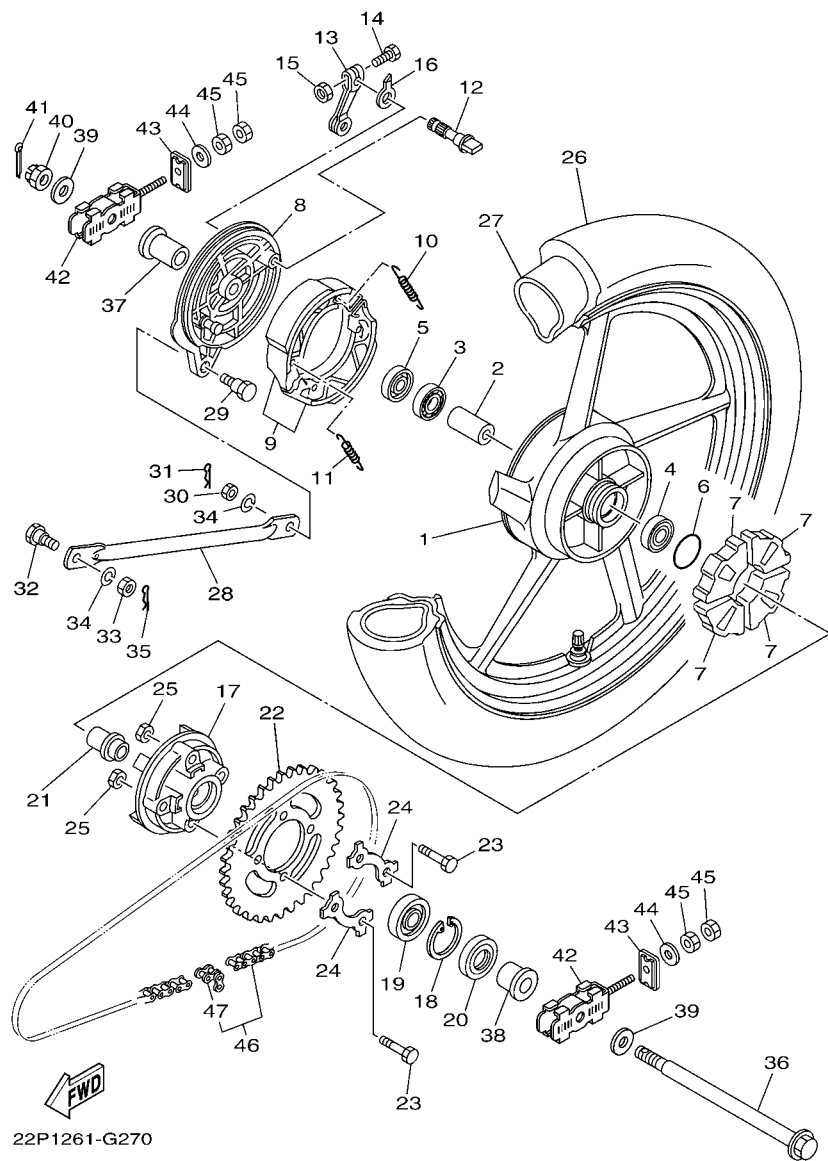

FIG. 27 RUEDA TRASERA

REAR WHEEL

REF. Nº	CODIGO Nº PART NO.	DESCRIPCION DESCRIPTION	22P2				OBSERVACIONES REMARKS
1	5YY-F5338-10	RUEDA FUNDIDA TRASERA CAST WHEEL, REAR	1				
2	90560-15136	SEPARADOR SPACER	1				
3	93306-202Y0	COJINETE BEARING	1				
4	93306-202Y1	COJINETE BEARING	1				
5	93104-22805	SELLO ACEITE OIL SEAL	1				
6	93210-42807	ANILLO O O-RING	1				
7	36L-F5364-00	AMORTIGUADOR DAMPER	4				
8	5US-F5321-10	PLACA DE ZAPATA DE FRENO PLATE, BRAKE SHOE	1				
9	5YY-WF533-00	JUEGO DE ZAPATA DE FRENO BRAKE SHOE KIT	1				
10	90506-12001	RESORTE DE TENSION SPRING, TENSION	1				
11	90506-15001	RESORTE DE TENSION SPRING, TENSION	1				
12	5YY-F5351-10	ARBOL DE LEVAS CAMSHAFT	1				
13	35B-F5355-00	PALANCA DE ARBOL DE LEVAS LEVER, CAMSHAFT	1				
14	90101-06278	TORNILLO BOLT	1				
15	95307-06600	TUERCA NUT	1				
16	36L-F533A-10	PLACA INDICADOR PLATE, INDICATOR	1				
17	5TS-F5366-00	EMBRAGUE DE MASA CLUTCH, HUB	1				
18	93420-42801	SEGURO CIRCLIP	1				
19	93306-004Y0	COJINETE BEARING	1				
20	93106-26801	SELLO ACEITE OIL SEAL	1				
21	22P-F5387-00	EJE DE CORONA AXLE, SPROCKET	1				
22	22P-F5445-00	CORONA (45T) SPROCKET, DRIVEN (45T)	1				
23	90109-08201	PERNO BOLT	4				
24	4JF-F5412-10	ARANDELA WASHER	2				
25	90179-08639	TUERCA NUT	4				
26	94130-18824	NEUMATICO(3.00-18M/C REINF52P) TIRE(3.00-18M/C REINF52P ME22)	1				PIRELLI PIRELLI
27	94227-18810	TUBO (2.75-18) TUBE (2.75-18)	1				PIRELLI PIRELLI

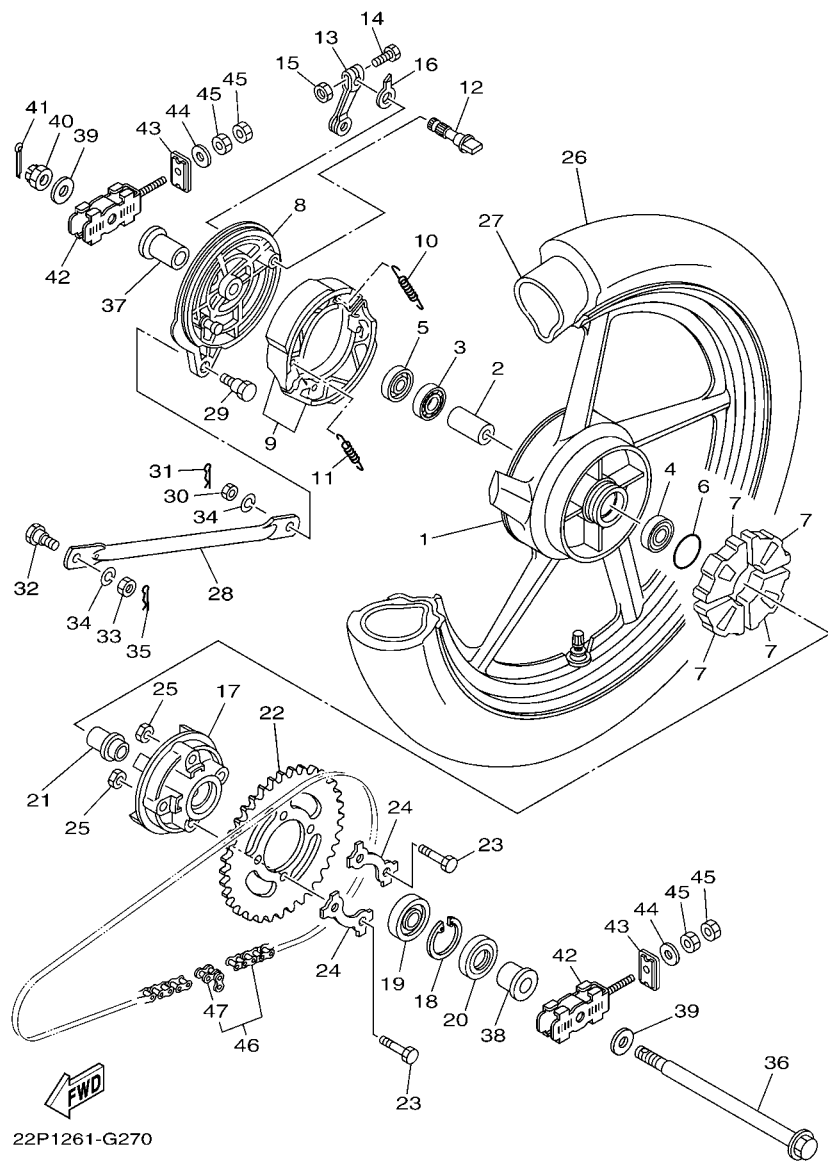

FIG. 27 RUEDA TRASERA

REAR WHEEL

REF. Nº	CODIGO Nº PART NO.	DESCRIPCION DESCRIPTION	22P2				OBSERVACIONES REMARKS
28	5VA-F5371-00	BARRA TENSORA BAR, TENSION	1				
29	90109-08063	PERNO BOLT	1				
30	95307-08700	TUERCA NUT	1				
31	90468-12007	PRESILLA CLIP	1				
32	90109-08831	PERNO BOLT	1				
33	95307-08600	TUERCA NUT	1				
34	92907-08100	ARANDELA WASHER, SPRING	2				
35	90468-12007	PRESILLA CLIP	1				
36	5YY-F5381-00	EJE DE RUEDA AXLE, WHEEL	1				
37	90387-15808	ESPACIADOR COLLAR	1				
38	90387-15806	ESPACIADOR COLLAR	1				
39	90201-15023	ARANDELA PLANA WASHER, PLATE	2				
40	90171-14037	TUERCA ENTALLADA NUT, CASTLE	1				
41	91401-30030	CHAVETA PIN, COTTER	1				
42	22P-F5389-00	TIRADOR DE CADENA 2 PULLER, CHAIN 2	2				
43	22P-F539F-00	PLACA 1 PLATE 1	2				
44	9290N-06200	ARANDELA WASHER	2				
45	9530N-06600	TUERCA NUT	4				
46	94568-A3119	CADENA CHAIN	1				
47	94668-81001	.CONECTOR DE CADENA .JOINT, CHAIN	1				

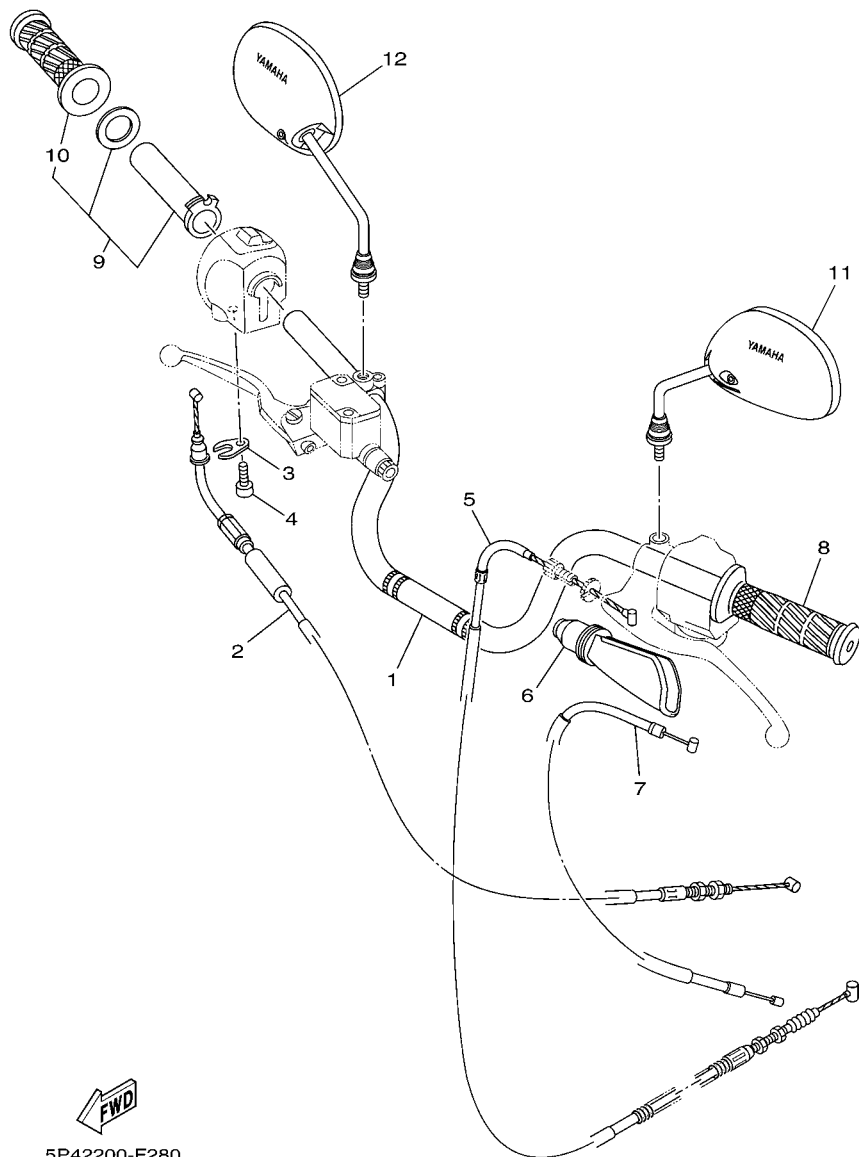

FIG. 28 MANILLAR & CABLE

STEERING HANDLE & CABLE

REF. N°	CODIGO N° PART NO.	DESCRIPCION DESCRIPTION	22P2				OBSERVACIONES REMARKS
1	22P-F6111-00	MANUBRIO HANDLEBAR	1				
2	5YY-F6311-30	CABLE DE ACELERADOR 1 CABLE, THROTTLE 1	1				
3	5US-F6393-00	SOPORTE HOLDER	1				
4	98507-05010	TORNILLO DE CABEZA CON PLANA SCREW, PAN HEAD	1				
5	5YY-F6335-10	CABLE DE EMBRAGUE CABLE, CLUTCH	1				
6	4TL-F6372-00	CUBIERTA DE PALANCA DE MANUB 1 COVER, HANDLE LEVER 1	1				
7	5YY-F6331-00	CABLE DE ARRANQUE CABLE, STARTER 1	1				
8	4UU-F6241-00	EMPUNADURA GRIP	1				
9	4UU-F6240-00	EMPUNADURA COMPLETA GRIP ASSY	1				
10	4UU-F6242-00	EMPUNADURA (MD) GRIP (RIGHT)	1				
11	5YY-F6280-00	ESPEJO COMPLETO (IZQUIERDO) REAR VIEW MIRROR ASSY (LEFT)	1				
12	5YY-F6290-00	ESPEJO COMPLETO (DERECHO) REAR VIEW MIRROR ASSY (RIGHT)	1				

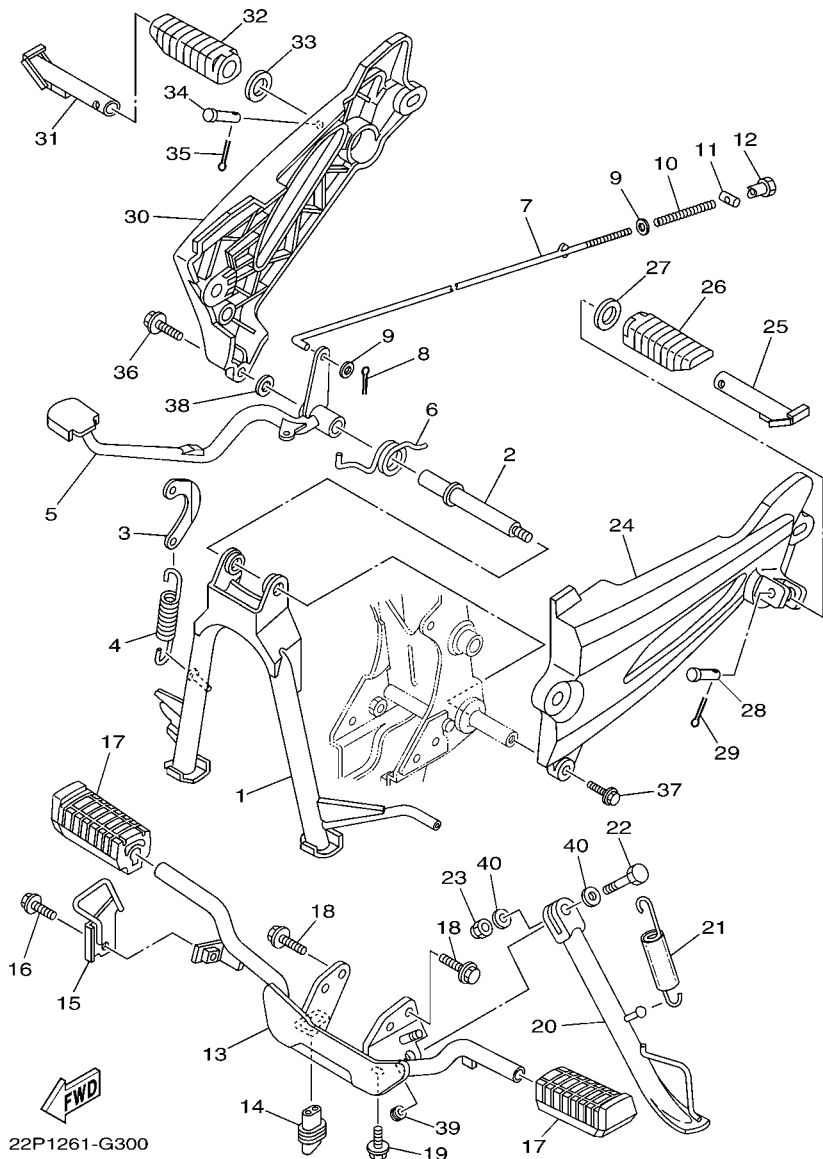

FIG. 30 SOPORTE & APOYAPIE

STAND & FOOTREST

REF. Nº	CODIGO Nº PART NO.	DESCRIPCION DESCRIPTION	22P2				OBSERVACIONES REMARKS
1	22P-F7111-00	PUNTAL PRINCIPAL STAND, MAIN	1				
2	22P-F7112-00	EJE DE PUNTAL PRINCIPAL SHAFT, MAIN STAND	1				
3	5C9-F7115-00	CONEXION DE PUNTAL PRINCIPAL LINK, MAIN STAND	1				
4	90506-32800	RESORTE DE TENSION SPRING, TENSION	1				
5	5YY-F7211-00	PEDAL DE FRENO PEDAL, BRAKE	1				
6	90508-40807	RESORTE DE TORSION SPRING, TORSION	1				
7	22P-F7231-00	VARILLA DE FRENO ROD, BRAKE	1				
8	91401-20012	CHAVETA PIN, COTTER	1				
9	92907-06200	ARANDELA WASHER	2				
10	90501-10245	RESORTE DE COMPRESION SPRING, COMPRESSION	1				
11	90249-12008	PASADOR PIN	1				
12	90179-06411	TUERCA NUT	1				
13	22P-F7411-00	APOYAPIE 1 FOOTREST 1	1				
14	5YY-H2109-00	UNION, TUBO JOINT, HOSE	1				
15	5TS-F743H-00	TOPE,3 STOPPER,3	1				
16	95807-06014	TORNILLO BOLT, FLANGE	1				
17	5YY-F7413-00	CUBIERTA DE APOYAPIE COVER, FOOTREST	2				
18	95817-08025	TORNILLO BOLT, FLANGE	2				
19	95817-08016	TORNILLO BOLT, FLANGE	1				
20	22P-F7311-00	PUNTAL LATERAL STAND, SIDE	1				
21	90506-29800	RESORTE DE TENSION SPRING, TENSION	1				
22	90101-10034	TORNILLO BOLT	1				
23	90185-10091	TUERCA AUTOBLOCANTE NUT, SELF-LOCKING	1				
24	5YY-F741L-00	MENSULA 4 BRACKET 4	1				
25	5TS-F7431-11	APOYAPIE POSTERIOR 1 FOOTREST, REAR 1	1				
26	5TS-F7433-00	CUBIERTA APOYAPIE TRASERO COVER, REAR FOOTREST	1				
27	90202-20800	ARANDELA DE PLANA WASHER, PLATE	1				

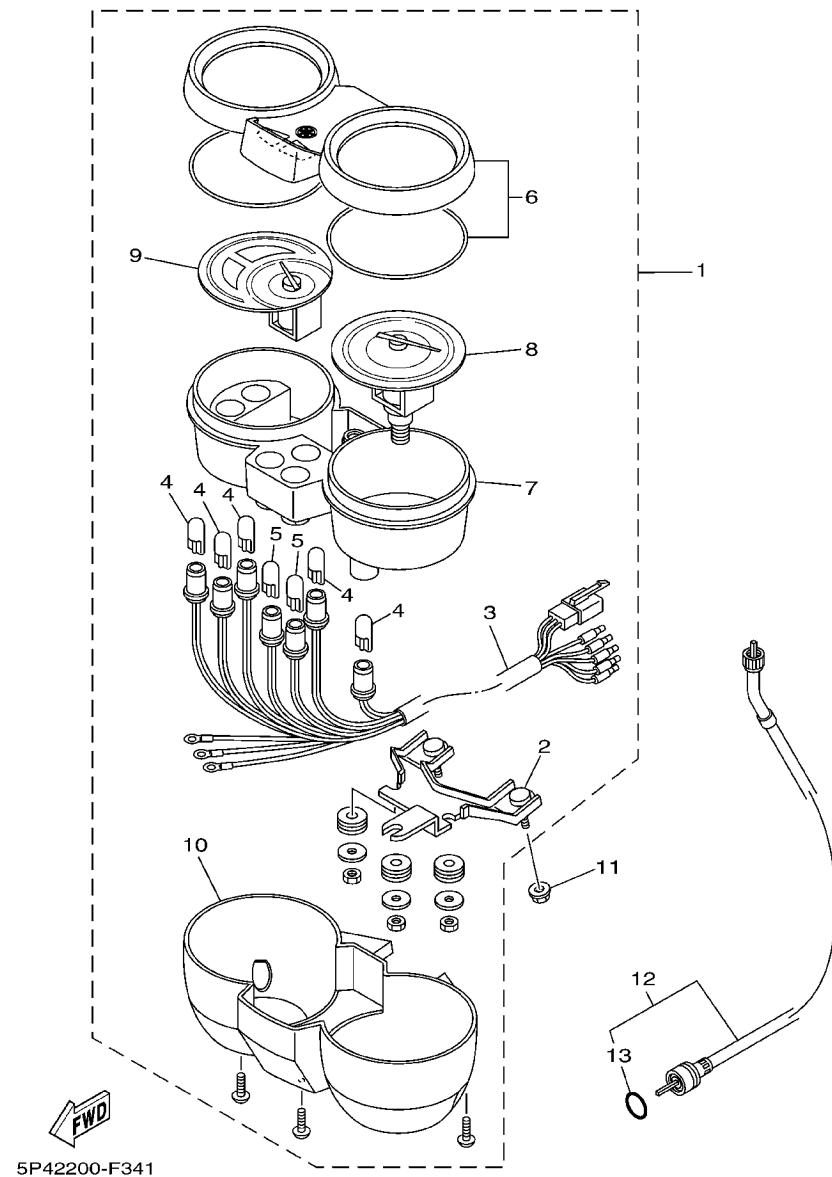

FIG. 34 MEDIDOR

METER

REF. N°	CODIGO N° PART NO.	DESCRIPCION DESCRIPTION	22P2				OBSERVACIONES REMARKS
1	5YY-H3500-10	METRO COMPLETO METER ASSY	1				
2	5TS-H3519-00	.SOPORTE DE MEDIDOR .BRACKET, METER	1				
3	5HH-H350W-00	.ENCASTRE DE CABLE COMPLETO .SOCKET CORD ASSY	1				
4	5HH-H3518-00	.BOMBILLA (12V-3.4W) .BULB (12V-3.4W)	5				
5	5HH-H3517-00	.BOMBILLA (14V-3W T6.5) .BULB (14V-3W T6.5)	2				
6	5YY-H353E-10	.CAJA DE MEDIDOR SUPERIOR .COVER, SPEEDOMETER	1				
7	5YY-H353F-10	.CAJA DE MEDIDOR INFERIOR .CASE, METER LOWER	1				
8	5YY-H3570-10	.VELOCIMETRO COMPLETO .SPEEDOMETER ASSY	1				
9	5YY-H5750-00	.MEDIDOR DE COMBUSTIBLE COMPL. .FUEL METER ASSY	1				
10	5YY-H353H-10	.CAJA INFERIOR .CASE, UNDER	1				
11	95707-06500	TUERCA DE BRIDA NUT, FLANGE	2				
12	5YY-H3550-30	CABLE DE VELOCIMETRO COMPLETO SPEEDOMETER CABLE ASSY	1				
13	93210-14806	.ANILLO O .O-RING	1				

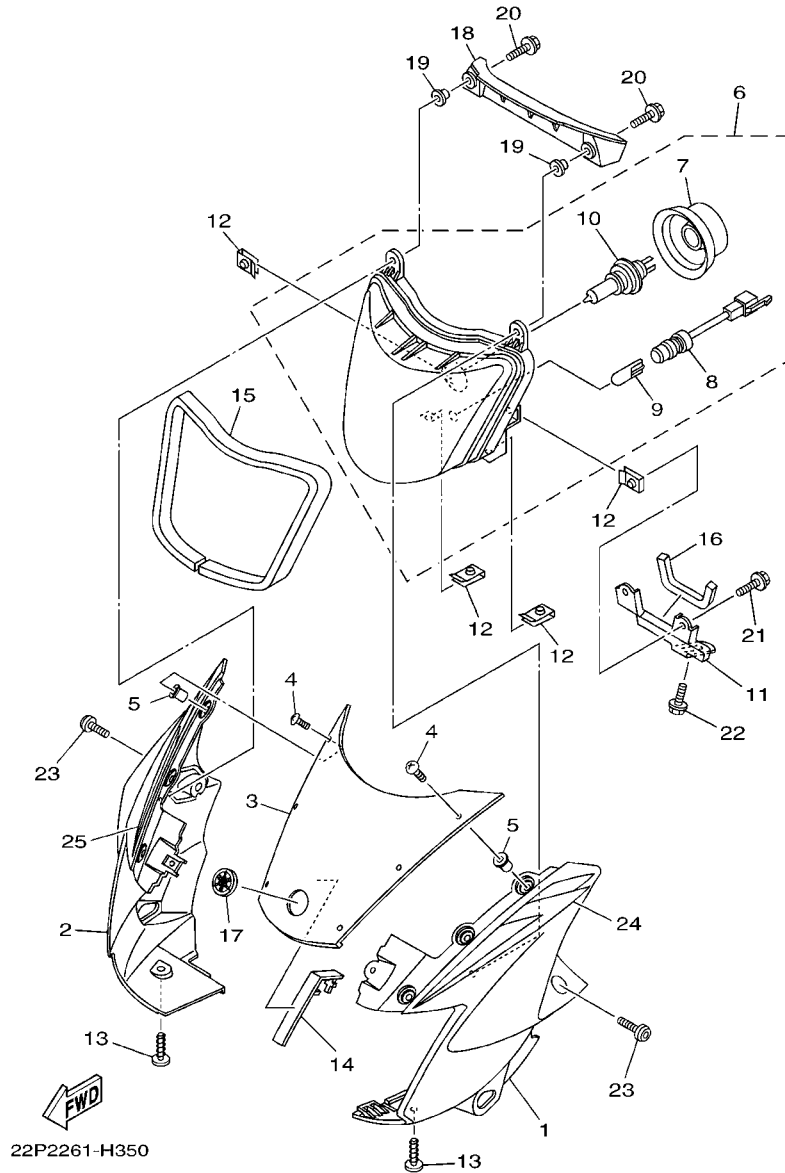

FIG. 35 FARO DELANTERO

HEADLIGHT

REF. N°	CODIGO Nº PART NO.	DESCRIPCION DESCRIPTION	22P2			OBSERVACIONES REMARKS
1	22P-F8351-00-P0	CUERPO DE COBERTURA BODY, COWLING	1			UR PARA VRC1 UR FOR VRC1
	22P-F8351-00-33	CUERPO DE COBERTURA BODY, COWLING	1			UR PARA YB UR FOR YB
	22P-F8351-00-WG	CUERPO DE COBERTURA BODY, COWLING	1			UR PARA HTS UR FOR HTS
	22P-F8351-00-P1	CUERPO DE COBERTURA BODY, COWLING	1			UR PARA DPBMC UR FOR DPBMC
2	22P-F8377-00-P0	CUERPO, DE COBERTURE 2 BODY, COWLING 2	1			UR PARA VRC1 UR FOR VRC1
	22P-F8377-00-33	CUERPO, DE COBERTURE 2 BODY, COWLING 2	1			UR PARA YB UR FOR YB
	22P-F8377-00-WG	CUERPO, DE COBERTURE 2 BODY, COWLING 2	1			UR PARA HTS UR FOR HTS
	22P-F8377-00-P1	CUERPO, DE COBERTURE 2 BODY, COWLING 2	1			UR PARA DPBMC UR FOR DPBMC
3	5YY-F8381-30	PARABRISA WINDSHIELD	1			
4	90150-05023	TORNILLO CABEZA REDONDA SCREW, ROUND HEAD	6			
5	90179-05523	TUERCA NUT	6			
6	22P-H4310-00	UNIDAD DE FARO DELANTERO COMPL HEADLIGHT UNIT ASSY	1			
7	5YY-H4196-20	.CUBIERTA, DE ENCASTRE .COVER, SOCKET	1			
8	5YY-H4312-10	.CABLE COMPLETA .CORD ASSY	1			
9	5YY-H4347-10	.BOMBILLA (12V 5W) .BULB (12V 5W)	1			
10	5YY-H4314-20	.BOMBILLA DE FARO DELANTERO .BULB, HEADLIGHT (12V 35/35W)	1			
11	22P-F317R-00	SOPORTE 5 STAY 5	1			
12	90183-05814	TUERCA DE RESORTE NUT, SPRING	7			
13	90154-05051	TORNILLO DE LIGAR SCREW, BINDING	3			
14	5YY-F8365-00	CUBIERTA COVER	1			
15	5YY-H4345-10	AMORT DE FARO DELANTERO DAMPER, HEADLIGHT	1			
16	5YY-H4527-00	AMORTIGUADOR DAMPER	1			
17	22P-F836B-00	MARCA TUNING FORK MARK	1			
18	5YY-H3559-00	CUBIERTA DE MEDIDOR COVER, METER	1			
19	90387-058W5	ESPACIADOR COLLAR	2			
20	90119-05020	TORNILLO CON ARANDELA BOLT, WITH WASHER	2			
21	90119-05020	TORNILLO CON ARANDELA BOLT, WITH WASHER	2			

FIG. 35 FARO DELANTERO

HEADLIGHT

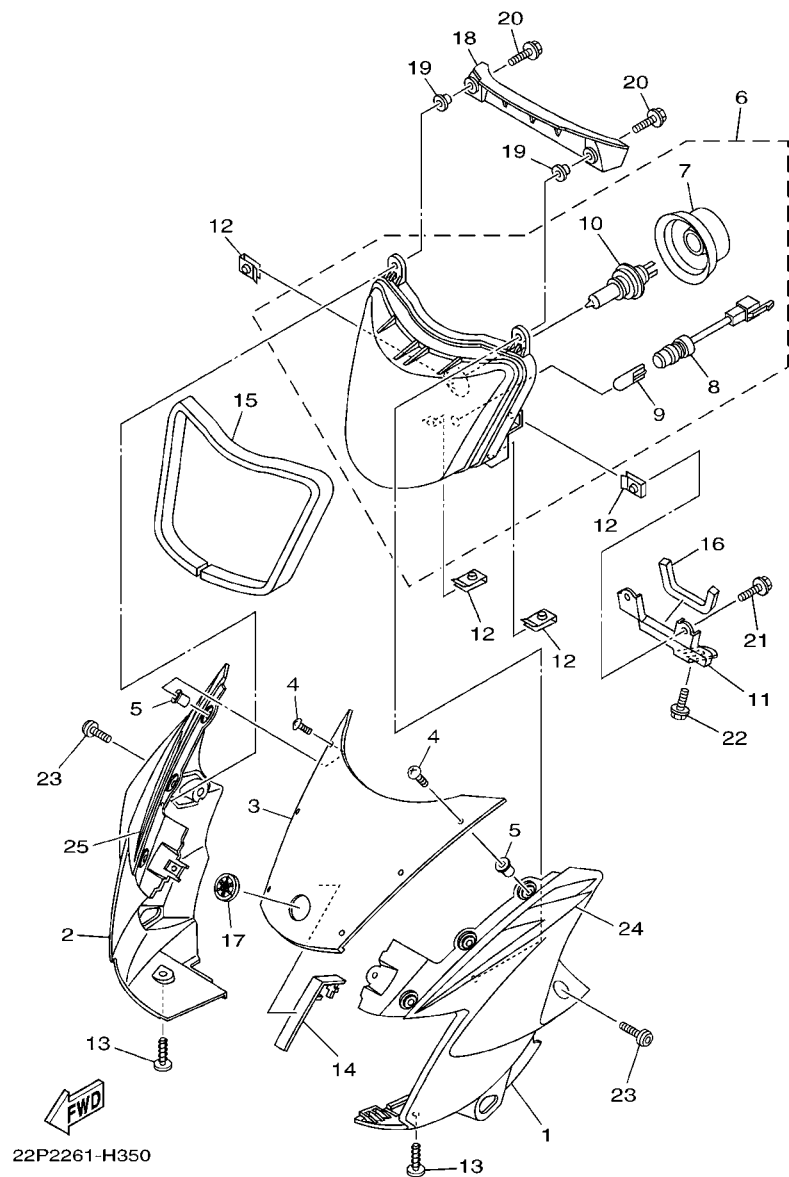

REF. Nº	CODIGO Nº PART NO.	DESCRIPCION DESCRIPTION	22P2			OBSERVACIONES REMARKS
22	95807-06012	TORNILLO BOLT, FLANGE	1			
23	90111-06083	TORNILLO BOLT, HEX. SOCKET BUTTON	2			
24	22P-F8391-00	CALCOMANIA DE BOVEDA 1 GRAPHIC 1	1			UR PARA VRC1 UR FOR VRC1
	22P-F8391-10	CALCOMANIA DE BOVEDA 1 GRAPHIC 1	1			UR PARA YB UR FOR YB
	22P-F8391-20	CALCOMANIA DE BOVEDA 1 GRAPHIC 1	1			UR PARA HTS UR FOR HTS
	22P-F8391-30	CALCOMANIA DE BOVEDA 1 GRAPHIC 1	1			UR PARA DPBMC UR FOR DPBMC
25	22P-F8392-00	CALCOMANIA DE BOVEDA 2 GRAPHIC 2	1			UR PARA VRC1 UR FOR VRC1
	22P-F8392-10	CALCOMANIA DE BOVEDA 2 GRAPHIC 2	1			UR PARA YB UR FOR YB
	22P-F8392-20	CALCOMANIA DE BOVEDA 2 GRAPHIC 2	1			UR PARA HTS UR FOR HTS
	22P-F8392-30	CALCOMANIA DE BOVEDA 2 GRAPHIC 2	1			UR PARA DPBMC UR FOR DPBMC

FIG. 36 LUZ DE COLA

TAILLIGHT

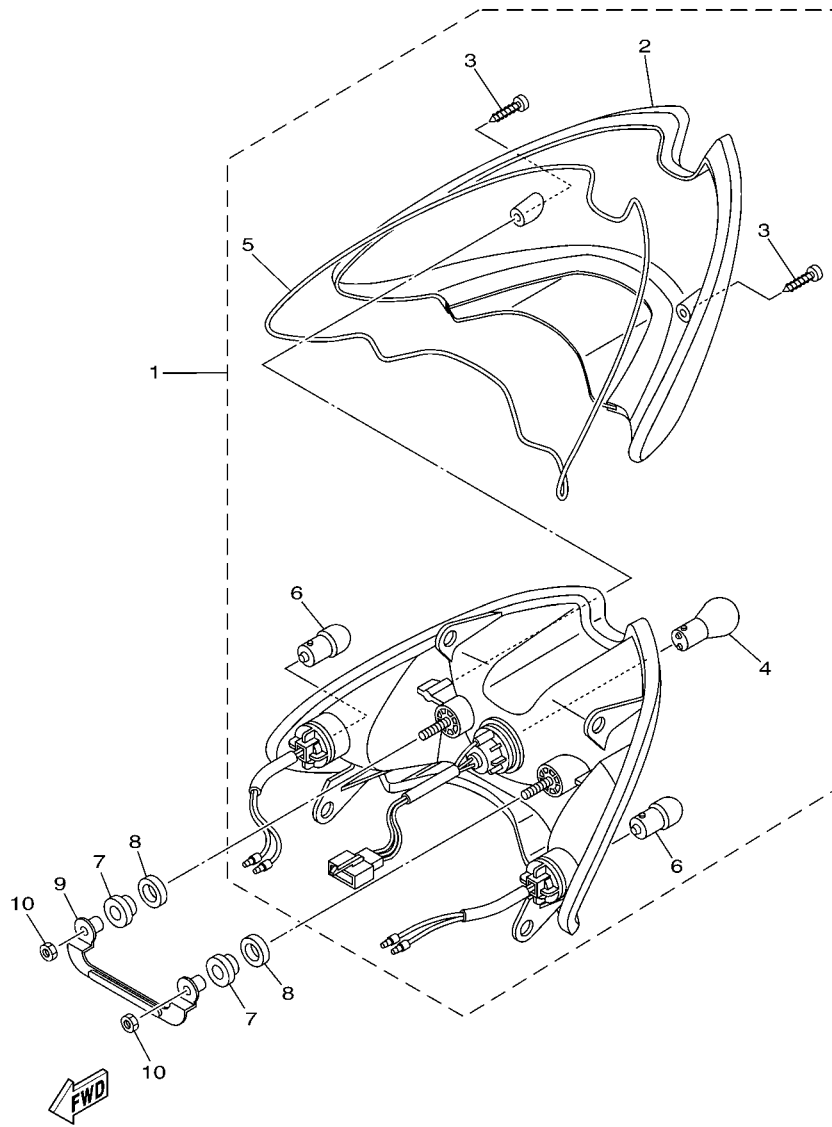

22P1261-G360

REF. N°	CODIGO N° PART NO.	DESCRIPCION DESCRIPTION	22P2				OBSERVACIONES REMARKS
1	5YY-H4710-20	UNIDAD FARO TRASERO COMPL. TAILLIGHT UNIT ASSY	1				
2	5YY-H4521-20	.LENTE DE FARO TRASERO .LENS, TAILLIGHT	1				
3	9850N-06034	.TORNILLO DE CABEZA CON PLANA .SCREW, PAN HEAD	2				
4	36L-H4714-00	.BOMBILLA (12V-21/5W) .BULB (12V-21/5W)	1				
5	5YY-H4723-10	.EMPAQUE LENTE FARO TRASERO .GASKET, TAIL LENS	1				
6	36L-H3311-20	.BOMBILLA (12V-10W) .BULB, FLASHER (12V-10W)	2				
7	5TS-H4553-00	AMORTIGUADOR DAMPER	2				
8	5TS-H4554-00	ARANDELA ESPECIAL WASHER, SPECIAL	2				
9	5YY-H4703-00	SOPORTE BRACKET	1				
10	90176-06019	TUERCA CORONA NUT, CROWN	2				

FIG. 37 INTERRUPTOR DE MANILLAR&PALANC HANDLE SWITCH & LEVER

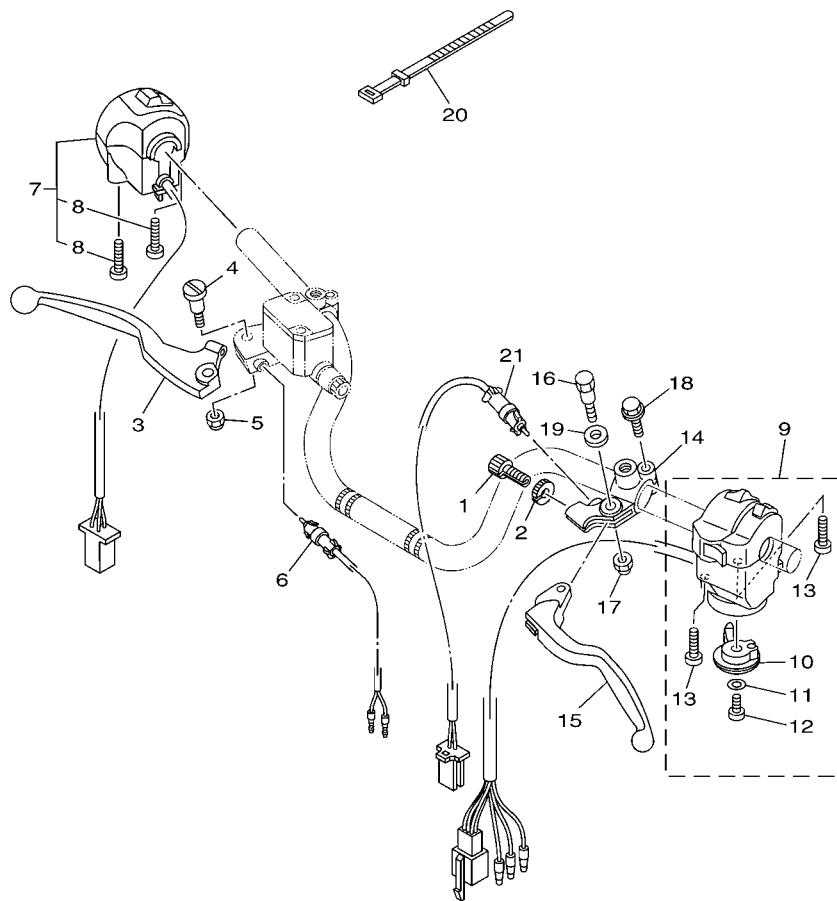

REF. N°	CODIGO N° PART NO.	DESCRIPCION DESCRIPTION	22P2				OBSERVACIONES REMARKS
1	90123-08046	PERNO BOLT	1				
2	90179-08148	TUERCA NUT	1				
3	5YY-H3922-00	PALANCA 2 LEVER 2	1				
4	90109-06859	PERNO BOLT	1				
5	90185-06802	TUERCA AUTOBLOCANTE NUT, SELF-LOCKING	1				
6	5YY-H3980-10	INTERRUP. DE PARADA DELANTERO FRONT STOP SWITCH ASSY	1				
7	5YY-H3975-00	INTERRUPTOR DE MANIJA 2 SWITCH, HANDLE 2	1				
8	98507-06918	.TORNILLO DE CABEZA PLANA .SCREW, PAN HEAD	2				
9	5YY-H3969-10	INTERRUPTOR DE MANIJA 5 SWITCH, HANDLE 5	1				
10	4TL-H3941-00	.PALANCA DE ARRANQUE .LEVER, STARTER	1				
11	92907-06200	.ARANDELA .WASHER	1				
12	98507-06008	.TORNILLO DE CABEZA PLANA .SCREW, PAN HEAD	1				
13	98507-05035	.TORNILLO DE CABEZA PLANA .SCREW, PAN HEAD	2				
14	5YY-H2911-00	SOPORTE DE LEVA 1 HOLDER, LEVER 1	1				
15	4LS-H3912-00	PALANCA 1 LEVER 1	1				
16	36L-H3945-10	PERNO DE PALANCA BOLT, LEVER	1				
17	95707-06300	TUERCA DE BRIDA NUT, NYLON	1				
18	9750M-06425	PERNO CON ARANDELA BOLT, WITH WASHER	1				
19	90201-08834	ARANDELA PLANA WASHER, PLATE	1				
20	36L-H3936-00	BANDA DE CABLE DE INTERRUPTOR BAND, SWITCH CORD	4				
21	5YY-H2917-00	INTERRUPTOR SWITCH	1				

FWD
22P1261-G370

FIG. 38 EQUIPO ELECTRICO 1

ELECTRICAL 1

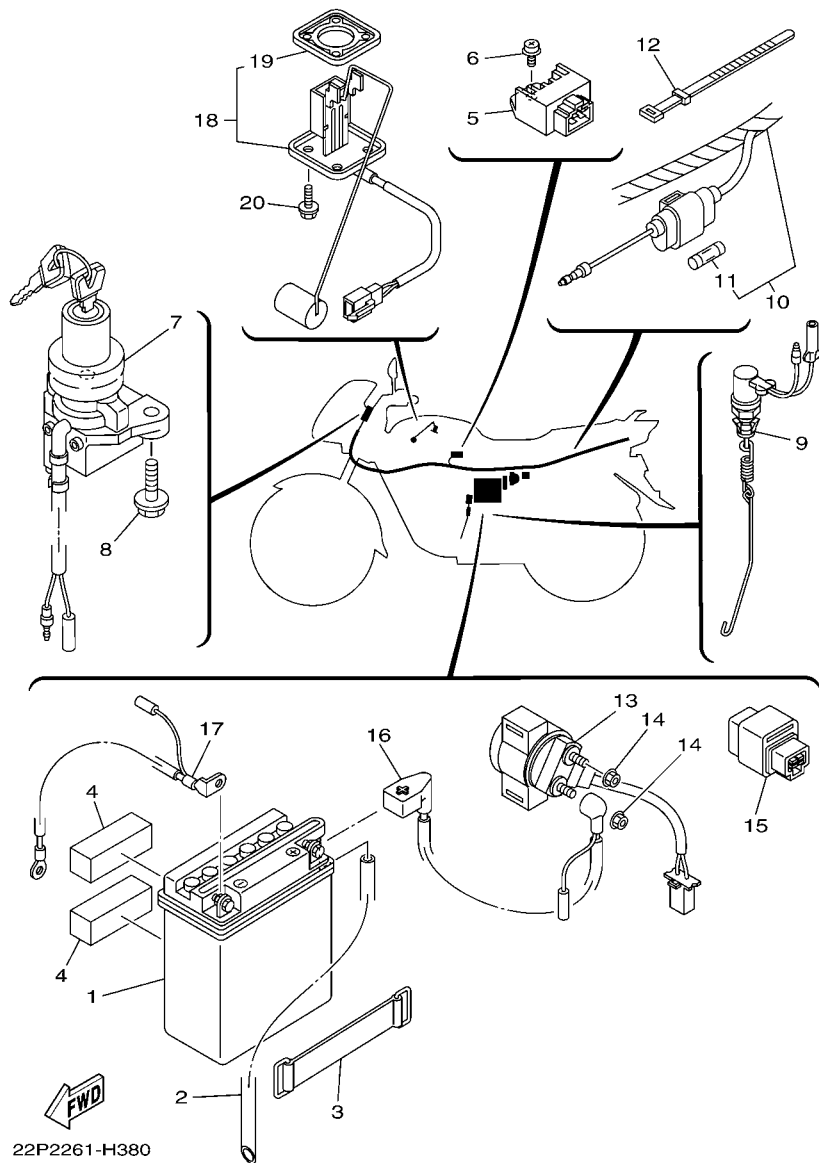

REF. N°	CODIGO N° PART NO.	DESCRIPCION DESCRIPTION	22P2				OBSERVACIONES REMARKS
1	3AY-H2110-00	BATERIA COMPLETA YB5L-B12V-5AH BATTERY ASSY (YB5L-B 12V-5AH)	1				YUASA YUASA
2	90445-08825	TUBO HOSE	1				
3	5YY-H2131-10	TIRANTE DE BATERIA BAND, BATTERY	1				
4	5TS-F1541-00	AMORTIGUADOR 1 DAMPER 1	2				
5	5YY-H1960-10	RECTIFICADOR Y REGULADOR RECTIFIER & REGULATOR ASSY	1				
6	97607-06214	TORNILLO CAB CON PLANA C/ARAN SCREW, WITH WASHER	1				
7	5TS-H2501-11	LLAVE DE IGNICION COMPLT MAIN SWITCH STEERING LOCK	1				
8	90149-06002	TORNILLO DE REGLAJE SCREW	2				
9	5TS-H2530-01	INTERRUPTOR DE PARADA COMPLETO STOP SWITCH ASSY	1				
10	22P-H2590-00	CONJUNTO DE CABLES WIRE HARNESS ASSY	1				UR UR
	5YY-H2590-50	CONJUNTO DE CABLES WIRE HARNESS ASSY	1				UR UR
11	36L-H2151-V0	.FUSIBLE (10A) .FUSE (10A)	2				
12	5TS-H3936-01	BANDA DE CABLE DE INTERRUPTOR BAND, SWITCH CORD	1				
13	5US-H1940-00	CONJUNTO ARRANCADOR RELEVO STARTER RELAY ASSY	1				
14	95702-06500	TUERCA DE REBORDE NUT, FLANGE	2				
15	5YY-H1950-00	RELE COMPLETO RELAY ASSY	1				
16	5YY-H2115-00	CABLE CONDUCTOR POSITIVO WIRE, PLUS LEAD	1				
17	5YY-H2116-00	CABLE CONDUCTOR NEGATIVO WIRE, MINUS LEAD	1				
18	5YY-H5701-00	MEDIDOR DE COMBUSTIBLE COMPL. SENDER ASSY	1				
19	5TS-H5753-20	.EMPAQUE DE UNIDAD TRANSMISORA .GASKET, SENDER UNIT	1				
20	90105-05361	TORNILLO BOLT, FLANGE	4				

FIG. 39 EQUIPO ELECTRICO 2

ELECTRICAL 2

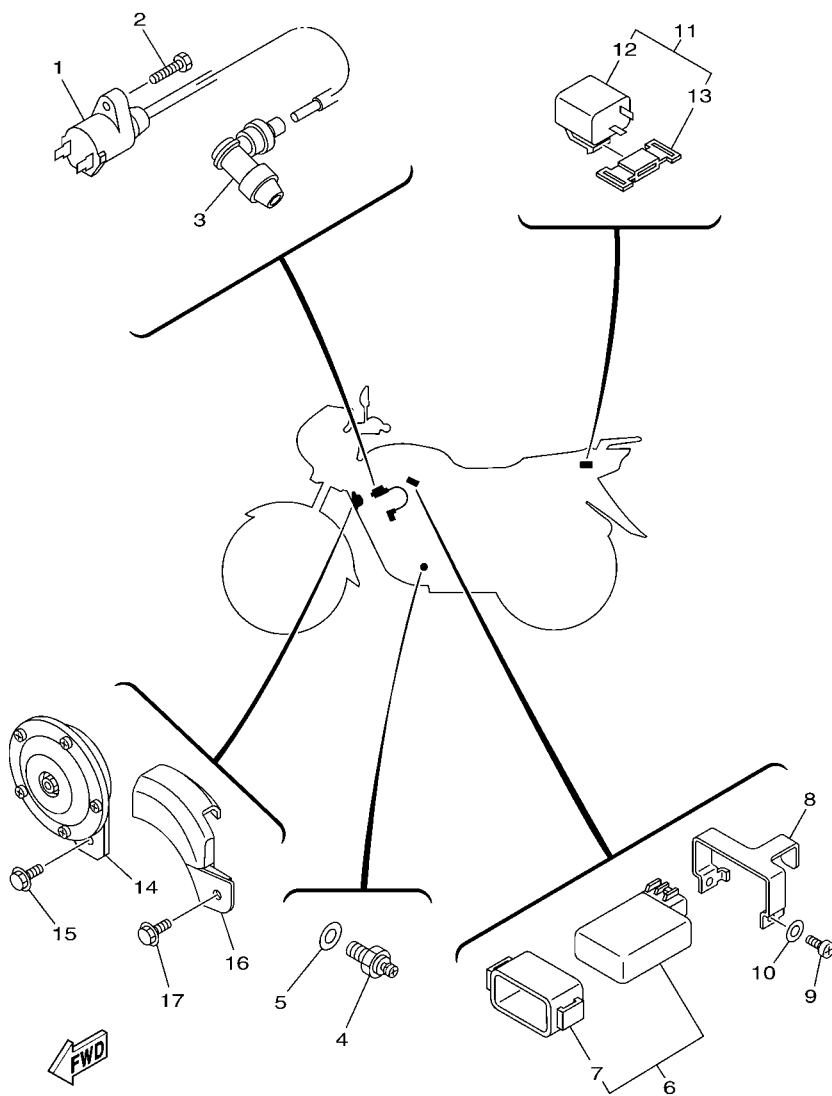

22P1261-G390

REF. Nº	CODIGO Nº PART NO.	DESCRIPCION DESCRIPTION	22P2				OBSERVACIONES REMARKS
1	5YY-H2310-00	BOBINA DE ENCENDIDO COMPLETA IGNITION COIL ASSY	1				
2	97007-05025	PERNO BOLT	1				
3	5YY-H2370-00	TAPON DE BUJIA COMPLT PLUG CAP ASSY	1				
4	4LS-H2540-00	INTERRUPTOR NEUTRAL COMPL NEUTRAL SWITCH ASSY	1				
5	90430-10148	JUNTA GASKET	1				
6	5YY-H5540-10	UNIDAD C.D.I. COMPLETA C.D.I. UNIT ASSY	1				
7	5YY-H5546-00	.BANDA .BAND	1				
8	5YY-H5542-00	SOPORTE BRACKET	1				
9	9850N-05010	TORNILLO DE CABEZA CON PLANA SCREW, PAN HEAD	2				
10	9290N-05200	ARANDELA WASHER	2				
11	5YY-H3350-00	RELE DE DESTELLADOR COMPL. FLASHER RELAY ASSY	1				
12	5KA-H3351-00	.RELE .RELAY, FLASHER	1				
13	5YY-H1952-00	.SOSTEN DE RELE .HOLDER, RELAY	1				
14	5YY-H3371-10	BOCINA HORN	1				
15	95807-06012	TORNILLO BOLT, FLANGE	1				
16	5YY-H3376-00	CUBIERTA DE BOCINA COVER, HORN	1				
17	90119-06044	TORNILLO CON ARANDELA BOLT, WITH WASHER	1				

INDICE NUMERICO
NUMERICAL INDEX

CODIGO Nº PART NO.	REF. Nº	CODIGO Nº PART NO.	REF. Nº	CODIGO Nº PART NO.	REF. Nº	CODIGO Nº PART NO.	REF. Nº	CODIGO Nº PART NO.	REF. Nº	CODIGO Nº PART NO.	REF. Nº
2TK-11633-00	2 - 4	4LS-E2118-00	3 - 6	5YY-E5418-00	10 - 13	4LS-E8512-00	15 - 6	22P-F173E-00	19 - 16	36L-F3158-00	22 - 6
2LN-14122-00	7 - 19	4LS-E2119-00	3 - 3	5YY-E5421-10	10 - 15	4LS-E8513-00	15 - 7	22P-F173E-10	19 - 16		22 - 24
5K7-14134-00	7 - 12	4LS-E2121-10	3 - 2	4LS-E5441-00	9 - 12	36L-E8531-00	15 - 8	22P-F173E-20	19 - 16	36L-F3159-00	22 - 41
22F-14139-00	7 - 29	5YY-E2151-00	3 - 8	5YY-E5451-00	10 - 3	36L-E8535-00	15 - 9	22P-F173E-30	19 - 16	36L-F3168-00	22 - 19
5LW-14141-00	7 - 15	4LS-E2156-00	3 - 11	5YY-E5461-01	10 - 16	5YY-E8540-10	15 - 1	22P-F173F-00	19 - 17		22 - 37
5LW-14142-15	7 - 16	4LS-E2159-01	3 - 9	5VL-E5512-00	12 - 1	22P-F1110-01	17 - 1	22P-F173F-10	19 - 17	5YY-F3170-00	22 - 9
3H1-14147-00	7 - 13	5YY-E2170-00	4 - 1	5VL-E5517-00	12 - 5	22P-F1316-00	17 - 2	22P-F173F-20	19 - 17		22 - 27
5HK-14147-00	7 - 25	5YY-E2176-00	4 - 5	5US-E5521-00	12 - 2	22P-F1317-00	17 - 7	22P-F173F-30	19 - 17	5US-F3173-00	22 - 8
353-14186-00	7 - 23	5YY-E2210-20	4 - 13	5US-E5532-00	12 - 3	22P-F1318-00	17 - 8	5YY-F1773-00	19 - 4		22 - 26
4TL-14191-00	7 - 27	5YY-E2213-00	4 - 14	4FP-E5580-00	12 - 7	22P-F137N-00	23 - 34	5YY-F1773-10	19 - 5	5YY-F317J-00	21 - 17
5YY-14192-00	7 - 6	5YY-E2231-00	4 - 9	4FP-E5583-01	12 - 9	22P-F137N-10	23 - 34	5YY-F1778-00	23 - 28	22P-F317R-00	35 - 11
2AL-14196-00	7 - 30	5YY-E2241-00	4 - 10	4LS-E5598-00	4 - 11	22P-F137N-20	23 - 34	5YY-F1778-00	19 - 6	36L-F3181-00	22 - 7
5YY-14197-00	7 - 9	5YY-E3300-00	5 - 1	36L-E5618-00	11 - 17	22P-F137N-30	23 - 34	5YY-F177G-00	19 - 12		22 - 25
3EN-14239-00	7 - 31	4LS-E3324-00	5 - 13	5YY-E5620-10	11 - 11	22P-F137P-00	23 - 35	2YA-F1780-00	19 - 7	22P-F331A-00	21 - 16
3G2-1423A-76	7 - 20	5KA-E3325-20	5 - 2	5DG-E5621-00	11 - 12	22P-F137P-10	23 - 35	22P-F2110-00	20 - 1	5YY-F3345-10	22 - 38
5LW-14261-00	7 - 17	4LS-E3329-00	5 - 8	5YY-E5641-00	11 - 2	22P-F137P-20	23 - 35	5TS-F2123-00	20 - 2	36L-F3346-00	22 - 40
5YY-14390-00	7 - 21	4LS-E3411-00	5 - 12	5RE-E5651-00	11 - 8	22P-F137P-30	23 - 35	5YY-F2126-00	20 - 16	5YY-F3389-10	21 - 20
5LW-14589-00	7 - 4	4LS-E3451-00	5 - 14	5YY-E5661-00	11 - 1	22P-F137U-00-33	23 - 23	5YY-F2141-00	20 - 3	5KA-F3411-00	22 - 42
5YY-14923-20	7 - 11	5YY-E3586-00	6 - 1	5YY-E5666-00	11 - 7	22P-F137U-00-P0	23 - 23	5YY-F2151-00	20 - 7	5KA-F3412-00	21 - 1
4BH-14934-00	7 - 18	5UC-E4137-00	6 - 22	5YY-E5671-00	11 - 5	22P-F137U-00-P1	23 - 23	22P-F2210-00	20 - 12	5KA-F3413-00	21 - 2
5LW-14958-00	7 - 3	5YY-E4411-00	6 - 5	5RE-E6111-00	13 - 1	22P-F137U-00-WG	23 - 23	22P-F2311-00	20 - 9	5KA-F3414-00	21 - 3
3H1-14962-00	7 - 14	5YY-E4412-00	6 - 6	5YY-E6150-20	13 - 5	22P-F137V-00-33	23 - 25	5YY-F3100-33	22 - 1	5YY-F3416-00	21 - 6
5YY-14981-00	7 - 26	5TS-E4415-00	6 - 18	5YY-E6154-00	13 - 6	22P-F137V-00-P0	23 - 25	5YY-F3102-33	22 - 2	4LS-F3418-00	21 - 8
5HK-14985-00	7 - 22	5YY-E4437-00	6 - 12	5YY-E6321-00	13 - 8	22P-F137V-00-P1	23 - 25	5YY-F3103-33	22 - 20	4LS-F341E-00	21 - 5
5YY-24411-10	7 - 7	5TS-E443E-00	6 - 15	5RE-E6324-10	13 - 9	22P-F137V-00-WG	23 - 25	5YY-F3106-10	22 - 3	4LS-F341E-10	21 - 4
5US-25852-00	29 - 7	5TS-E4450-00	6 - 7	5RE-E6351-00	13 - 10	22P-F137W-00-33	23 - 22	5YY-F3107-10	22 - 21	5YY-F3435-20	21 - 10
5US-25854-00	29 - 6	5TS-E4451-00	6 - 9	4LS-E6356-00	13 - 14	22P-F137W-00-P0	23 - 22	5YY-F3110-00	22 - 12	5TS-F3441-01	21 - 14
4LS-E1111F-00	4 - 3	5YY-E4453-00	6 - 11	4LS-E6357-00	13 - 20	22P-F137W-00-P1	23 - 22		22 - 30	5YY-F3462-00	22 - 39
4LS-E1161-00	1 - 4	5TS-E4458-00	6 - 8	4LS-E6358-00	13 - 13	22P-F137W-00-WG	23 - 22	36L-F3111-00	22 - 17	22P-F4110-02-33	23 - 1
5YY-E1166-00	9 - 1	5TS-E4459-00	6 - 19	5KA-E6371-10	13 - 7	22P-F137X-00-33	23 - 24		22 - 35	22P-F4110-02-P0	23 - 1
4LS-E1167-00	9 - 5	5TS-E4461-00	6 - 10	4LS-E6381-00	13 - 21	22P-F137X-00-P0	23 - 24	5YY-F3118-10	22 - 16	22P-F4110-02-P1	23 - 1
4LS-E1181-00	1 - 12	5TS-E446R-00	6 - 17	5YY-E7211-10	14 - 13	22P-F137X-00-P1	23 - 24		22 - 34	22P-F4110-02-WG	23 - 1
5YY-E1185-00	1 - 3	3AH-E4613-00	8 - 8	5YY-E7221-10	14 - 8	22P-F137X-00-WG	23 - 24	5YY-F3141-10	22 - 14	22P-F413B-00	23 - 37
4LS-E1186-00	1 - 7	5YY-E465F-00	1 - 2	5YY-E7231-10	14 - 9	22P-F1510-00-0X	18 - 1		22 - 32		23 - 38
4LS-E1310-01	1 - 15	5YY-E4703-20	8 - 1	5YY-E7241-10	14 - 12	22P-F1510-00-1X	18 - 1	4LS-F3142-00	22 - 15	5YY-F4141-00	23 - 41
5YY-E1351-00	1 - 16	22P-E4758-00	8 - 2	5YY-E7251-10	14 - 7	22P-F1510-00-2X	18 - 1		22 - 33	4UU-F4181-01	23 - 2
5YY-E1400-20	2 - 1	5YY-E4803-00	8 - 15	5YY-E7258-00	14 - 14	22P-F1510-00-3X	18 - 1	5YY-F3144-10	22 - 13	5YY-F4182-00	23 - 3
4LS-E1500-02	2 - 7	5YY-E4844-00	8 - 13	5YY-E7402-10	14 - 6	5TS-F1518-00	18 - 3		22 - 31	5US-F4183-00	23 - 4
4LS-E1603-00	2 - 6	5YY-E4849-00	8 - 12	5YY-E7410-10	14 - 1	5TS-F1541-00	38 - 4	5YY-F3145-10	22 - 4	35B-F4188-00	23 - 36
4LS-E1605-00	2 - 6	5YY-E4872-00	8 - 11	4LS-E7456-00	14 - 21	5C9-F1568-S0	23 - 42		22 - 22	5YY-F4216-20	23 - 30
4LS-E1607-00	2 - 6	5YY-E4881-00	8 - 16	4LS-E7471-00	14 - 4	5YY-F1611-00	18 - 4	36L-F3147-00	22 - 18	22P-F4244-00	23 - 39
4LS-E1631-01	2 - 3	5YY-E4882-00	8 - 18	4LS-E8101-01	16 - 7	22P-F1668-00	20 - 11		22 - 36	22P-F4244-10	23 - 39
4LS-E1636-00	2 - 3	5YY-E4901-02	7 - 1	22P-E8110-00	16 - 9	5C9-F1685-00	18 - 10	36L-F3152-10	22 - 10	22P-F4244-20	23 - 39
4LS-E1638-00	2 - 3	5YY-E4987-00	8 - 20	5VA-E8113-00	16 - 10	5YY-F1691-00	18 - 5		22 - 28	22P-F4244-30	23 - 39
4LS-E2111-10	3 - 1	5YY-E5111-10	9 - 3	4LS-E8140-01	16 - 1	22P-F1711-01-0X	19 - 1	4LS-F3153-00	22 - 5	22P-F4245-00	23 - 40
5YY-E2113-00	3 - 5	5YY-E5191-00	10 - 12	4LS-E8185-00	15 - 2	22P-F1711-01-1X	19 - 1		22 - 23	22P-F4245-10	23 - 40
4LS-E2116-00	3 - 4	4LS-E5362-00	10 - 19	4LS-E8337-00	16 - 2	22P-F1721-00-0X	19 - 2	36L-F3157-00	22 - 11	22P-F4245-20	23 - 40
4LS-E2117-00	3 - 7	5YY-E5411-20	10 - 2	4LS-E8511-00	15 - 5	22P-F1721-00-1X	19 - 2		22 - 29	22P-F4245-30	23 - 40

INDICE NUMERICO
NUMERICAL INDEX

CODIGO N° PART NO.	REF. N°	CODIGO N° PART NO.	REF. N°	CODIGO N° PART NO.	REF. N°	CODIGO N° PART NO.	REF. N°	CODIGO N° PART NO.	REF. N°	CODIGO N° PART NO.	REF. N°
5YY-F4311-00	23 - 20	5US-F5190-10	25 - 10	5YY-F742L-00	30 - 30	4LS-H2540-00	39 - 4	5YY-H4723-10	36 - 5	90109-08831	27 - 32
4LS-F4500-02	23 - 7	5US-F5321-10	27 - 8	5TS-F7431-11	30 - 25	22P-H2590-00	38 - 10	5US-H5110-00	18 - 13	90109-100G0	26 - 13
4UU-F4512-00	23 - 13	5YY-F5338-10	27 - 1	5TS-F7433-00	30 - 26	5YY-H2590-50	38 - 10	5YY-H5540-10	39 - 6	90110-06805	31 - 4
4UU-F4515-00	23 - 12	36L-F533A-10	27 - 16		30 - 32	5YY-H2911-00	37 - 14	5YY-H5542-00	39 - 8	90110-06806	31 - 5
4UU-F4521-00	23 - 10	5YY-F5351-10	27 - 12	5TS-F743H-00	30 - 15	5YY-H2917-00	39 - 21	5YY-H5546-00	39 - 7	90110-06810	4 - 4
4UU-F4523-00	23 - 16	35B-F5355-00	27 - 13	5TS-F7441-11	30 - 31	5YY-H3310-20	33 - 1	5YY-H5701-00	38 - 18	90110-06850	1 - 14
4UU-F4524-00	23 - 15	36L-F5364-00	27 - 7	22P-F8100-00	17 - 15	36L-H3311-00	33 - 2	5YY-H5750-00	34 - 9	90110-08808	12 - 11
4UU-F4534-00	23 - 8	5TS-F5366-00	27 - 17	5TS-F811G-00	17 - 16		33 - 5	5TS-H5753-20	38 - 19	90111-06083	35 - 23
4UU-F4565-00	23 - 11	5VA-F5371-00	27 - 28	22P-F8351-00-33	35 - 1	36L-H3311-20	36 - 6	5US-W0016-00	26 - 10	90111-08057	26 - 2
22P-F471K-01-33	24 - 5	5YY-F5381-00	27 - 36	22P-F8351-00-P0	35 - 1	5YY-H3318-10	33 - 7	5US-W0041-00	29 - 5	90119-05020	35 - 20
22P-F471K-01-P0	24 - 5	22P-F5387-00	27 - 21	22P-F8351-00-P1	35 - 1	5YY-H3320-20	33 - 4	5US-W0045-00	26 - 7		35 - 21
22P-F471K-01-P1	24 - 5	22P-F5389-00	27 - 42	22P-F8351-00-WG	35 - 1	5YY-H3350-00	39 - 11	5US-W0047-00	26 - 4	90119-05801	13 - 12
22P-F471K-01-WG	24 - 5	22P-F539F-00	27 - 43	5YY-F8365-00	35 - 14	5KA-H3351-00	39 - 12	5US-W0048-00	26 - 6	90119-06044	39 - 17
4UU-F4724-00	20 - 8	4JF-F5412-10	27 - 24	22P-F836B-00	35 - 17	5YY-H3371-10	39 - 14	5US-W0053-00	26 - 12	90119-06108	6 - 20
22P-F472K-01-33	24 - 6	22P-F5445-00	27 - 22	22P-F8377-00-33	35 - 2	5YY-H3376-00	39 - 16	5US-W0068-00	26 - 11		18 - 9
22P-F472K-01-P0	24 - 6	5US-F5744-00	26 - 8	22P-F8377-00-P0	35 - 2	5YY-H3500-10	34 - 1	5YY-WE111-10	1 - 1		18 - 11
22P-F472K-01-P1	24 - 6	5YY-F580U-00	26 - 3	22P-F8377-00-P1	35 - 2	5HH-H350W-00	34 - 3	5YY-WE141-00	7 - 8	90119-06114	19 - 13
22P-F472K-01-WG	24 - 6	5US-F5827-00	26 - 9	22P-F8377-00-WG	35 - 2	5HH-H3517-00	34 - 5	5YY-WE142-00	7 - 5	90119-06202	20 - 10
22P-F4730-00	24 - 1	5YY-F582U-00	26 - 1	5YY-F8381-30	35 - 3	5HH-H3518-00	34 - 4	5TS-WE445-10	6 - 13	90123-08046	37 - 1
22P-F4741-00	8 - 7	5YY-F583T-10	29 - 4	22P-F8391-00	35 - 24	5TS-H3519-00	34 - 2	5YY-WE512-30	9 - 4	90149-04242	23 - 14
	24 - 2	4UU-F5846-00	25 - 7	22P-F8391-10	35 - 24	5YY-H353E-10	34 - 6	5TS-WF461-01	23 - 19	90149-06002	38 - 8
22P-F4756-00-33	24 - 7	5YY-F5867-00	29 - 9	22P-F8391-20	35 - 24	5YY-H353F-10	34 - 7	5YY-WF533-00	27 - 9	90149-06108	23 - 17
22P-F4756-00-P0	24 - 7	5YY-F5872-00	29 - 1	22P-F8391-30	35 - 24	5YY-H3550-30	34 - 12	5YY-WH331-20	33 - 3	90150-05023	35 - 4
22P-F4756-00-P1	24 - 7	5YY-F5875-00	29 - 11	22P-F8392-00	35 - 25	5YY-H3559-00	35 - 18	5YY-WH332-20	33 - 6	90151-06801	15 - 4
22P-F4756-00-WG	24 - 7	5YY-F5876-00	29 - 12	22P-F8392-10	35 - 25	5YY-H3559-10	34 - 10	5YY-WH585-00	7 - 10	90154-05051	35 - 13
5YY-F4773-10-P0	24 - 10	5US-F5977-00	26 - 5	22P-F8392-20	35 - 25	5YY-H3570-10	34 - 8	90101-06278	27 - 14	90155-06800	5 - 9
22P-F477V-00	24 - 13	22P-F6111-00	28 - 1	22P-F8392-30	35 - 25	4LS-H3912-00	37 - 15	90101-08590	4 - 7	90157-06802	14 - 5
22P-F477V-10	24 - 13	5YY-F6131-10	21 - 21	5YY-H1400-40	31 - 1	5YY-H3922-00	37 - 3	90101-10034	30 - 22	90159-06067	19 - 11
22P-F477V-20	24 - 13	5YY-F6132-00	21 - 22	5YY-H1410-00	31 - 3	36L-H3936-00	37 - 20	90105-05361	38 - 20		24 - 8
22P-F477V-30	24 - 13	4UU-F6240-00	28 - 9	5YY-H1450-40	31 - 2	5TS-H3936-01	38 - 12	90105-05800	32 - 6	90160-05807	23 - 26
22P-F477W-00	24 - 14	4UU-F6241-00	28 - 8	5YY-H1800-00	32 - 1	4TL-H3941-00	37 - 10	90105-06812	4 - 12	90170-05302	3 - 10
22P-F477W-10	24 - 14	4UU-F6242-00	28 - 10	5US-H1801-00	32 - 2	36L-H3945-10	37 - 16	90105-06855	9 - 11	90170-12060	13 - 18
22P-F477W-20	24 - 14	5YY-F6280-00	28 - 11	5YY-H183G-00	32 - 5	5YY-H3969-10	37 - 9	90105-06856	9 - 10	90170-22187	19 - 8
22P-F477W-30	24 - 14	5YY-F6290-00	28 - 12	5US-H1847-00	32 - 7	5YY-H3975-00	37 - 7	90105-06858	9 - 9	90171-14020	25 - 14
22P-F477X-00	24 - 15	5YY-F6311-30	28 - 2	5US-H1940-00	38 - 13	5YY-H3980-10	37 - 6	90105-06859	29 - 10	90171-14037	27 - 40
22P-F477X-10	24 - 15	5YY-F6331-00	28 - 7	5YY-H1950-00	38 - 15	5YY-H4196-20	35 - 7	90105-06868	32 - 8	90176-06019	36 - 10
22P-F477X-20	24 - 15	5YY-F6335-10	28 - 5	5YY-H1952-00	39 - 13	22P-H4310-00	35 - 6	90105-08007	17 - 12	90176-10073	20 - 14
22P-F477X-30	24 - 15	4TL-F6372-00	28 - 6	5YY-H1960-10	38 - 5	5YY-H4312-10	35 - 8	90105-08147	17 - 10	90179-05523	35 - 5
22P-F477Y-00	24 - 16	5US-F6393-00	28 - 3	5YY-H2109-00	30 - 14	5YY-H4314-20	35 - 10	90105-08198	17 - 9	90179-06411	30 - 12
22P-F477Y-10	24 - 16	22P-F7111-00	30 - 1	3AY-H2110-00	38 - 1	5YY-H4345-10	35 - 15	90105-08201	17 - 5	90179-08148	37 - 2
22P-F477Y-20	24 - 16	22P-F7112-00	30 - 2	5YY-H2115-00	38 - 16	5YY-H4347-10	35 - 9	90105-08202	17 - 13	90179-08639	27 - 25
22P-F477Y-30	24 - 16	5C9-F7115-00	30 - 3	5YY-H2116-00	38 - 17	5YY-H4521-20	36 - 2	90105-08886	1 - 9	90179-12800	11 - 18
5YY-F4796-11	24 - 11	5YY-F7211-10	30 - 5	5YY-H2131-10	38 - 3	5YY-H4527-00	35 - 16	90105-10006	21 - 12		13 - 4
5YY-F511X-00	25 - 12	22P-F7231-00	30 - 7	36L-H2151-V0	38 - 11	5TS-H4553-00	36 - 7	90105-10778	20 - 15	90179-25033	21 - 7
5US-F5135-10	25 - 11	22P-F7311-00	30 - 20	5YY-H2310-00	39 - 1	5TS-H4554-00	36 - 8	90109-06806	16 - 3	90183-05814	35 - 12
4UU-F5149-00	25 - 6	22P-F7411-00	30 - 13	5YY-H2370-00	39 - 3	5YY-H4703-00	36 - 9	90109-06859	37 - 4	90185-06802	37 - 5
5YY-F5168-10	25 - 1	5YY-F7413-00	30 - 17	5TS-H2501-11	38 - 7	5YY-H4710-20	36 - 1	90109-08063	27 - 29	90185-10091	30 - 23
5YY-F5181-00	25 - 13	5YY-F741L-00	30 - 24	5TS-H2530-01	38 - 9	36L-H4714-00	36 - 4	90109-08201	27 - 23	90201-05016	8 - 6

INDICE NUMERICO
NUMERICAL INDEX

CODIGO Nº PART NO.	REF. Nº	CODIGO Nº PART NO.	REF. Nº	CODIGO Nº PART NO.	REF. Nº	CODIGO Nº PART NO.	REF. Nº	CODIGO Nº PART NO.	REF. Nº	CODIGO Nº PART NO.	REF. Nº
90201-05725	18 - 7	90387-15808	27 - 37	91830-21014	10 - 1	93608-30839	9 - 6	95817-08025	30 - 18		
90201-06057	24 - 4	90401-10818	29 - 2		10 - 4		16 - 8	95817-10080	17 - 3		
90201-07641	5 - 4	90430-06817	4 - 16	92017-06014	24 - 3	93615-12840	12 - 10	95822-06020	18 - 2		
90201-07800	5 - 7	90430-10148	39 - 5	92907-06200	30 - 9	93822-14800	14 - 20	95827-06012	21 - 18		
90201-08060	30 - 38	90430-12227	5 - 11		37 - 11	94127-18830	25 - 8		29 - 13		
90201-08326	4 - 6	90445-08825	38 - 2	92907-08100	27 - 34	94130-18824	27 - 26	95827-06016	21 - 19		
90201-08569	23 - 5	90450-44046	6 - 4	92907-14200	25 - 15	94227-18810	25 - 9	95827-08040	21 - 11		
90201-08609	1 - 10	90464-10829	18 - 12	9290N-05200	39 - 10		27 - 27	97007-05025	39 - 2		
90201-08834	37 - 19	90465-09800	9 - 8	9290N-06200	13 - 15	94568-A0090	4 - 8	97027-06020	16 - 11		
90201-101J1	30 - 40	90467-08801	8 - 21		27 - 44	94568-A3119	27 - 46	97027-08016	23 - 6		
90201-106F2	20 - 13		8 - 24	93101-10838	10 - 21	94668-81001	27 - 47	9750M-06425	37 - 18		
90201-10815	29 - 3	90467-09006	23 - 21	93102-12875	16 - 4	94700-00834	1 - 11	97607-06214	38 - 6		
90201-122H1	2 - 10	90467-13802	8 - 22	93102-12877	13 - 23	95027-06010	14 - 22	97607-06225	6 - 14		
	13 - 3	90467-13858	9 - 2	93102-20876	14 - 18	95027-06016	4 - 15	98507-03008	23 - 9		
	20 - 5	90467-15012	6 - 16	93104-22805	27 - 5	95027-06020	1 - 6	98507-04008	7 - 24		
90201-14740	20 - 6	90467-16195	8 - 19	93105-45801	25 - 5	95027-06035	10 - 5	98507-04010	7 - 28		
90201-15023	27 - 39		8 - 23	93106-22820	25 - 4		10 - 17	98507-05008	7 - 2		
90201-15809	11 - 15	90467-16805	8 - 17	93106-26801	27 - 20	95027-06045	10 - 6	98507-05010	28 - 4		
90201-177G4	14 - 15	90468-12007	27 - 31	93109-20821	11 - 19		10 - 18	98507-05035	37 - 13		
90201-178D3	11 - 9		27 - 35	93210-108B1	4 - 2	95027-06055	10 - 7	98507-06008	37 - 12		
90201-20272	14 - 16	90468-26048	11 - 3	93210-14806	34 - 13	95027-08030	21 - 15	98507-06918	37 - 8		
90201-202L3	11 - 4	90480-01870	24 - 9	93210-14899	10 - 9	95307-06600	27 - 15	9850N-05010	39 - 9		
90201-225A4	19 - 10	90480-13426	19 - 3	93210-19809	10 - 20	95307-08600	27 - 33	9850N-05012	18 - 6		
90201-25290	12 - 6		23 - 27	93210-25804	32 - 4	95307-08700	27 - 30	9850N-06012	12 - 4		
90202-05193	23 - 18	90480-13861	23 - 43	93210-30611	6 - 2	9530N-05600	18 - 8	9850N-06034	36 - 3		
90202-05807	8 - 5	90480-24186	19 - 9	93210-328A4	10 - 11	9530N-06600	13 - 16	98706-04012	29 - 8		
90202-09800	23 - 32	90501-04833	12 - 8	93210-42807	27 - 6		27 - 45	98907-06010	23 - 29		
90202-20800	30 - 27	90501-10245	30 - 10	93210-44889	1 - 8	95702-06500	38 - 14	98907-06016	10 - 14		
	30 - 33	90501-12081	11 - 13	93210-56803	32 - 3	95702-08500	17 - 11	98980-06012	8 - 3		
90202-26142	21 - 9	90501-216A6	13 - 11	93210-57897	1 - 17	95702-12500	20 - 4	99001-05600	5 - 3		
90206-06090	8 - 4	90506-12001	27 - 10	93210-79800	1 - 5	95707-05500	18 - 14	99001-10600	11 - 16		
90208-07052	5 - 5	90506-15001	27 - 11	93306-004Y0	27 - 19	95707-06300	37 - 17		16 - 6		
90209-10020	21 - 13	90506-29800	30 - 21	93306-201Y4	14 - 2	95707-06500	23 - 33	99009-17400	11 - 10		
90209-18208	14 - 10	90506-32800	30 - 4	93306-202Y0	25 - 3		34 - 11	99009-20500	13 - 24		
90215-12815	13 - 17	90508-14857	13 - 22		27 - 3	95707-08500	17 - 6	99244-00080	24 - 17		
90249-12008	30 - 11	90508-26667	11 - 6	93306-202Y1	27 - 4		17 - 14	99246-00080	24 - 17		
90252-27800	30 - 29	90508-32837	16 - 5	93306-202YD	2 - 8	95707-10500	17 - 4	99246-00100	19 - 14		
	30 - 35	90508-40809	30 - 6	93306-203X2	14 - 3	95707-12500	2 - 11		19 - 15		
90280-03017	2 - 9	90560-15136	27 - 2	93306-203X9	14 - 19	95807-06012	8 - 14	99830-21014	9 - 7		
90282-05001	13 - 2	90560-15293	25 - 2	93306-204Y6	14 - 17		8 - 25				
90340-12097	5 - 10	91317-06020	6 - 3	93306-205XU	2 - 2		35 - 22				
90340-14814	10 - 8		8 - 9	93410-22039	14 - 11		39 - 15				
90340-32808	10 - 10	91401-20012	30 - 8	93420-42801	27 - 18	95807-06014	30 - 16				
90387-058W5	35 - 19	91401-30030	25 - 16	93450-16812	2 - 5	95812-08025	30 - 37				
90387-061N6	23 - 31		27 - 41	93503-16807	13 - 19	95812-08035	30 - 36				
90387-066K1	6 - 21	91701-06038	30 - 28	93507-32819	11 - 14	95817-08016	30 - 19				
90387-10003	30 - 39		30 - 39	93602-20800	5 - 6	95817-08020	24 - 12				
90387-15806	27 - 38	91810-14804	1 - 13	93604-10011	15 - 3	95817-08025	8 - 10				