



**PARTS  
CATALOGUE  
CATALOGO  
DE REPUESTOS**

**FZ16** (45D3) COLOMBIA

---



1L45D-261S1

( )

FZ16  
CATALOGO DE REPUESTOS  
©2011 por Yamaha Motor Co., Ltd.  
1ª edición, mayo 2011  
Todos los derechos reservados.  
Toda reproducción o uso no autorizado  
sin el consentimiento escrito de  
Yamaha Motor Co., Ltd.  
quedan expresamente prohibidos  
Impreso en Japón.

FZ16  
PARTS CATALOGUE  
©2011 by Yamaha Motor Co., Ltd.  
1st edition, May 2011  
All rights reserved.  
Any reprinting or unauthorized use  
without the written permission of  
Yamaha Motor Co., Ltd.  
is expressly prohibited.  
Printed in Japan.

# PROLOGO

Este catálogo de repuestos corresponde a las piezas para el o los modelos que figuran en la página de portada. Al formular el pedido de repuestos, se ruega citar este catálogo y especificar correctamente el número y el nombre de las piezas.

1. Las modificaciones y agregados que se hayan realizado después de la edición de este Catálogo de Repuestos, serán anunciados en las Informaciones de Recambios. Es recomendable que se hagan las correcciones necesarias en el Catálogo de Repuestos de acuerdo con las Informaciones de Recambios.

2. Abreviaciones

En este. Catálogo de Repuestos se emplean las siguientes abreviaciones.

“UR” Usar el número de partes especificado

“UN” Usar la cantidad necesaria

“AP” Piezas sustitutivas

“LM” Fabricación local (Hay que pedir los repuestos en las cercanías)

“F#” N° de bastidor (N° aplicable a la máquina)

“O/S” Sobredimensionado

3. La cantidad de componentes para el montaje

- Los componentes, suministrados como conjunto, se describen con un punto (.) que precede al nombre del parte como se indica a continuación.
- La numeración que aparece a la derecha de cada descripción indica la cantidad de partes por cada unidad de conjunto.

CODIGO N°	DESCRIPCION	CANT.	OBSERVACIONES
2F5-83310-60	ENSAMBLAJE DE LA LUZ	2	
115-83311-60	.BOMBILLA (6V-18W)	1	

4. Los colores de los componentes se indican como sigue en la columna de “OBSERVACIONES”.

CODIGO N°	DESCRIPCION	CANT.	OBSERVACIONES
2N4-24110-00-X5	COMP. DEL TANQUE	2	MXR
3J1-24240-10	.GRAFICO, DEL TANQUE	1	PARA MXR

5. Debe tenerse en cuenta que las ilustraciones sirven como guía para la búsqueda de los números de partes y no deben usarse para el montaje. Durante el montaje, se recomienda usar el manual de taller correspondiente.

6. EL asterisco (\*) antes del número de referencia indica los elementos modificados después de la primera edición.

# FOREWORD

This Parts Catalogue is related to the parts for the model(s) on the cover page. When you are ordering replacement parts, please refer to this Parts Catalogue and quote both part numbers and part names correctly.

1. Modifications or additions which have been made after the issue of the Parts Catalogue will be announced in the Parts News.

It is advisable that you make the necessary corrections to the Parts Catalogue according to the Parts News.

2. Abbreviations

The following abbreviations are used in this Parts Catalogue.

“UR” Use specified parts number.

“UN” Use as many as needed.

“AP” Alternate Parts

“LM” Locally Made (Parts need to be ordered locally)

“F#” Frame No. (Applicable machine No.)

“O/S” Over Size

3. The number of components for assembly

- Parts, which are to be supplied in an assembly, are listed with a dot (.) in front of the part name as shown below.
- The numeral appearing to the right of each component part indicates the quantity of parts for each assembly unit.

PART NO.	DESCRIPTION	Q'TY	REMARKS
2F5-83310-60	FRONT FLASHER LIGHT ASSY	2	
115-83311-60	.BULB (6V-18W)	1	

4. Applicable colours of graphics are represented in the “REMARKS” as shown below.

PART NO.	DESCRIPTION	Q'TY	REMARKS
2N4-24110-00-X5	FUEL TANK COMP.	2	MXR
3J1-24240-10	.GRAPHIC, FUEL TANK	1	FOR MXR

5. Note that the illustrations for reference in finding parts numbers are not to be used for assembling. When assembling, please use the applicable service manual.

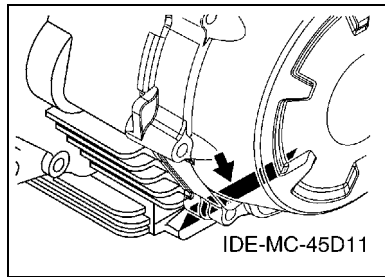
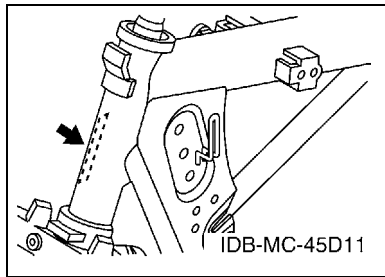
6. The asterisk (\*) before a reference number indicates modified items after the first edition.

# PROLOGO

## 7. Números de serie

Nº de Serie del bastidor

Nº de Serie del motor



## 8. Códigos de color aplicables (El símbolo (\*) muestra el color de modelo.)

Abreviatura	Nombre de color	Código de color
BMC(*)	BLUE METALLIC C	0775
DRMK(*)	DEEP RED METALLIC K	0918
S8	SILVER 8	0895
YB(*)	YAMAHA BLACK	0033
YRC2(*)	YELLOWISH RED COCKTAIL 2	1161

## 9. Nº de serie inicial aplicable

Nº de Serie del bastidor

Nº de serie	Nombre de la columna de cantidades	Código de Modelo

Nº de Serie del motor

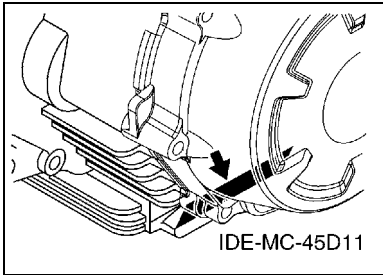
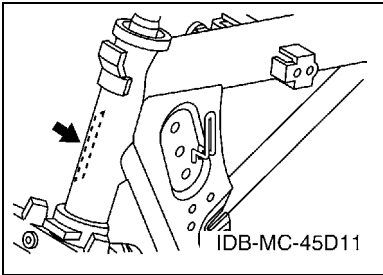
Nº de serie	Nombre de la columna de cantidades	Código de Modelo

# FOREWORD

7. Applicable Serial No.

Frame Serial No.

Engine Serial No.



8. Applicable Colour Code (The (\*) mark shows Model colour.)

Abbreviation	Colour Name	Colour Code
BMC(*)	BLUE METALLIC C	0775
DRMK(*)	DEEP RED METALLIC K	0918
S8	SILVER 8	0895
YB(*)	YAMAHA BLACK	0033
YRC2(*)	YELLOWISH RED COCKTAIL 2	1161

9. Applicable Starting Serial No.

Frame Serial No.

Serial No.	Name Of Q'ty Column	Model Code

Engine Serial No.

Serial No.	Name Of Q'ty Column	Model Code

# CONTENIDO

## MOTOR

CILINDRO .....	1
CIGUENAL & PISTON .....	3
VALVULA .....	5
ARBOL DE LEVAS & CADENA .....	6
BOMBA DE ACEITE .....	7
ADMISION .....	8
CARBURADOR .....	10
DESCARGA .....	12
CARTER .....	13
CUBIERTA DE CARTER 1 .....	14
EMBRAGUE DEL ARRANQUE .....	15
ARRANQUE .....	16
EMBRAGUE .....	17
TRANSMISION .....	19
LEVA DE CAMBIO & HORQUILLA .....	21
EJE DE CAMBIO & PEDAL .....	22

## SHASIS

CUADRO .....	23
GUARDABARRO .....	24
CUBIERTA LATERAL .....	25
BRAZO TRASERO & SUSPENSION .....	27
DIRECCION .....	28
HORQUILLA DELANTERA .....	29
DEPOSITO DE COMBUSTIBLE .....	31
DEPOSITO DE COMBUSTIBLE 2 .....	33
ASIENTO .....	35
RUEDA DELANTERA .....	36
CALIBRE FRENO DELANTERA .....	37
RUEDA TRASERA .....	38
MANILLAR & CABLE .....	40
CILINDRO MAESTRO DELANTERO .....	41
SOPORTE & APOYAPIE .....	42
SOPORTE & APOYAPIE 2 .....	44
GENERADOR .....	46
MOTOR DE ARRANQUE .....	47
LUZ DE DESTELLADOR .....	48
MEDIDOR .....	50
FARO DELANTERO .....	51
LUZ DE COLA .....	52
INTERRUPTOR DE MANILLAR&PALANC .....	53

EQUIPO ELECTRICO 1 .....	54
EQUIPO ELECTRICO 2 .....	55

## INDICE

INDICE NUMERICO .....	56
-----------------------	----

# CONTENTS

## ENGINE

CYLINDER .....	1
CRANKSHAFT & PISTON .....	3
VALVE .....	5
CAMSHAFT & CHAIN .....	6
OIL PUMP .....	7
INTAKE .....	8
CARBURETOR .....	10
EXHAUST .....	12
CRANKCASE .....	13
CRANKCASE COVER 1 .....	14
STARTER CLUTCH .....	15
STARTER .....	16
CLUTCH .....	17
TRANSMISSION .....	19
SHIFT CAM & FORK .....	21
SHIFT SHAFT .....	22

## CHASSIS

FRAME .....	23
FENDER .....	24
SIDE COVER .....	25
REAR ARM & SUSPENSION .....	27
STEERING .....	28
FRONT FORK .....	29
FUEL TANK .....	31
FUEL TANK 2 .....	33
SEAT .....	35
FRONT WHEEL .....	36
FRONT BRAKE CALIPER .....	37
REAR WHEEL .....	38
STEERING HANDLE & CABLE .....	40
FRONT MASTER CYLINDER .....	41
STAND & FOOTREST .....	42
STAND & FOOTREST 2 .....	44
GENERATOR .....	46
STARTING MOTOR .....	47
FLASHER LIGHT .....	48
METER .....	50
HEADLIGHT .....	51
TAILLIGHT .....	52
HANDLE SWITCH & LEVER .....	53

ELECTRICAL 1 .....	54
ELECTRICAL 2 .....	55

## INDEX

NUMERICAL INDEX .....	56
-----------------------	----



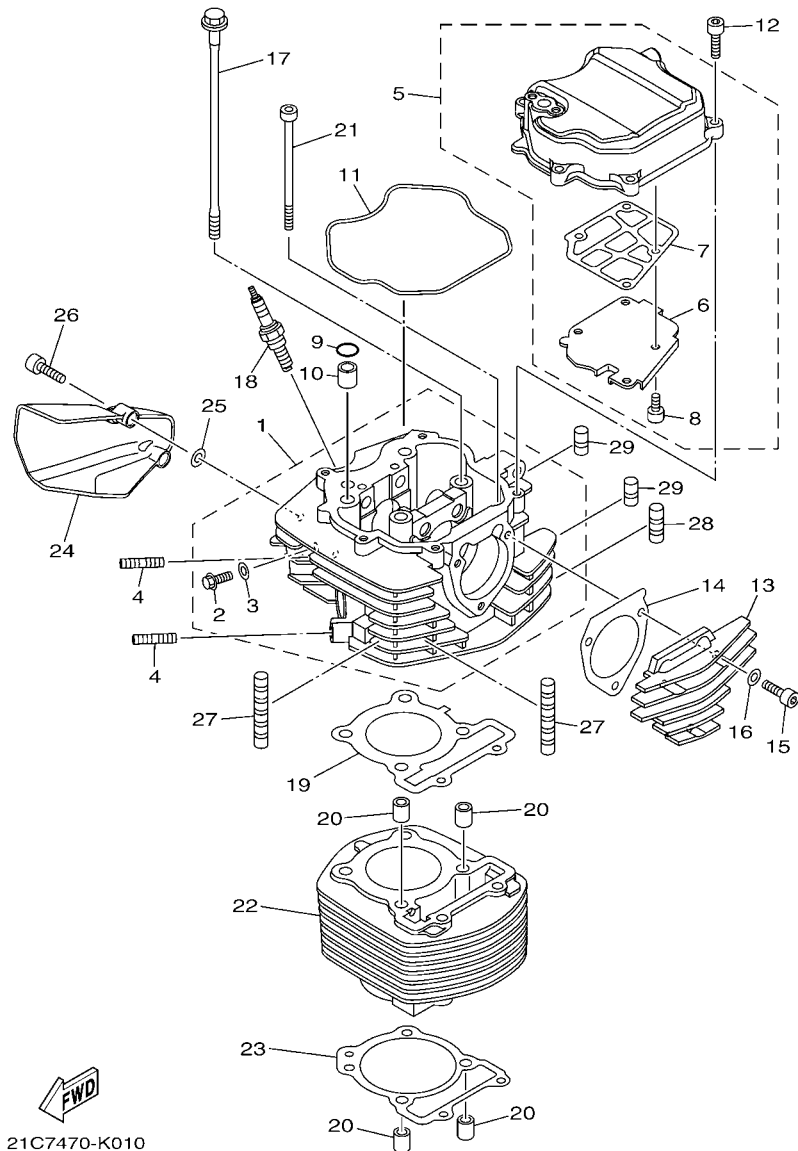


FIG. 1 CILINDRO

CYLINDER

REF. Nº	CODIGO Nº PART NO.	DESCRIPCION DESCRIPTION	45D3				OBSERVACIONES REMARKS
1	54B-E1111-00	CULATA CILINDRO 1 HEAD, CYLINDER 1	1				
2	95022-06012	.PERNO, DE BRIDA .BOLT, FLANGE	1				
3	90430-06014	.JUNTA .GASKET	1				
4	95617-08620	PERNO DE PUNTAL BOLT, STUD	2				
5	1ES-E1190-00	TAPA CULATA DE CILINDRO 1 COVER, CYLINDER HEAD 1	1				
6	54B-E1165-00	.PLACA RESPIRADERO .PLATE, BREATHER	1				
7	45P-E1169-00	.EMAPQ CBTA.DE RESP. .GASKET, BREATHER COVER	1				
8	91317-05010	.PERNO .BOLT	4				
9	93210-12800	ANILLO O O-RING	1				
10	93612-16254	PASADOR DE CLAVIJA PIN, DOWEL	1				
11	21C-E1193-00	EMPAQUE GASKET, HEAD COVER 1	1				
12	91317-06025	PERNO BOLT	5				
13	54B-E1186-00	CUBIERTA CULATA CIL.LAT.2 COVER, CYLINDER HEAD SIDE 2	1				
14	45P-E2435-00	EMPAQUE GASKET	1				
15	91317-06025	PERNO BOLT	3				
16	90430-06014	JUNTA GASKET	3				
17	90105-08197	TORNILLO BOLT, FLANGE	4				
18	94703-00885	BUJIA (NGK CPR8EA) PLUG, SPARK (NGK CPR8EA)	1				
19	54B-E1181-00	JUNTA, DE CULATA 1 GASKET, CYLINDER HEAD 1	1				
20	91810-14804	PASADOR DE CLAVIJA PIN, DOWEL	4				
21	90110-06304	TORNILLO ALLEN BOLT, HEXAGON SOCKET HEAD	2				
22	54B-E1310-00	CILINDRO CYLINDER	1				
23	21C-E1351-00	JUNTA, DE CILINDRO GASKET, CYLINDER	1				
24	21C-E2661-10	CONDUCTO DUCT	1				
25	90201-05015	ARANDELA PLANA WASHER, PLATE	2				
26	90110-06846	TORNILLO ALLEN BOLT, HEXAGON SOCKET HEAD	2				
27	21C-E1161-00	AMORTIGUADOR 1 ABSORBER 1	2				

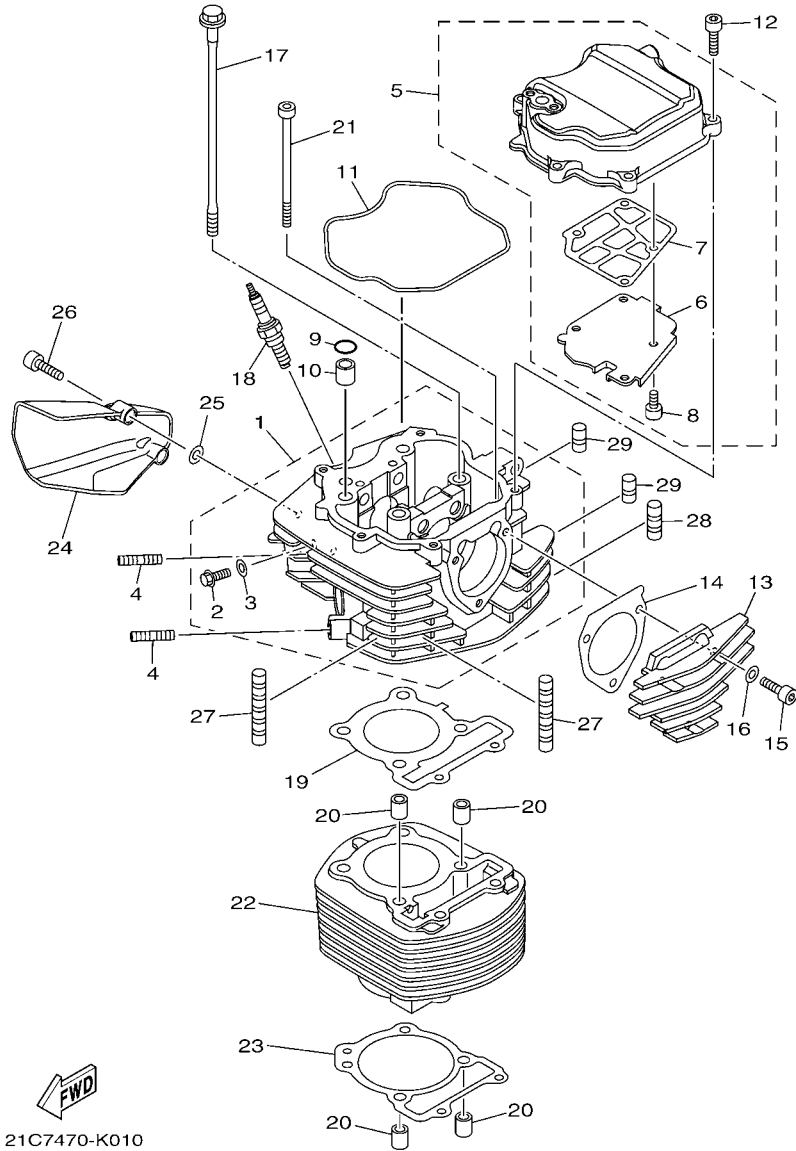
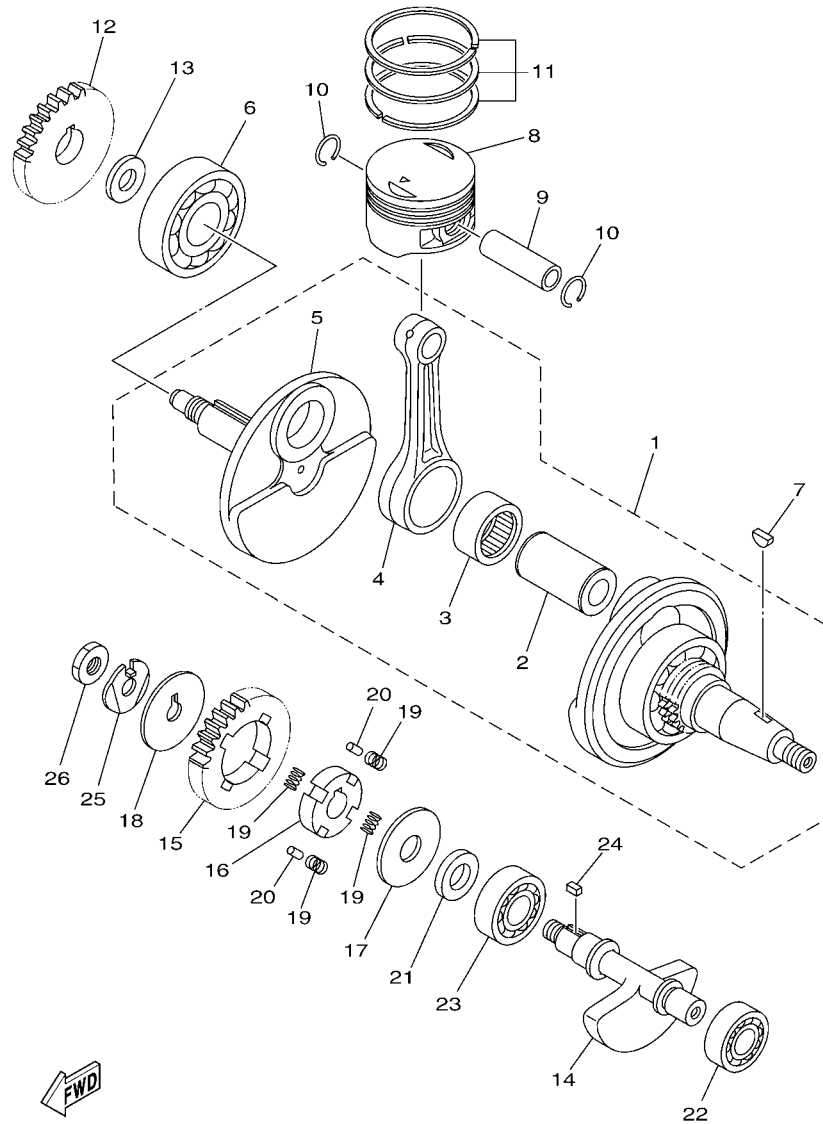


FIG. 1 CILINDRO

CYLINDER

REF. Nº	CODIGO Nº PART NO.	DESCRIPCION DESCRIPTION	45D3			OBSERVACIONES REMARKS
28	21C-E1161-10	AMORTIGUADOR 1 ABSORBER 1	1			
29	21C-E1161-20	AMORTIGUADOR 1 ABSORBER 1	2			



21C7470-K020

FIG. 2 CIGUENAL & PISTON

CRANKSHAFT & PISTON

REF. Nº	CODIGO Nº PART NO.	DESCRIPCION DESCRIPTION	45D3				OBSERVACIONES REMARKS
1	21C-E1400-09	CIGUENAL COMPLETO CRANKSHAFT ASSY	1				
2	21C-E1681-01	.PASADOR MANIVELA 1 .PIN, CRANK 1	1				
3	93310-628X0	.COJINETE DE RODILLOS .BEARING	1				
4	21C-E1651-00	.BIELA .ROD, CONNECTING	1				
5	21C-E1422-00	.MANIVELA 2 .CRANK 2	1				
6	93306-305YR	COJINETE BEARING	1				
7	90280-03017	CUNA WOODRUFF KEY, WOODRUFF	1				
8	21C-E1631-00	PISTON (NORMA) PISTON (STD)	1				
	21C-E1636-09	PISTON (0.50MM O/S) PISTON (0.50MM O/S)	1				AP AP
	21C-E1638-09	PISTON (1.00MM O/S) PISTON (1.00MM O/S)	1				AP AP
9	21C-E1633-00	PASADOR, PISTON PIN, PISTON	1				
10	93450-16812	SEGURO CIRCLIP	2				
11	21C-E1603-00	JUEGO DE ANILLOS (NORMA) PISTON RING SET (STD)	1				
	21C-E1605-00	JUEGO DE ANILLOS (0.50MM O/S) PISTON RING SET (0.50MM O/S)	1				AP AP
	21C-E1607-00	JUEGO DE ANILLOS (1.00MM O/S) PISTON RING SET (1.00MM O/S)	1				AP AP
12	54B-E1536-00	ENGRANAJE TRACCIÓN GEAR, DRIVE	1				
13	90387-20813	ESPACIADOR COLLAR	1				
14	54B-E1454-00	PESO 1 WEIGHT 1	1				
15	21C-E1531-00	ENGRANAJE CONTRAPESO GEAR, BALANCE WEIGHT	1				
16	21C-E1496-20	COPA TOPE BOSS, BUFFER	1				
17	90201-15022	ARANDELA PLANA WASHER, PLATE	1				
18	90214-10006	ARANDELA DE POSICION WASHER, CLAW	1				
19	54B-E1476-00	RESORTE SPRING	4				
20	21C-E3362-00	RODILLO ROLLER	2				
21	90387-155J0	ESPACIADOR COLLAR	1				
22	93306-252YG	COJINETE BEARING	1				
23	93306-253Y6	COJINETE BEARING	1				





21C1470-G030

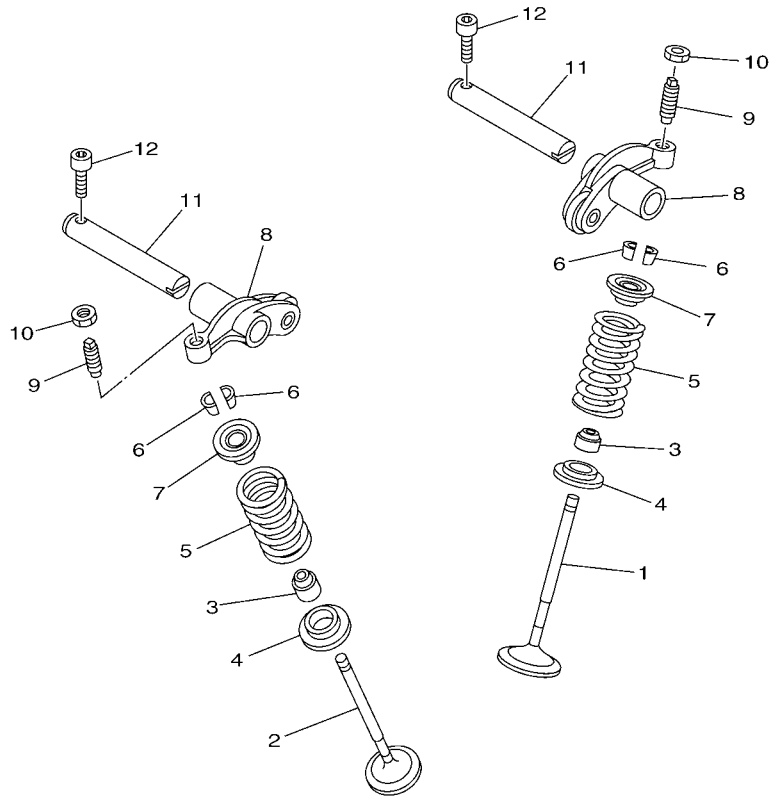
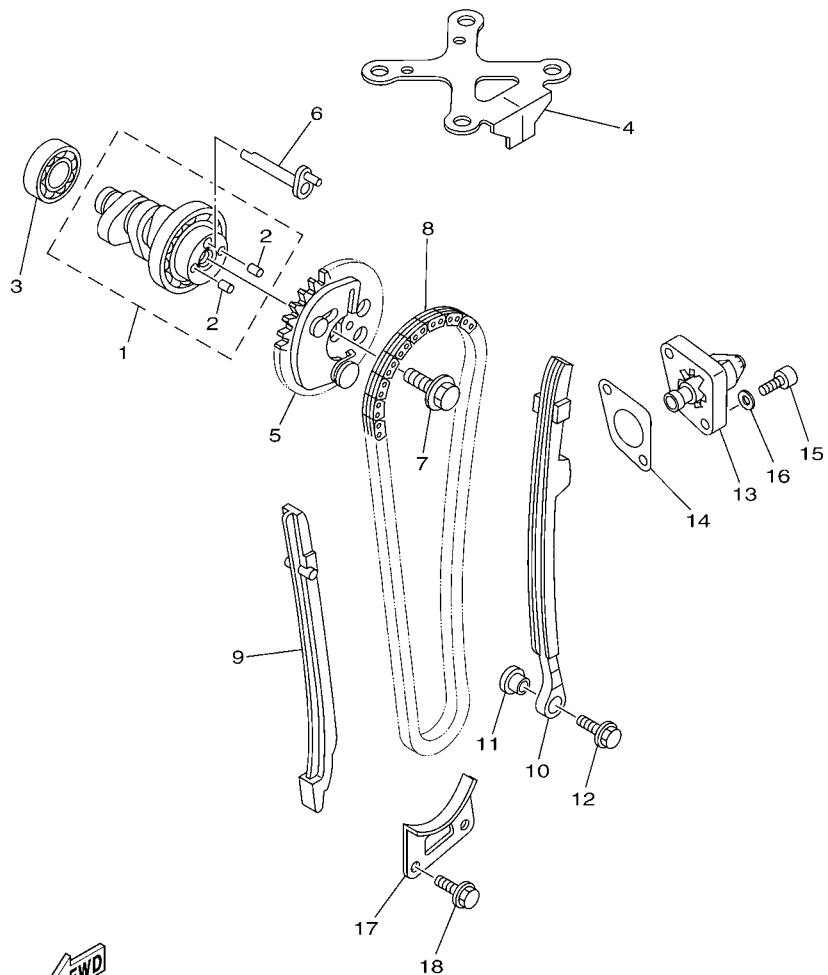


FIG. 3 VALVULA

VALVE

REF. N°	CODIGO N° PART NO.	DESCRIPCION DESCRIPTION	45D3				OBSERVACIONES REMARKS
1	54B-E2111-00	VALVULA DE ADMISION VALVE, INTAKE	1				
2	54B-E2121-00	VALVULA DE ESCAPE VALVE, EXHAUST	1				
3	21C-E2119-00	SELLO DE ACEITE VALVULA SEAL, VALVE STEM	2				
4	21C-E2126-00	ASIENTO RESORTE DE VALVULA2 SEAT, VALVE SPRING 2	2				
5	21C-E2113-00	RESORTE VALVULA INTERNA SPRING, VALVE INNER	2				
6	22F-12118-01	SEGURO DE VALVULA COTTER, VALVE	4				
7	21C-12117-00	RETEN RESORTE DE VALVULA RETAINER, VALVE SPRING	2				
8	21C-E2151-00	BRAZO DE BALANCIN DE VALVULA ARM, VALVE ROCKER	2				
9	21C-12159-00	TORNILLO DE AJUSTE DE VALVULA SCREW, VALVE ADJUSTING	2				
10	90170-06128	TUERCA NUT	2				
11	21C-E2156-00	EJE DE BALANCIN SHAFT, ROCKER 2	2				
12	91317-05016	PERNO BOLT	2				

FIG. 4 ARBOL DE LEVAS & CADENA CAMSHAFT & CHAIN

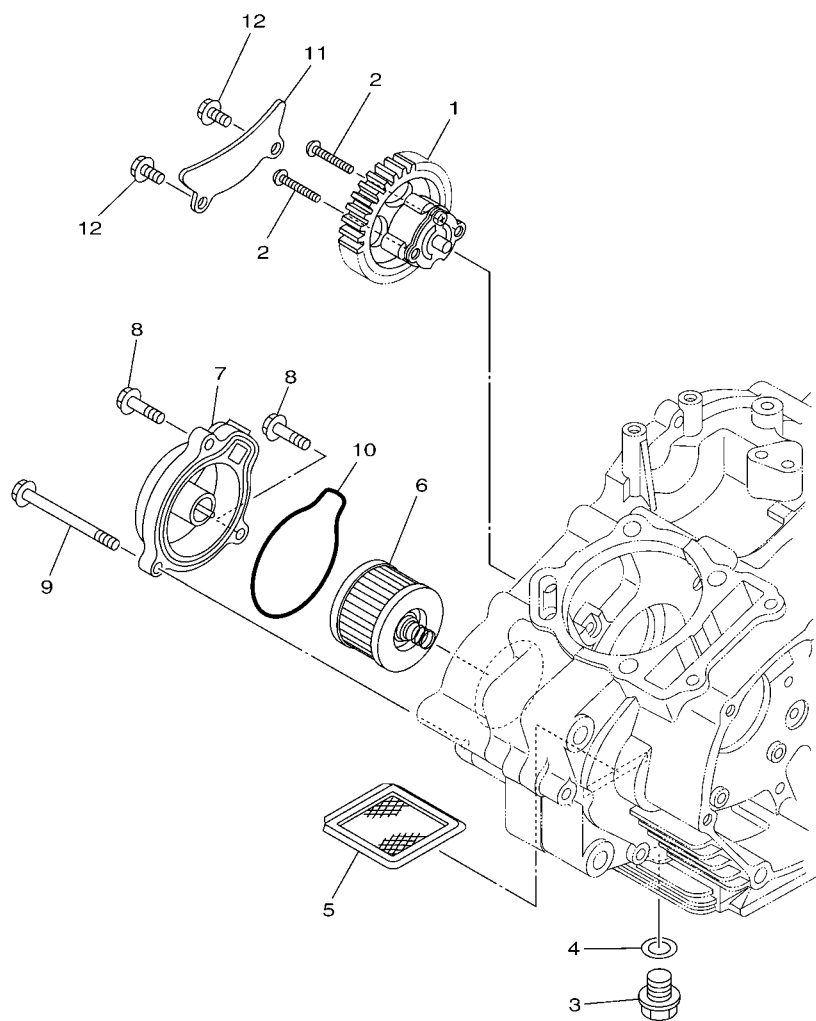


54B1470-J040

REF. Nº	CODIGO Nº PART NO.	DESCRIPCION DESCRIPTION	45D3				OBSERVACIONES REMARKS
1	21C-E2170-00	ARBOL DE LEVAS COMPLETO 1 CAMSHAFT ASSY 1	1				
2	93605-06800	.PASADOR DE CLAVIJA .PIN, DOWEL	2				
3	93306-002X2	COJINETE BEARING	1				
4	21C-E111F-00	PLACA PLATE	1				
5	54B-E2280-00	EQUIPO DE DESCOMPRESION DECOMPRESSION ASSY	1				
6	21C-E2288-00	LEVA DE DESCOMPRESION CAM, DECOMPRESSION	1				
7	90105-08196	TORNILLO BOLT, FLANGE	1				
8	94591-69096	CADENA CHAIN	1				
9	21C-E2231-00	TOPE DE GUIA 1 GUIDE, STOPPER 1	1				
10	21C-E2241-00	TOPE DE GUIA 2 GUIDE, STOPPER 2	1				
11	4LS-E5598-00	COLLAR COLLAR	1				
12	95802-06020	TORNILLO DE REBORDE BOLT, FLANGE	1				
13	21C-E2210-00	TENSOR CADENA DE LEVA TENSIONER ASSY, CAM CHAIN	1				
14	5MX-E2213-01	EMPAQUE DE CAJA TENSOR GASKET, TENSIONER CASE	1				
15	91317-06018	PERNO BOLT	2				
16	90201-06037	ARANDELA PLANA (T=1.0) WASHER, PLATE (T=1.0)	2				
17	21C-E2437-00	TOPE STOPPER	1				
18	95027-06016	PERNO, DE BRIDA BOLT, FLANGE	2				

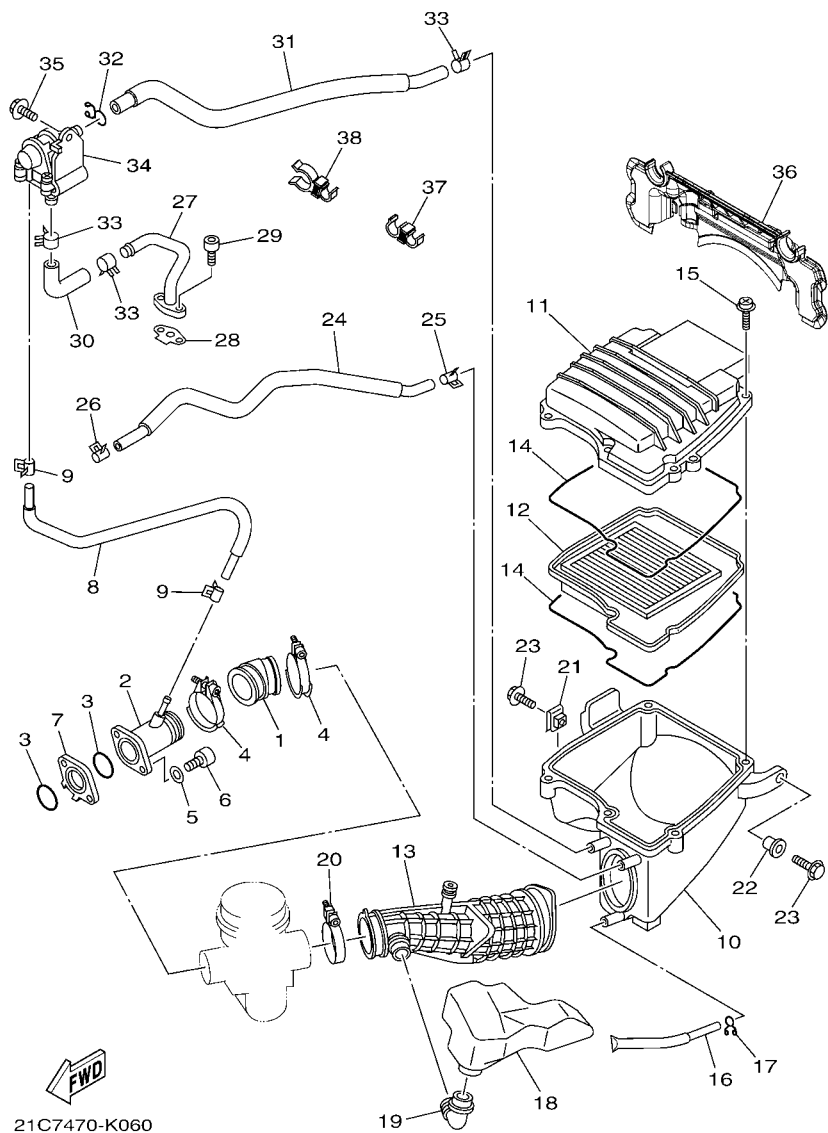
FIG. 5 BOMBA DE ACEITE

OIL PUMP



21C1470-G050

REF. Nº	CODIGO Nº PART NO.	DESCRIPCION DESCRIPTION	45D3			OBSERVACIONES REMARKS
1	54B-E3300-00	BOMBA DE ACEITE COMPLETA OIL PUMP ASSY	1			
2	90111-05808	TORNILLO BOLT, HEX. SOCKET BUTTON	2			
3	90340-12097	TORNILLO, DE DRENAJE PLUG, STRAIGHT SCREW	1			
4	90430-12227	JUNTA GASKET	1			
5	4LS-E3411-00	FILTRO DE ACEITE STRAINER, OIL	1			
6	21C-E3440-00	ELEMENTO FILTRO DE ACEITE ELEMENT ASSY, OIL CLEANER	1			
7	21C-E3447-00	TAPA DEL ELEMENTO COVER, OIL ELEMENT	1			
8	95027-06020	PERNO, DE BRIDA BOLT, FLANGE	2			
9	95027-06065	PERNO, DE BRIDA BOLT, FLANGE	1			
10	21C-E3449-00	JUNTA DE TAPA DE ELEMENTO GASKET, ELEMENT COVER	1			
11	21C-E3327-00	CUBIERTA ENGRANAJE DE BOMBA COVER, PUMP GEAR	1			
12	95022-06012	PERNO, DE BRIDA BOLT, FLANGE	2			



21C7470-K060

FIG. 6 ADMISION

INTAKE

REF. N°	CODIGO N° PART NO.	DESCRIPCION DESCRIPTION	45D3				OBSERVACIONES REMARKS
1	21C-E3586-01	TOBERA DE CARBURADOR 1 JOINT, CARBURETOR 1	1				
2	21C-E3536-01	TOBERA DE CARBURADOR JT. , CARBURETOR	1				
3	93210-30611	ANILLO O O-RING	2				
4	90450-44803	BRIDA, MANGUERA HOSE CLAMP ASSY	2				
5	92907-06600	ARANDELA WASHER, PLATE	2				
6	91317-06025	PERNO BOLT	2				
7	21C-E3595-00	TOBERA JOINT	1				
8	21C-E3542-00	MANGUERA, DE VACIO 1 HOSE, VACUUM SENSING 1	1				
9	90467-08808	PRESILLA CLIP	2				
10	21C-E4411-00	CAJA FILTRO DEL AIRE 1 CASE, AIR CLEANER 1	1				
11	21C-E4412-00	TAPA CAJA DEL FILTRO 1 CAP, CLEANER CASE 1	1				
12	21C-E4450-00	ELEMENTO COMP.FILTRO DE AIRE ELEMENT ASSY, AIR CLEANER	1				
13	21C-E4453-00	UNION DEL FILTRO DEL AIRE 1 JOINT, AIR CLEANER 1	1				
14	21C-E4452-00	SELLO SEAL	2				
15	97602-05320	TORNILLO CON RONDONA SCREW, PAN HEAD WITH WASHER	5				
16	21C-E443E-00	TUBO, DRENAJE PIPE, DRAIN	1				
17	90467-12800	PRESILLA CLIP	1				
18	21C-E4877-00	RESONATOR RESONATOR	1				
19	21C-E4485-00	TUBO DE UNION PIPE, JOINT	1				
20	90450-50802	BRIDA, MANGUERA HOSE CLAMP ASSY	1				
21	90183-06023	TUERCA DE RESORTE NUT, SPRING	1				
22	90387-06737	ESPACIADOR COLLAR	1				
23	95827-06016	TORNILLO BOLT, FLANGE	2				
24	21C-E1166-10	TUBO RESPIRADERO 1 PIPE, BREATHER 1	1				
25	90467-13816	PRESILLA CLIP	1				
26	90467-16805	PRESILLA CLIP	1				
27	21C-E4872-00	TUBO 2 PIPE 2	1				



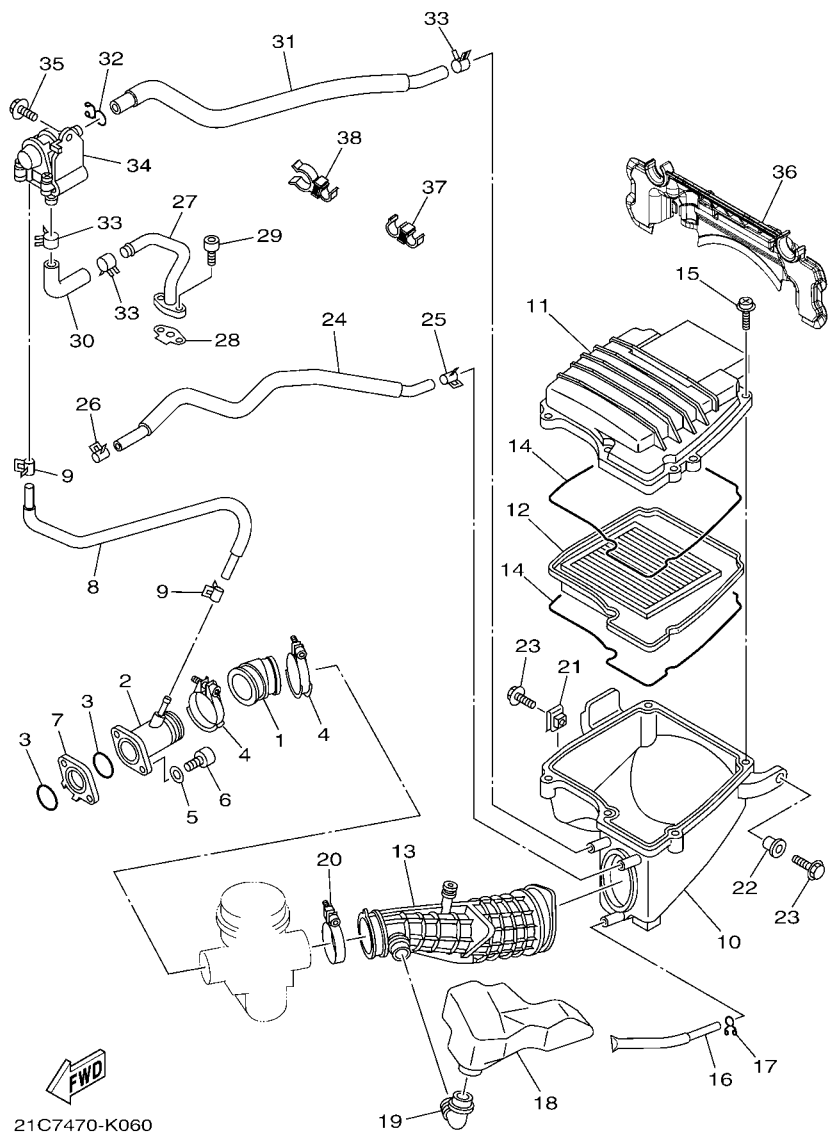


FIG. 6 ADMISION

INTAKE

REF. N°	CODIGO N° PART NO.	DESCRIPCION DESCRIPTION	45D3			OBSERVACIONES REMARKS
28	21C-E4815-00	EMPAQUE GASKET	1			
29	91317-06016	PERNO BOLT	2			
30	21C-E4881-00	TUBO 1 HOSE, BEND 1	1			
31	21C-E4882-00	TUBO 2 HOSE, BEND 2	1			
32	90467-15012	PRESILLA CLIP	1			
33	90467-16805	PRESILLA CLIP	3			
34	45P-E4803-10	VALVULA DE AIRE COMPLETA AIR INDUCTION SYSTEM ASSY	1			
35	95827-06012	TORNILLO BOLT, FLANGE	1			
36	21C-E449E-00	CUBIERTA DE FILTRO DE AIRE COVER, AIR CLEANER	1			
37	90464-11014	BRIDA CLAMP	1			
38	90464-16016	BRIDA CLAMP	1			

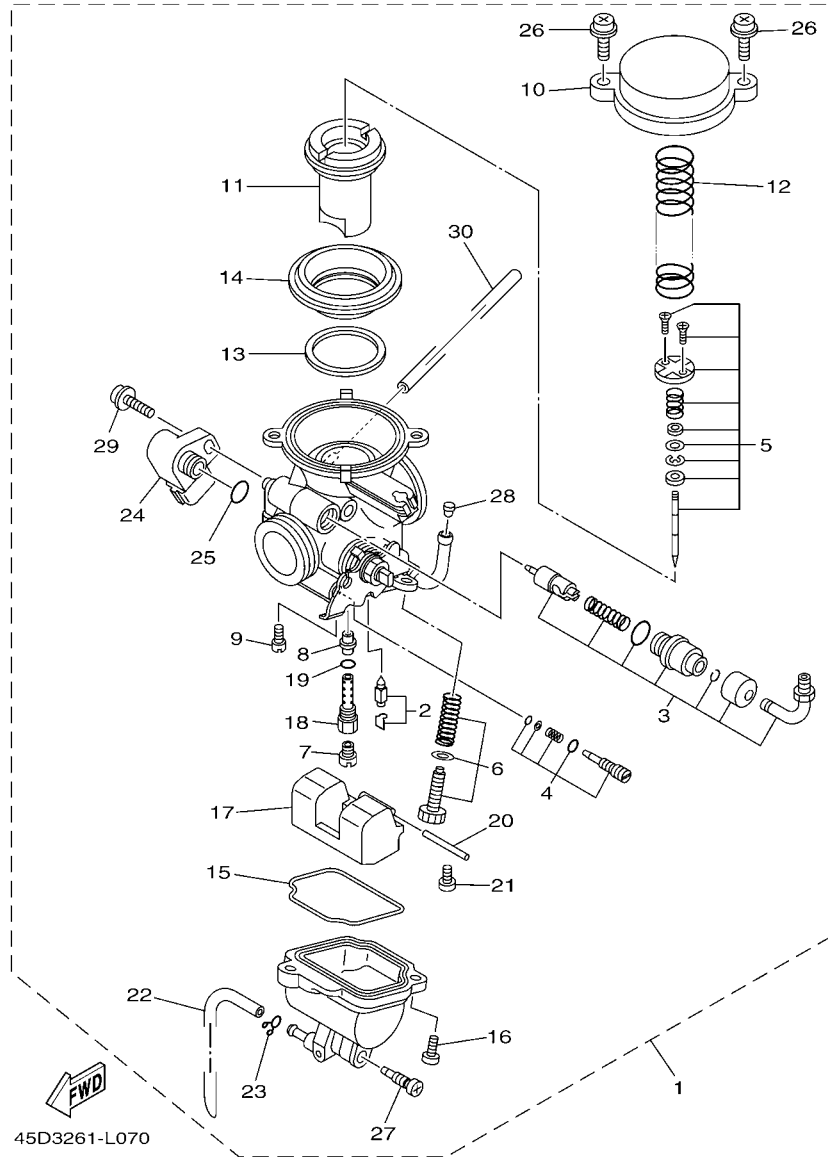


FIG. 7 CARBURADOR

CARBURETOR

REF. Nº	CODIGO Nº PART NO.	DESCRIPCION DESCRIPTION	45D3			OBSERVACIONES REMARKS
1	45D-14901-00	CARBURADOR COMPLETO 1 CARBURETOR ASSY 1	1			
2	5YY-14150-00	.AGUJA DEL CARB. .NEEDLE ASSY	1			
3	21C-1410A-00	.JUEGO DE ARRANQUE .STARTER SET	1			
4	21C-14105-00	.TORNILLO DE PILOTO .PILOT SCREW SET	1			
5	45D-1490J-00	.CJTO. AGUJA .NEEDLE SET	1			
6	21C-14103-00	.CJTO. TORNILLO DEL RALENTI .THROTTLE SCREW SET	1			
7	3G2-1414A-72	.INYECTOR, PRINCIPAL (#107.5) .JET, MAIN (#107.5)	1			
8	21C-1414M-41	.BOQUILLA PRINCIPAL .NOZZLE, MAIN	1			
9	1NT-14142-17	.SURTIDOR DE RALENTI (# 17.5) .JET, PILOT (#17.5)	1			
10	21C-14958-00	.CUBIERTA DE DIAFRAGMA .COVER, DIAPHRAGM	1			
11	21C-14340-00	.VALVULA COMPLETA .VALVE ASSY	1			
12	21C-14275-00	.RESORTE .SPRING	1			
13	5GH-14918-10	.ANILLO .RING	1			
14	21C-14545-00	.DIAFRAGMA .DIAPHRAGM	1			
15	21C-14147-00	.ANILLO O .O-RING	1			
16	98507-05012	.TORNILLO DE CABEZA PLANA .SCREW, PAN HEAD	2			
17	5HK-14985-00	.BOIA .FLOAT	1			
18	45D-1496A-00	.BOQUILLA PRINCIPAL .HOLDER, NEEDLE JET	1			
19	583-14561-00	.ANILLO O .O-RING	1			
20	353-14186-00	.PASADOR DE LA BOYA .PIN, FLOAT	1			
21	98507-04008	.TORNILLO DE CABEZA CON PLANA .SCREW, PAN HEAD	1			
22	21C-14987-00	.TUBO .HOSE	1			
23	22F-14139-00	.PRESILLA TUBO .CLIP, PIPE	1			
24	21C-85885-00	.TERMICA SENSORIO .THROTTLE SENSOR ASSY	1			
25	5YP-14561-00	.ANILLO O .O-RING	1			
26	4KM-14216-00	.TORNILLO .SCREW	2			
27	5LW-14191-00	.TORNILLO, DE DRENAJE .PLUG, DRAIN	1			

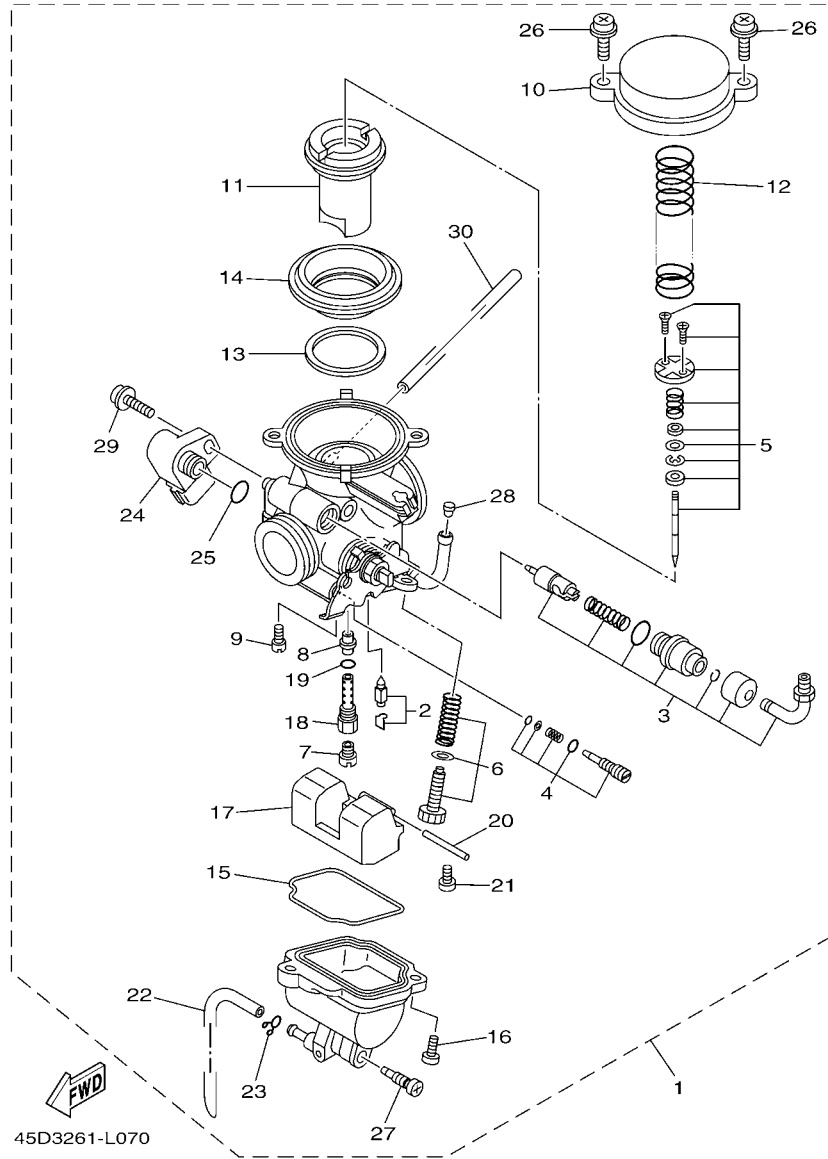


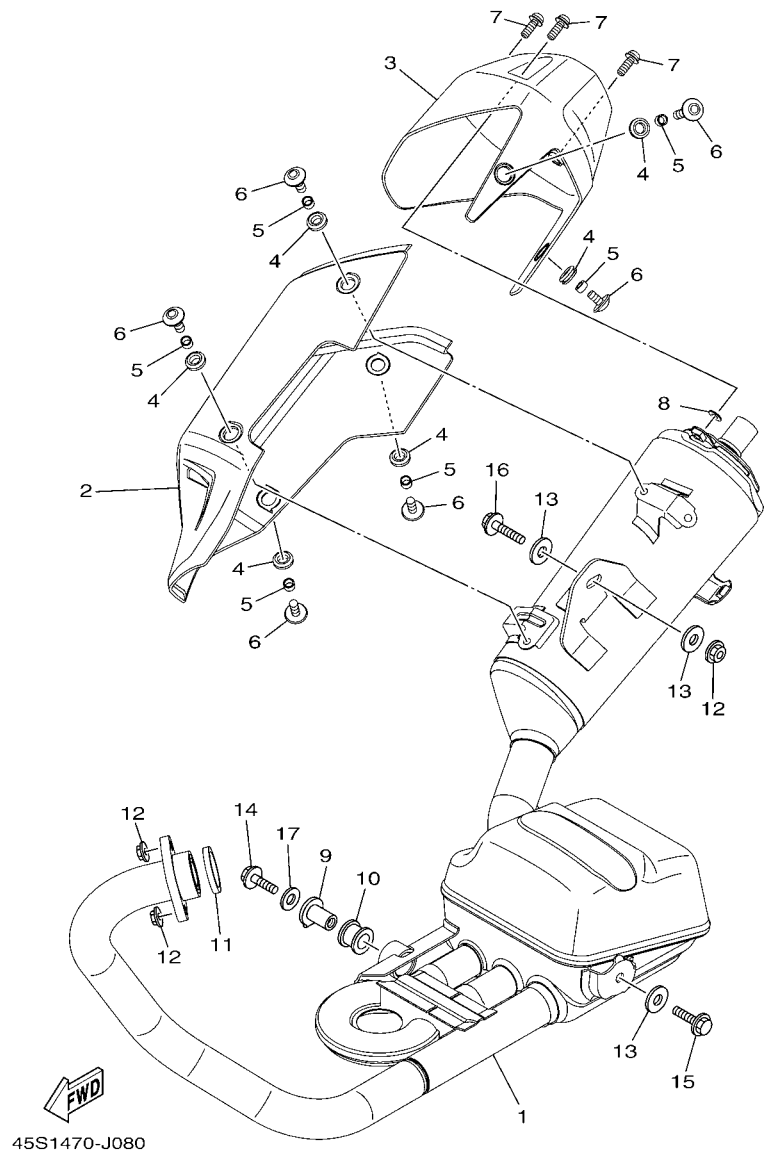
FIG. 7 CARBURADOR

CARBURETOR

REF. Nº	CODIGO Nº PART NO.	DESCRIPCION DESCRIPTION	45D3				OBSERVACIONES REMARKS
28	5LW-14994-00	.FILTRO .NET, FILTER	1				
29	21C-14216-00	.TORNILLO .SCREW	1				
30	21C-1410E-00	.TUBO .HOSE	1				

FIG. 8 DESCARGA

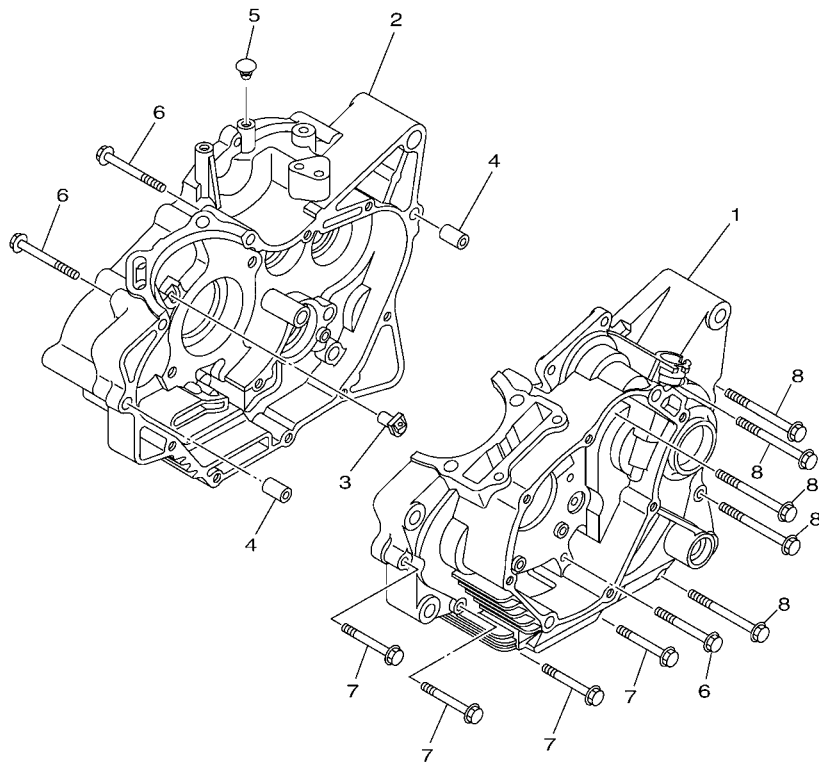
EXHAUST



REF. Nº	CODIGO Nº PART NO.	DESCRIPCION DESCRIPTION	45D3				OBSERVACIONES REMARKS
1	21C-E4703-10	SILENCIADOR COMPL. 1 MUFFLER COMP. 1	1				
2	21C-E4718-00	PROTECTOR DE SILENCIADOR 1 PROTECTOR, MUFFLER 1	1				
3	21C-E4799-01	TAPA CAP	1				
4	90480-12581	TAPON GROMMET	6				
5	90387-06023	ESPACIADOR COLLAR	6				
6	90111-06087	TORNILLO BOLT, HEX. SOCKET BUTTON	6				
7	90111-06807	TORNILLO BOLT, HEX. SOCKET BUTTON	3				
8	90202-05807	ARANDELA DE PLANA WASHER, PLATE	3				
9	21C-E4775-00	TUERCA NUT	1				
10	20P-E4747-00	AMORTIGUADOR DE SILENCIADOR DAMPER, MUFFLER	1				
11	21C-E4613-00	JUNTA, TUBO DE ESCAPE GASKET, EXHAUST PIPE	1				
12	95707-08500	TUERCA DE BRIDA NUT, FLANGE	3				
13	90201-08612	ARANDELA PLANA WASHER, PLATE	3				
14	95807-08025	TORNILLO BOLT, FLANGE	1				
15	95807-08035	TORNILLO BOLT, FLANGE	1				
16	95817-08040	TORNILLO BOLT, FLANGE	1				
17	90201-087F0	ARANDELA PLANA WASHER, PLATE	1				

**FIG. 9 CARTER**

**CRANKCASE**



REF. Nº	CODIGO Nº PART NO.	DESCRIPCION DESCRIPTION	46D3			OBSERVACIONES REMARKS
1	54B-E5111-00	CARTER MANIVELA 1 CRANKCASE 1	1			
2	54B-E5121-00	CARTER MANIVELA 2 CRANKCASE 2	1			
3	21C-E5155-00	BOQUILLA 3 NOZZLE 3	1			
4	91830-21014	PASADOR DE CLAVIJA PIN, DOWEL	2			
5	90338-05801	TAPON PLUG	1			
6	95027-06055	PERNO, DE BRIDA BOLT, FLANGE	3			
7	95027-06045	PERNO, DE BRIDA BOLT, FLANGE	4			
8	95027-06070	PERNO, DE BRIDA BOLT, FLANGE	5			
<hr/>						
<hr/>						
<hr/>						
<hr/>						
<hr/>						
<hr/>						

  
54B2470-J090

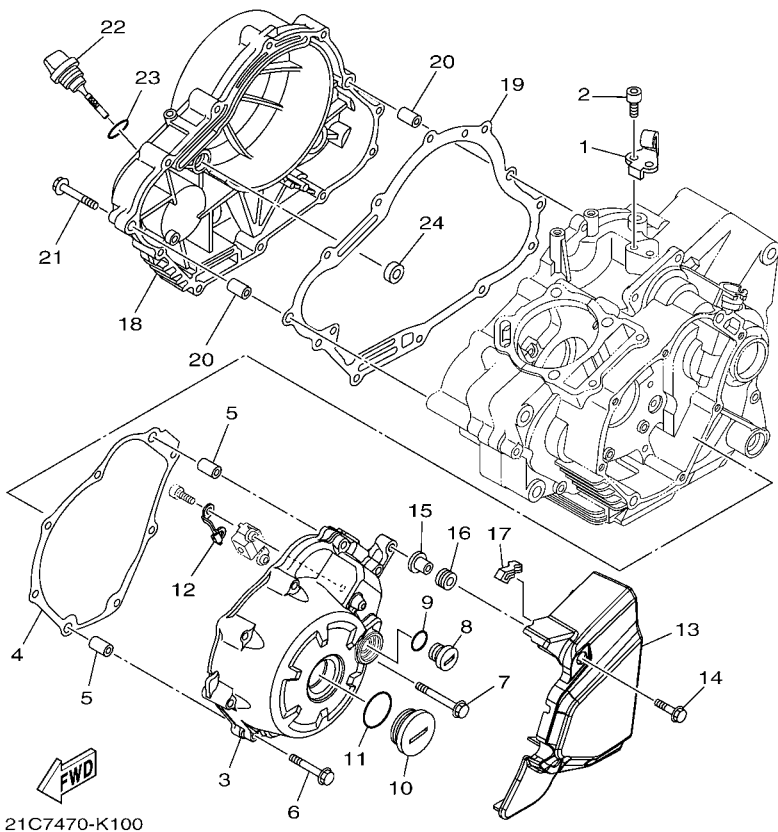
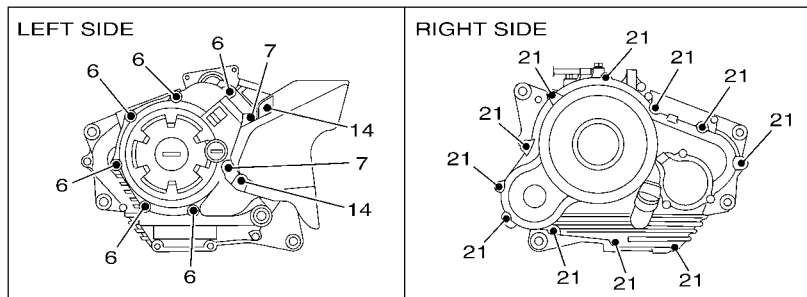
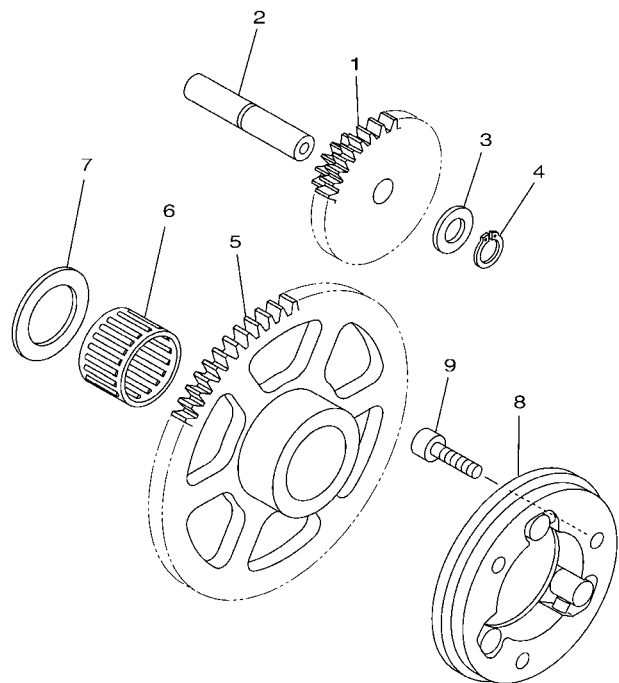


FIG. 10 CUBIERTA DE CARTER 1 CRANKCASE COVER 1

REF. Nº	CODIGO Nº PART NO.	DESCRIPCION DESCRIPTION	45D3				OBSERVACIONES REMARKS
1	21C-E5441-00	SOSTEN DE CABLE DE EMBRAGUE HOLDER, CLUTCH CABLE	1				
2	91317-06014	PERNO BOLT	2				
3	21C-E5411-10	CUBIERTA DE CARTER 1 COVER, CRANKCASE 1	1				
4	45P-E5451-00	EMPAQ DE CUBIERTA DE CARTER GASKET, CRANKCASE COVER 1	1				
5	91830-21014	PASADOR DE CLAVIJA PIN, DOWEL	2				
6	95027-06040	PERNO, DE BRIDA BOLT, FLANGE	6				
7	95027-06050	PERNO, DE BRIDA BOLT, FLANGE	2				
8	90340-14824	TORNILLO, DE DRENAJE PLUG, STRAIGHT SCREW	1				
9	93210-14899	ANILLO O O-RING	1				
10	90340-32823	TORNILLO, DE DRENAJE PLUG, STRAIGHT SCREW	1				
11	93210-32814	ANILLO O O-RING	1				
12	21C-E5113-00	PLACA PLATE	1				
13	21C-E5418-01	CUBIERTA CAJA DE CADENA COVER, CHAIN CASE	1				
14	95807-06020	TORNILLO BOLT, FLANGE	2				
15	90387-068C9	ESPACIADOR COLLAR	2				
16	90480-12812	TAPON GROMMET	2				
17	21C-E542A-00	AMORTIGUADOR 1 DAMPER 1	1				
18	21C-E5421-00	TAPA DE CARTER DERECHA COVER, CRANKCASE 2	1				
19	45P-E5461-00	JUNTA TAPA CARTER DERECHO 2 GASKET, CRANKCASE COVER 2	1				
20	91830-21014	PASADOR DE CLAVIJA PIN, DOWEL	2				
21	95027-06040	PERNO, DE BRIDA BOLT, FLANGE	11				
22	54B-E5362-00	TAPON DEL NIVEL DE ACEITE PLUG, OIL LEVEL	1				
23	93210-19809	ANILLO O O-RING	1				
24	93101-10838	SELLO ACEITE OIL SEAL	1				

**FIG. 11 EMBRAGUE DEL ARRANQUE STARTER CLUTCH**

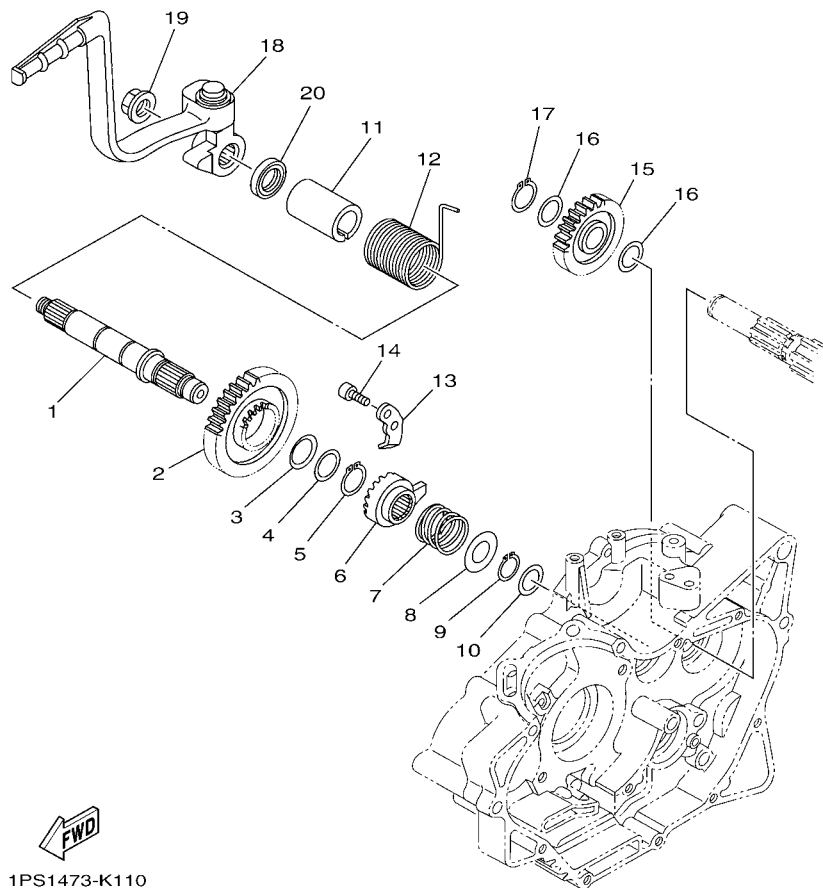


REF. Nº	CODIGO Nº PART NO.	DESCRIPCION DESCRIPTION	46D3				OBSERVACIONES REMARKS
1	21C-E5514-10	ENGRANAJE 2 GEAR 2	1				
2	21C-E5521-00	EJE 1 SHAFT 1	1				
3	90201-105E8	ARANDELA PLANA WASHER, PLATE	1				
4	99009-10400	PRESILLA REDONDA CIRCLIP	1				
5	45P-E5524-00	RUEDA DE ARRANQUE WHEEL, STARTER	1				
6	93310-325X3	COJINETE DE RODILLOS BEARING	1				
7	90201-25290	ARANDELA PLANA WASHER, PLATE	1				
8	54B-E5580-00	ENSAMBLE EXT.EMBRAGUE ARRANQUE STARTER CLUTCH OUTER ASSY	1				
9	91317-06020	PERNO BOLT	3				
-----							
-----							
-----							
-----							
-----							

  
1PS1473-K120

FIG. 12 ARRANQUE

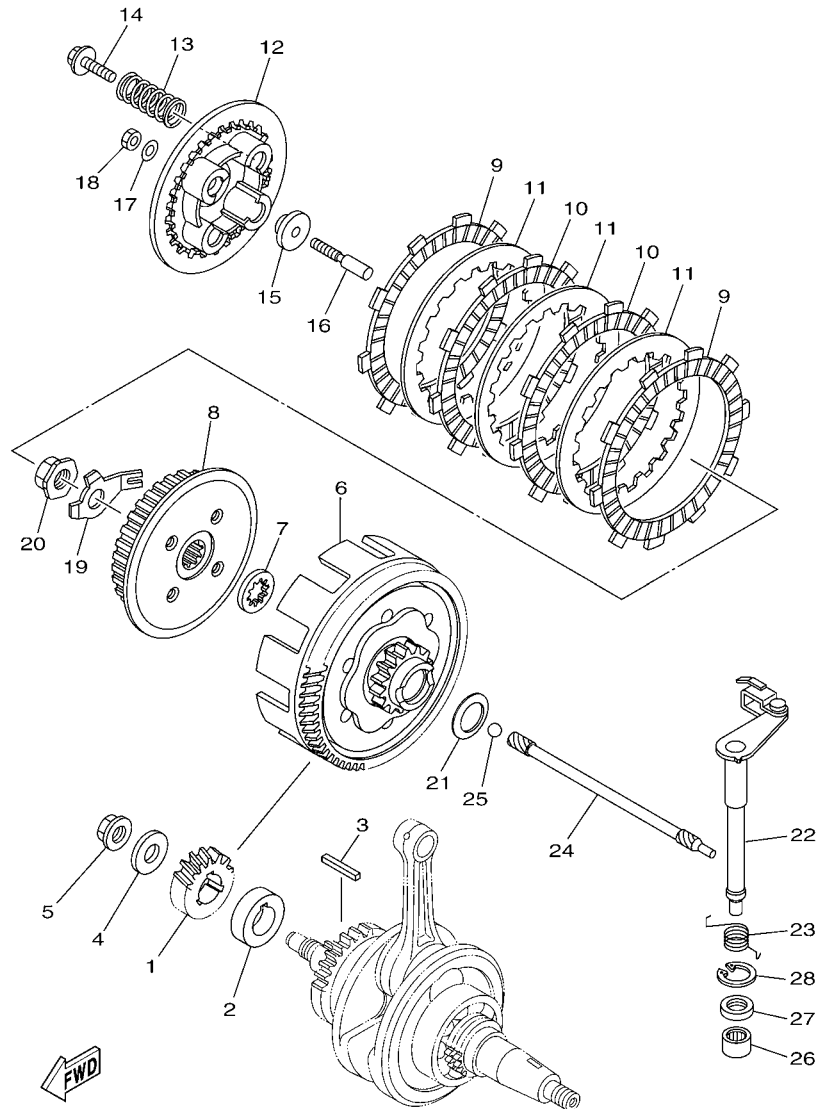
STARTER



1PS1473-K110

REF. N°	CODIGO N° PART NO.	DESCRIPCION DESCRIPTION	45D3				OBSERVACIONES REMARKS
1	54B-E5661-00	EJE DE PEDAL DE ARRANQUE AXLE, KICK	1				
2	21C-E5641-10	ENGRANAJE PEDAL ARRANQUE GEAR, KICK	1				
3	90208-20005	ARANDELA DE RESORTE CONICO WASHER, CONICAL SPRING	1				
4	90201-20685	ARANDELA PLANA (T=0.5) WASHER, PLATE (T=0.5)	1				
5	93410-20038	SEGURO CIRCLIP	1				
6	21C-E5671-00	RUEDA DE TRINQUETE WHEEL, RATCHET	1				
7	21C-E5767-00	RESORTE SPRING	1				
8	90201-167P7	ARANDELA PLANA WASHER, PLATE	1				
9	99009-16400	PRESILLA REDONDA CIRCLIP	1				
10	90201-162H4	ARANDELA PLANA WASHER, PLATE	1				
11	54B-E5664-10	GUIA DE RESORTE GUIDE, SPRING	1				
12	54B-E5665-00	RESORTE DE PEDAL DE ARRANQUE SPRING, KICK	1				
13	21C-E5674-00	GUIA DE RUEDA DE TRINQUETE GUIDE, RATCHET WHEEL	1				
14	91317-06016	PERNO BOLT	2				
15	45P-E5651-00	PINON LIBRE, PEDAL ARRANQUE GEAR, KICK IDLE	1				
16	90201-177G4	ARANDELA PLANA WASHER, PLATE	2				
17	99009-17400	PRESILLA REDONDA CIRCLIP	1				
18	21C-E5620-00	PEDAL DE ARRANQUE COMPLETO KICK CRANK ASSY	1				
19	90179-12659	TUERCA NUT	1				
20	93109-20821	SELLO ACEITE OIL SEAL	1				



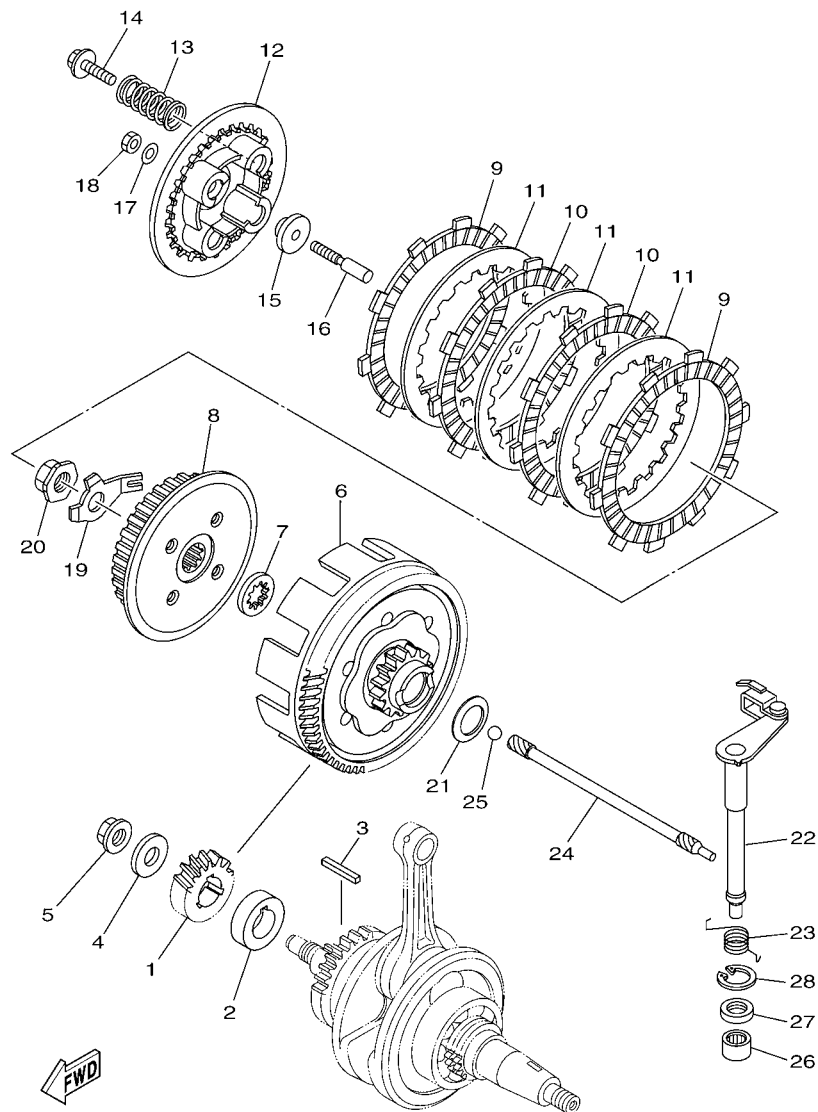


54B1470-J120

FIG. 13 EMBRAGUE

CLUTCH

REF. Nº	CODIGO Nº PART NO.	DESCRIPCION DESCRIPTION	45D3			OBSERVACIONES REMARKS
1	54B-E6111-00	ENGRANAJE TRACC.PRIMARIA GEAR, PRIMARY DRIVE	1			
2	54B-E7258-00	COLLAR 1 COLLAR 1	1			
3	21C-E6193-00	CHAVETA DE AGUJA KEY, FEATHER	1			
4	90201-12019	ARANDELA PLANA WASHER, PLATE	1			
5	90179-12802	TUERCA NUT	1			
6	54B-E6150-00	CAMPANA DE EMBRAGUE PRIMARY DRIVEN GEAR COMP.	1			
7	21C-E6154-00	ARANDELA, DE EMPUJE 1 PLATE, THRUST 1	1			
8	21C-E6371-00	CUBO, DE EMBRAGUE BOSS, CLUTCH	1			
9	54B-E6321-00	PLACA DE FRICCION PLATE, FRICTION	2			
10	21C-E6331-00	DISCO, DE FRICCION 2 PLATE, FRICTION 2	2			
11	21C-E6324-00	PLACA DE EMBRAGUE PLATE, CLUTCH 1	3			
12	54B-E6351-00	PLATO DE PRESION PLATE, PRESSURE 1	1			
13	21C-E6333-00	RESORTE DE EMBRAGUE 1 SPRING, CLUTCH 1	4			
14	21C-E6337-00	TORNILLO DE RESORTE SCREW, SPRING	4			
15	21C-E6358-00	PLACA DE EMPUJE PLATE, PUSH	1			
16	21C-E6356-01	VÁRILLA DE EMPUJE 1 ROD, PUSH 1	1			
17	54B-E6144-00	ARANDELA WASHER	1			
18	3C1-E6344-00	TUERCA DE AJUSTE NUT, ADJUSTING	1			
19	21C-E6135-10	ARANDELA DE CIERRE WASHER, LOCK	1			
20	90179-14001	TUERCA NUT	1			
21	90208-20003	ARANDELA DE RESORTE CONICO WASHER, CONICAL SPRING	1			
22	21C-E6380-01	LEVA DE EMPUJE COMPLETA PUSH LEVER ASSY	1			
23	21C-16345-10	RESORTE DE RETORNO SPRING, RETURN	1			
24	54B-E6357-00	VARILLA DE EMPUJE 2 ROD, PUSH 2	1			
25	93505-16844	BOLA BALL	1			
26	93315-112Y9	COJINETE DE RODILLOS BEARING	1			
27	93102-12877	SELLO ACEITE OIL SEAL	1			

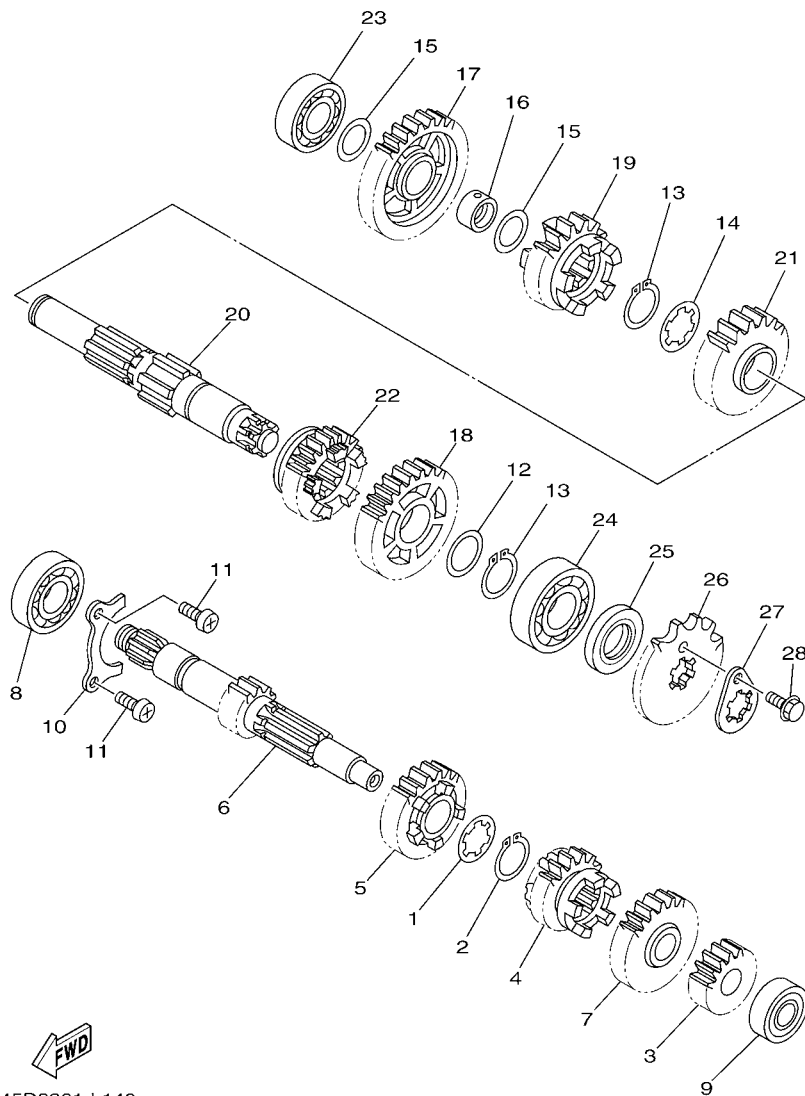


54B1470-J120

FIG. 13 EMBRAGUE

CLUTCH

REF. Nº	CODIGO Nº PART NO.	DESCRIPCION DESCRIPTION	46D3				OBSERVACIONES REMARKS
28	99009-20500	PRESILLA REDONDA CIRCLIP	1				
-----							
-----							
-----							
-----							
-----							
-----							
-----							
-----							



45D3261-L140

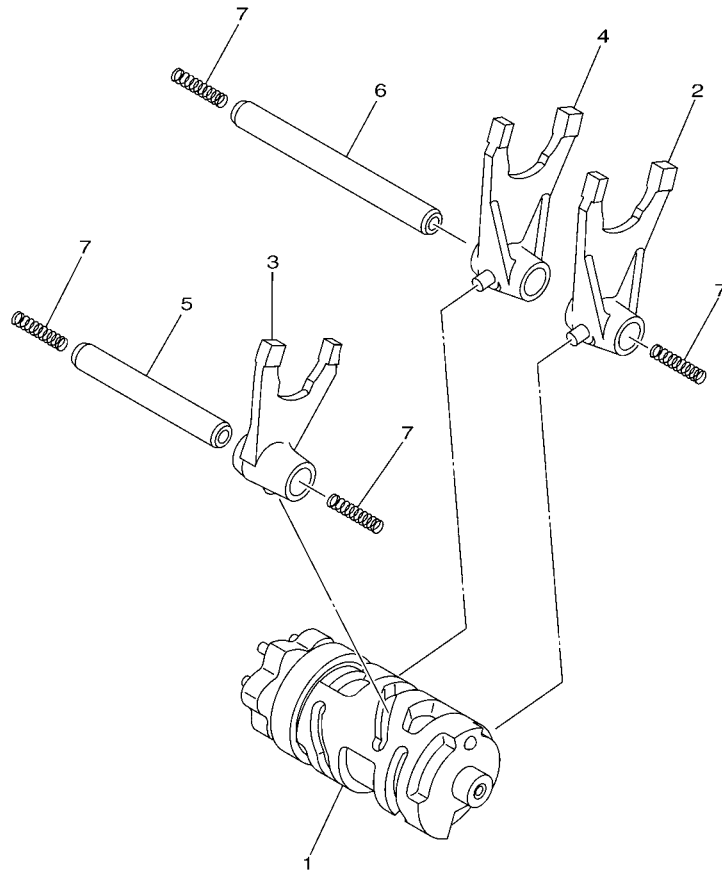
FIG. 14 TRANSMISION

TRANSMISSION

REF. Nº	CODIGO Nº PART NO.	DESCRIPCION DESCRIPTION	45D3				OBSERVACIONES REMARKS
1	90209-17285	ARANDELA DE SEPARACION WASHER	1				
2	93410-20038	SEGURO CIRCLIP	1				
3	21C-E7121-00	ENGRANAJE PINON DE 2DA (19T) GEAR, 2ND PINION (19T)	1				
4	21C-E7131-20	ENGRANAJE PINON DE 3RA (22T) GEAR, 3RD PINION (22T)	1				
5	21C-E7141-40	ENGRANAJE PINON DE 4TA (22T) GEAR, 4TH PINION (22T)	1				
6	21C-E7411-40	EJE PRIMARIO (14T) AXLE, MAIN (14T)	1				
7	21C-E7151-40	ENGRANAJE PINON DE 5TA (24T) GEAR, 5TH PINION (24T)	1				
8	93306-054YE	COJINETE BEARING	1				UR
	93306-054Y6	COJINETE BEARING	1				UR
9	93306-201Y4	COJINETE BEARING	1				UR
10	21C-E7471-00	PLACA, DE CUBIERTA PLATE, COVER	1				
11	98517-06012	TORNILLO DE CABEZA CON PLANA SCREW, PAN HEAD	2				
12	90201-22793	ARANDELA PLANA WASHER, PLATE	1				
13	93410-22039	SEGURO CIRCLIP	2				
14	90209-18208	ARANDELA DE SEPARACION WASHER	1				
15	90201-177G4	ARANDELA PLANA WASHER, PLATE	2				
16	21C-E7258-00	COLLAR 1 COLLAR 1	1				
17	21C-E7211-20	ENGRANAJE RUEDA DE 1 RA (38T) GEAR, 1ST WHEEL (38T)	1				
18	21C-E7221-20	ENGRANAJE RUEDA DE 2DA (34T) GEAR, 2ND WHEEL (34T)	1				
19	21C-E7241-40	ENGRANAJE DE RUEDA 4TA (23T) GEAR, 4TH WHEEL (23T)	1				
20	21C-E7402-40	EJE DE TRACCION COMPLETO DRIVE AXLE ASSY	1				
21	21C-E7231-30	ENGRANAJE RUEDA DE 3RA (29T) GEAR, 3RD WHEEL (29T)	1				
22	21C-E7251-40	ENGRANAJE RUEDA DE 5TA (21T) GEAR, 5TH WHEEL (21T)	1				
23	93306-203XR	COJINETE BEARING	1				
24	93306-272X4	COJINETE BEARING	1				UR
	93306-272X1	COJINETE BEARING	1				UR
25	93102-22818	SELLO ACEITE OIL SEAL	1				

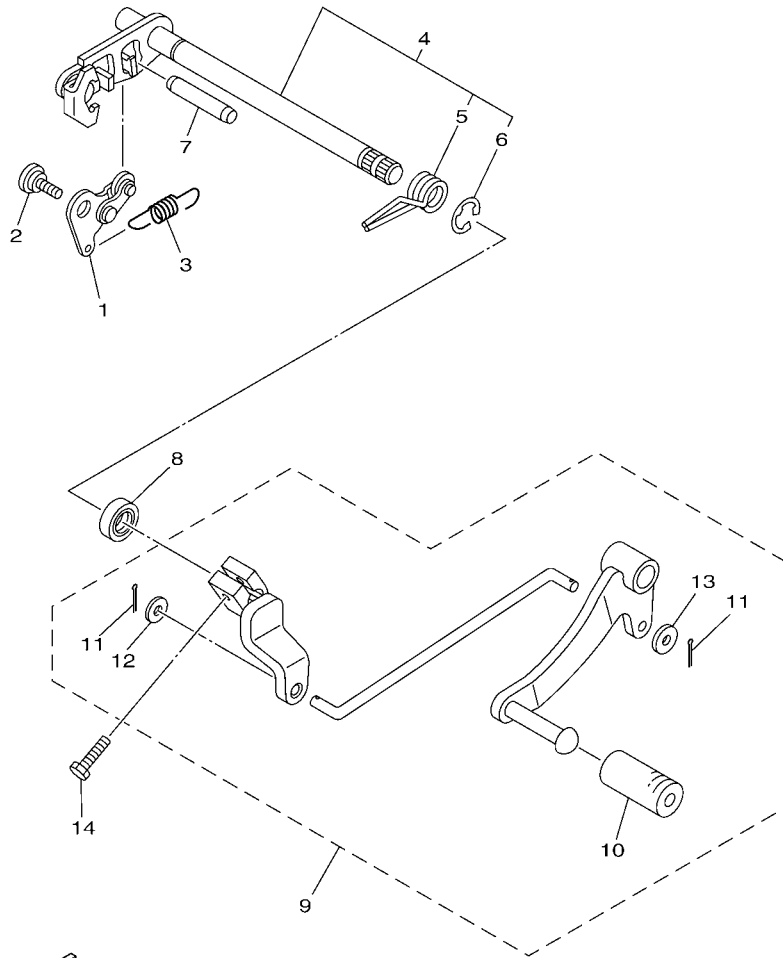


FIG. 15 LEVA DE CAMBIO & HORQUILLA SHIFT CAM & FORK



REF. Nº	CODIGO Nº PART NO.	DESCRIPCION DESCRIPTION	46D3				OBSERVACIONES REMARKS
1	21C-E8540-30	LEVA DEL CAMBIO COMPLETA SHIFT CAM ASSY	1				
2	21C-E8511-00	HORQUILLA DEL CAMBIO 1 FORK, SHIFT 1	1				
3	21C-E8512-00	HORQUILLA DEL CAMBIO 2 FORK, SHIFT 2	1				
4	21C-E8513-00	HORQUILLA DEL CAMBIO 3 FORK, SHIFT 3	1				
5	21C-E8531-00	BARRA GUIA HORQ. CAMBIO 1 BAR, SHIFT FORK GUIDE 1	1				
6	21C-E8535-00	BARRA GUIA HORQ. CAMBIO 2 BAR, SHIFT FORK GUIDE 2	1				
7	90501-06800	RESORTE DE COMPRESION SPRING, COMPRESSION	4				

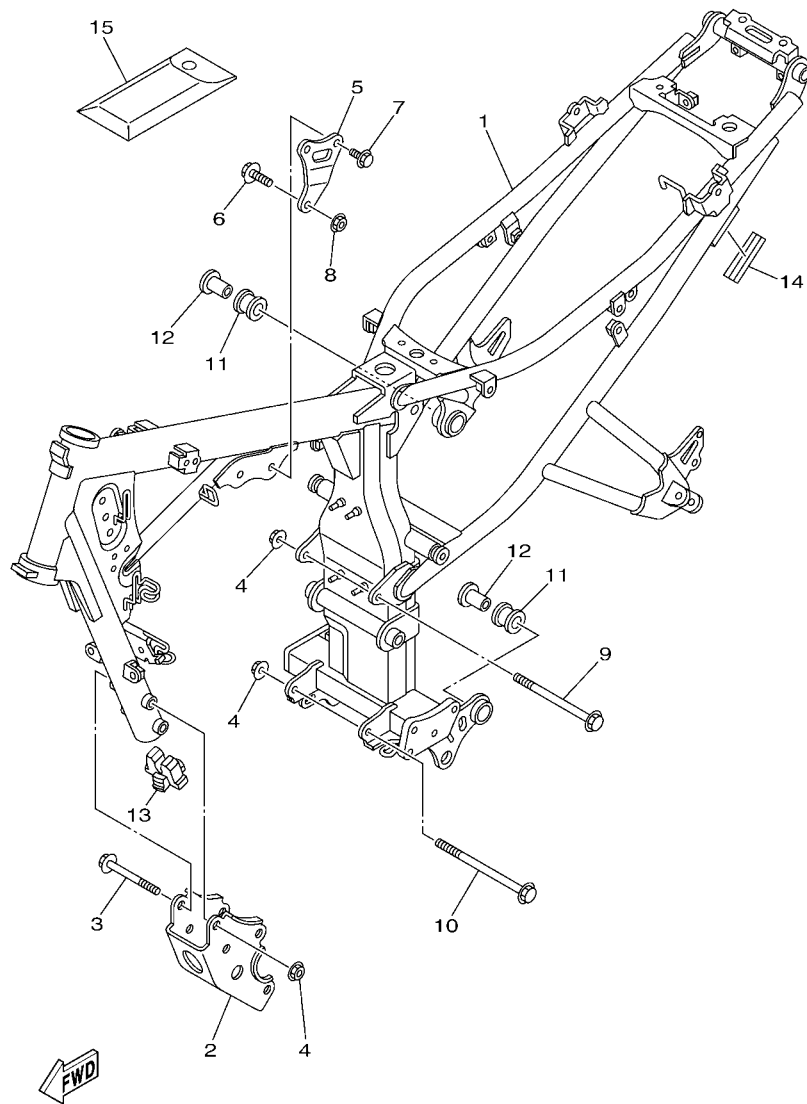
 21C1470-G140



21C1470-G152

FIG. 16 EJE DE CAMBIO & PEDAL SHIFT SHAFT

REF. N°	CODIGO N° PART NO.	DESCRIPCION DESCRIPTION	46D3				OBSERVACIONES REMARKS
1	21C-E8140-00	PALANCA DE TOPE COMPLETA STOPPER LEVER ASSY	1				
2	90109-06259	PERNO BOLT	1				
3	21C-E8337-00	RESORTE SPRING	1				
4	21C-E8101-01	EJE SELECTOR COMPLETO SHIFT SHAFT ASSY	1				
5	90508-32805	.RESORTE DE TORSION .SPRING, TORSION	1				
6	99001-10600	.PRESILLA REDONDA .CIRCLIP	1				
7	93608-43238	PASADOR DE CLAVIJA PIN, DOWEL	1				
8	93102-12875	SELLO ACEITE OIL SEAL	1				
9	45D-E8110-00	PEDAL DE CAMBIO COMPLETO SHIFT PEDAL ASSY	1				
10	5VA-E8113-00	.FUNDA DEL PEDAL DEL CAMBIO .COVER, SHIFT PEDAL	1				
11	91401-20012	.CHAVETA .PIN, COTTER	2				
12	92907-06200	.ARANDELA .WASHER	1				
13	90201-060H9	.ARANDELA PLANA .WASHER, PLATE	1				
14	97012-06020	PERNO BOLT	1				



45D3261-L170

FIG. 17 CUADRO

FRAME

REF. N°	CODIGO N° PART NO.	DESCRIPCION DESCRIPTION	45D3				OBSERVACIONES REMARKS
1	45D-F1110-20	ARMAZON COMPLETO FRAME COMP.	1				
2	45D-F1316-00	SOPORTE DE MOTOR 3 STAY, ENGINE 3	1				
3	95817-10080	TORNILLO BOLT, FLANGE	4				
4	90179-10658	TUERCA NUT	6				
5	45D-F1317-00	SOPORTE DE MOTOR 3 STAY, ENGINE 3	1				
6	95817-08035	TORNILLO BOLT, FLANGE	1				
7	95817-08016	TORNILLO BOLT, FLANGE	2				
8	90179-08674	TUERCA NUT	1				
9	95817-10130	TORNILLO BOLT, FLANGE	1				
10	90105-10079	TORNILLO BOLT, FLANGE	1				
11	20P-E4747-00	AMORTIGUADOR DE SILENCIADOR DAMPER, MUFFLER	2				
12	90387-08822	ESPACIADOR COLLAR	2				
13	21C-F1638-01	AMORTIGUADOR 1 DAMPER 1	1				
14	45D-F113B-00	AMORTIGUADOR DAMPER	1				
15	21C-F8100-20	JUEGO DE HERRAMIENTAS TOOL KIT	1				

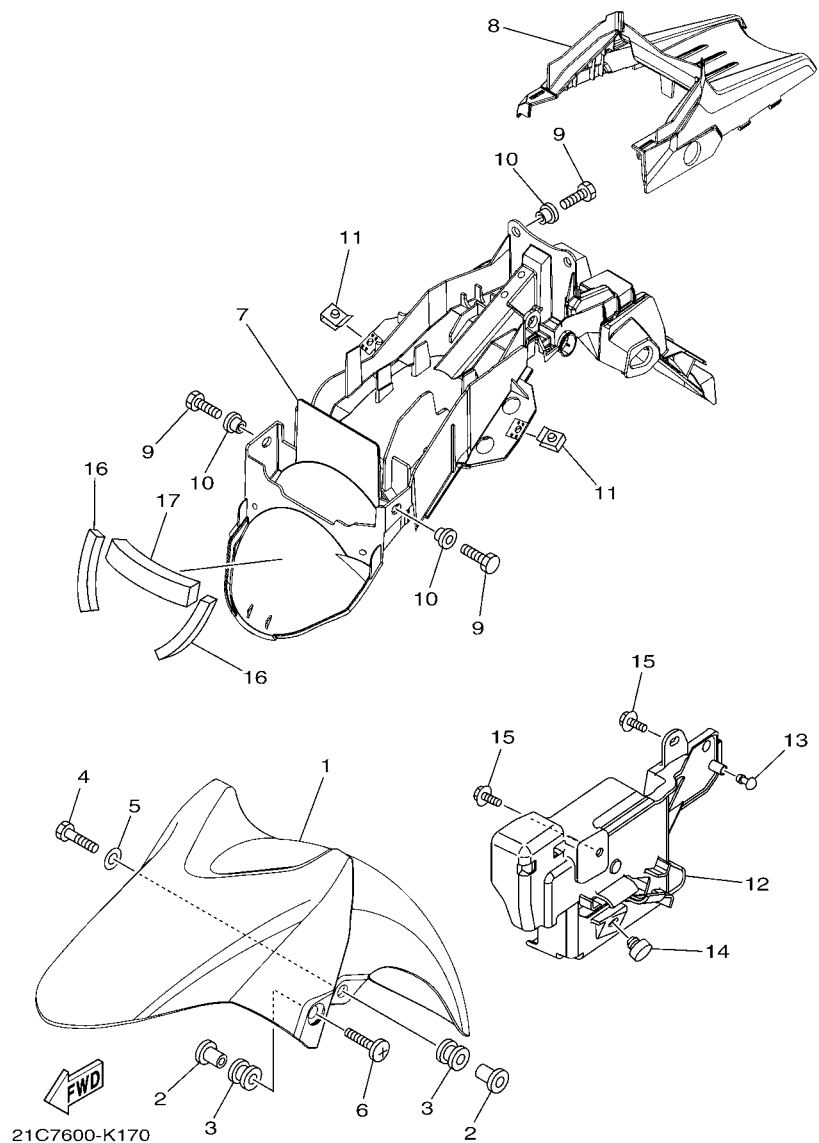
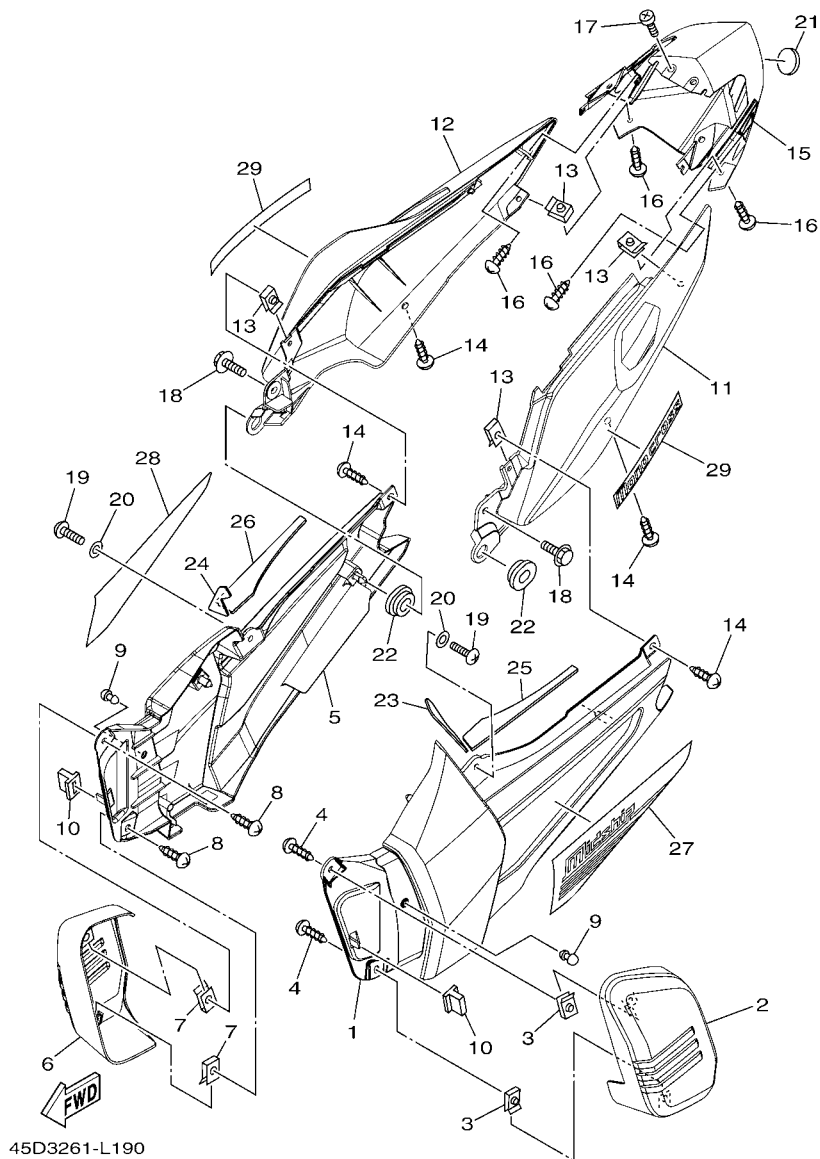


FIG. 18 GUARDABARRO

FENDER

REF. Nº	CODIGO Nº PART NO.	DESCRIPCION DESCRIPTION	45D3			OBSERVACIONES REMARKS
1	45D-F1511-10-0X	GUARDABARRO DELANTERO FENDER, FRONT	1			UR PARA YB UR FOR YB
	45D-F1511-10-1X	GUARDABARRO DELANTERO FENDER, FRONT	1			UR PARA DRMK UR FOR DRMK
	45D-F1511-10-3X	GUARDABARRO DELANTERO FENDER, FRONT	1			UR PARA BMC UR FOR BMC
	45D-F1511-10-2X	GUARDABARRO DELANTERO FENDER, FRONT	1			UR PARA YRC2 UR FOR YRC2
2	90387-068C5	ESPACIADOR COLLAR	4			
3	90480-08801	TAPON GROMMET	4			
4	97027-06020	PERNO BOLT, HEXAGON	2			
5	90201-06726	ARANDELA PLANA WASHER, PLATE	2			
6	90154-06061	TORNILLO DE LIGAR SCREW, BINDING	2			
7	21C-F1611-00	GUARDABARRO TRASERO FENDER, REAR	1			
8	21C-F1651-00	TAPA DE GUARDABARRO TRAS. COVER, REAR FENDER	1			
9	97017-06014	PERNO BOLT	4			
10	90387-06048	ESPACIADOR COLLAR	4			
11	90183-05042	TUERCA DE RESORTE NUT, SPRING	2			
12	21C-F177G-10	CAJA DE BATERIA BOX, BATTERY	1			
13	21C-F1717-00	AMORTIGUADOR DAMPER	1			
14	4LS-F4741-00	COJIN DE ASIENTO PAD, SEAT	1			
15	90119-06117	TORNILLO CON ARANDELA BOLT, WITH WASHER	2			
16	21C-F1669-00	SELLO SEAL	2			
17	21C-F16A2-00	SELLO 2 SEAL, 2	1			





45D3261-L190

FIG. 19 CUBIERTA LATERAL

SIDE COVER

REF. Nº	CODIGO Nº PART NO.	DESCRIPCION DESCRIPTION	45D3			OBSERVACIONES REMARKS
1	45D-F1711-10-P0	CUBIERTA LATERAL 1 COVER, SIDE 1	1			S8 S8
2	45D-F172A-10-P0	PANEL 1 PANEL 1	1			S8 S8
3	90183-05042	TUERCA DE RESORTE NUT, SPRING	2			
4	97707-50012	TORNILLO SCREW, TRUSS HEAD TAPPING	2			
5	45D-F1721-10-P0	CUBIERTA LATERAL 2 COVER, SIDE 2	1			S8 S8
6	45D-F172F-10-P0	PANEL 2 PANEL 2	1			S8 S8
7	90183-05042	TUERCA DE RESORTE NUT, SPRING	2			
8	97707-50012	TORNILLO SCREW, TRUSS HEAD TAPPING	2			
9	21C-F1717-00	AMORTIGUADOR DAMPER	2			
10	5DG-F1778-00	AMORTIGUADOR DE MONTAJE DAMPER, LOCATING 1	2			
11	45D-F1731-00-33	TAPA LATERAL 3 COVER, SIDE 3	1			YB YB
12	45D-F1741-00-33	TAPA LATERAL 4 COVER, SIDE 4	1			YB YB
13	90183-05042	TUERCA DE RESORTE NUT, SPRING	4			
14	97707-50012	TORNILLO SCREW, TRUSS HEAD TAPPING	4			
15	45D-F171E-01-33	CUBIERTA LATERAL 5 COVER, SIDE 5	1			YB YB
16	97707-50012	TORNILLO SCREW, TRUSS HEAD TAPPING	4			
17	98507-06012	TORNILLO DE CABEZA PLANA SCREW, PAN HEAD	2			
18	90119-06044	TORNILLO CON ARANDELA BOLT, WITH WASHER	2			
19	98502-06016	TORNILLO SCREW, PAN HEAD	2			
20	90201-06055	ARANDELA PLANA WASHER, PLATE	2			
21	22P-F836B-00	MARCA TUNING FORK MARK	1			
22	90480-01559	TAPON GROMMET	2			
23	45D-F1732-00	SELLO 1 SEAL 1	1			
24	45D-F1735-00	SELLO 2 SEAL 2	1			
25	45D-F173M-00	SELLO 3 SEAL 3	1			
26	45D-F173N-00	SELLO 4 SEAL 4	1			
27	45D-F173E-00	GRAFICO, 1 GRAPHIC, 1	1			UR PARA YB UR FOR YB

45D3261-L190

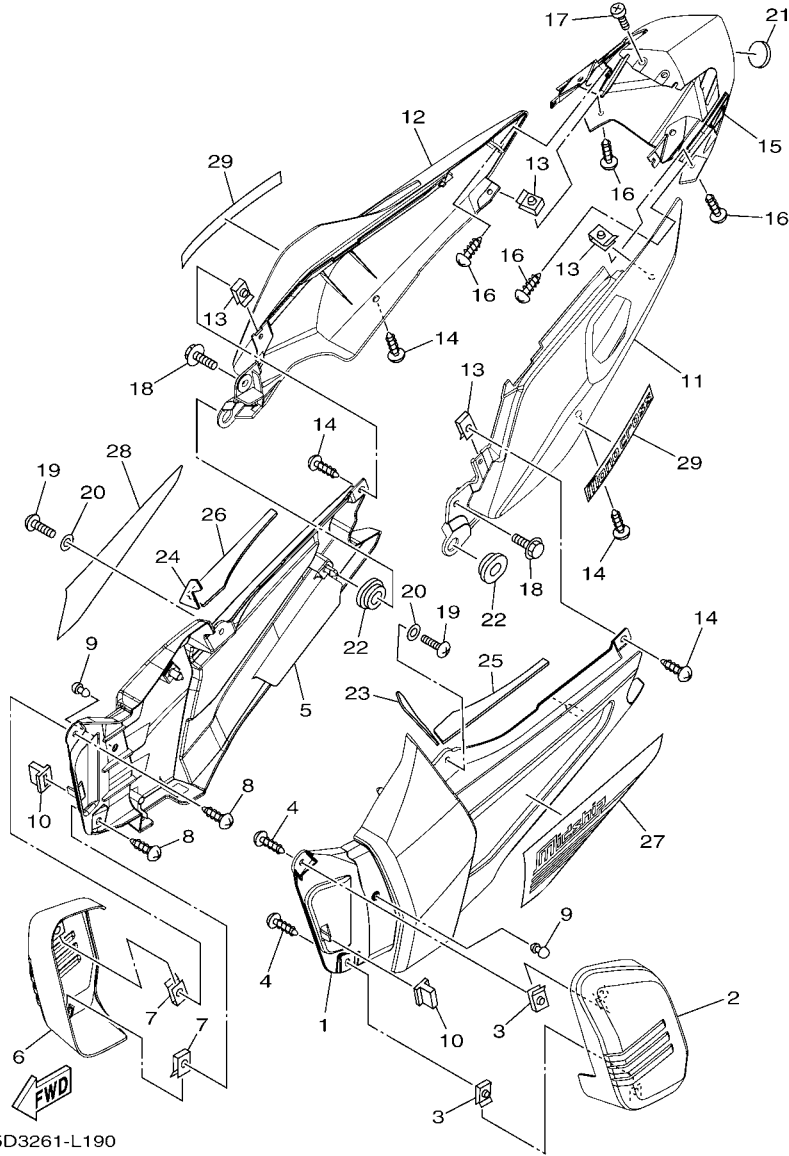
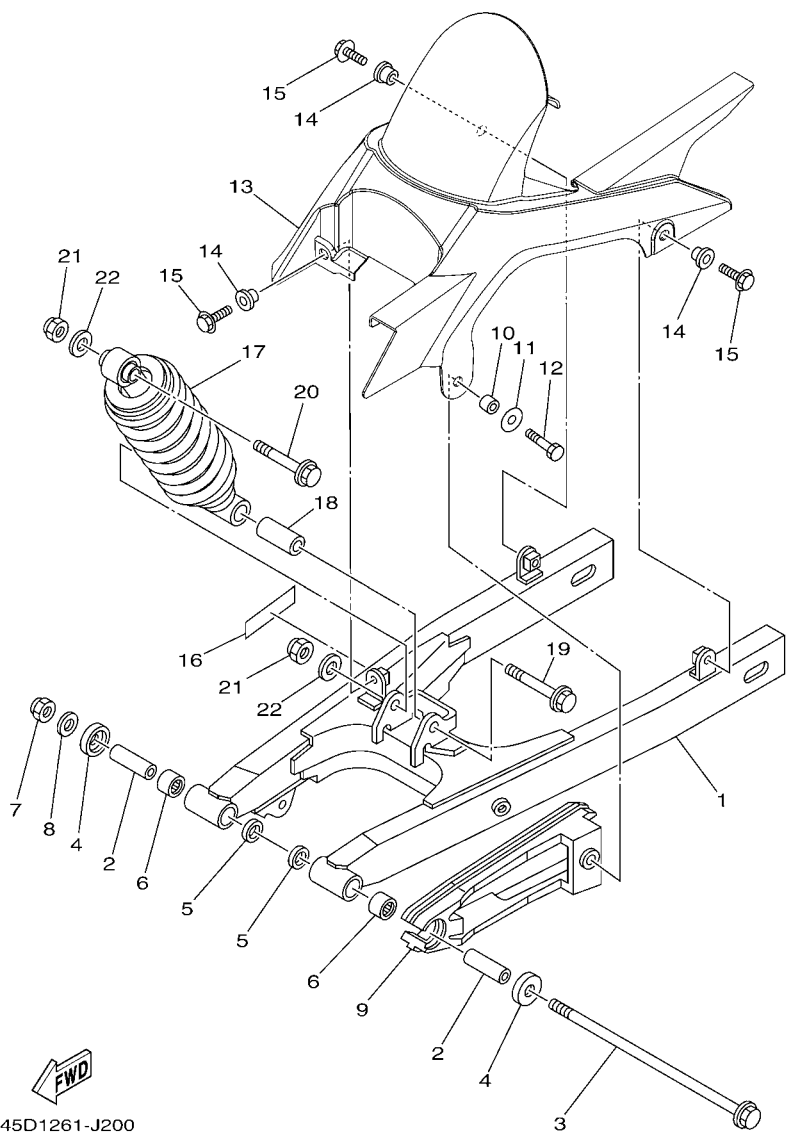


FIG. 19 CUBIERTA LATERAL

SIDE COVER

REF. Nº	CODIGO Nº PART NO.	DESCRIPCION DESCRIPTION	45D3			OBSERVACIONES REMARKS
27	45D-F173E-10	GRAFICO, 1 GRAPHIC, 1	1			UR PARA DRMK UR FOR DRMK
	45D-F173E-20	GRAFICO, 1 GRAPHIC, 1	1			UR PARA BMC UR FOR BMC
	45D-F173E-30	GRAFICO, 1 GRAPHIC, 1	1			UR PARA YRC2 UR FOR YRC2
28	45D-F173F-00	GRAFICO 2 GRAPHIC, 2	1			UR PARA YB UR FOR YB
	45D-F173F-10	GRAFICO 2 GRAPHIC, 2	1			UR PARA DRMK UR FOR DRMK
	45D-F173F-20	GRAFICO 2 GRAPHIC, 2	1			UR PARA BMC UR FOR BMC
	45D-F173F-30	GRAFICO 2 GRAPHIC, 2	1			UR PARA YRC2 UR FOR YRC2
29	45D-F174G-00	GRAFICO 3 GRAPHIC, 3	2			UR PARA YB UR FOR YB
	45D-F174G-10	GRAFICO 3 GRAPHIC, 3	2			UR PARA DRMK UR FOR DRMK
	45D-F174G-20	GRAFICO 3 GRAPHIC, 3	2			UR PARA BMC UR FOR BMC
	45D-F174G-30	GRAFICO 3 GRAPHIC, 3	2			UR PARA YRC2 UR FOR YRC2

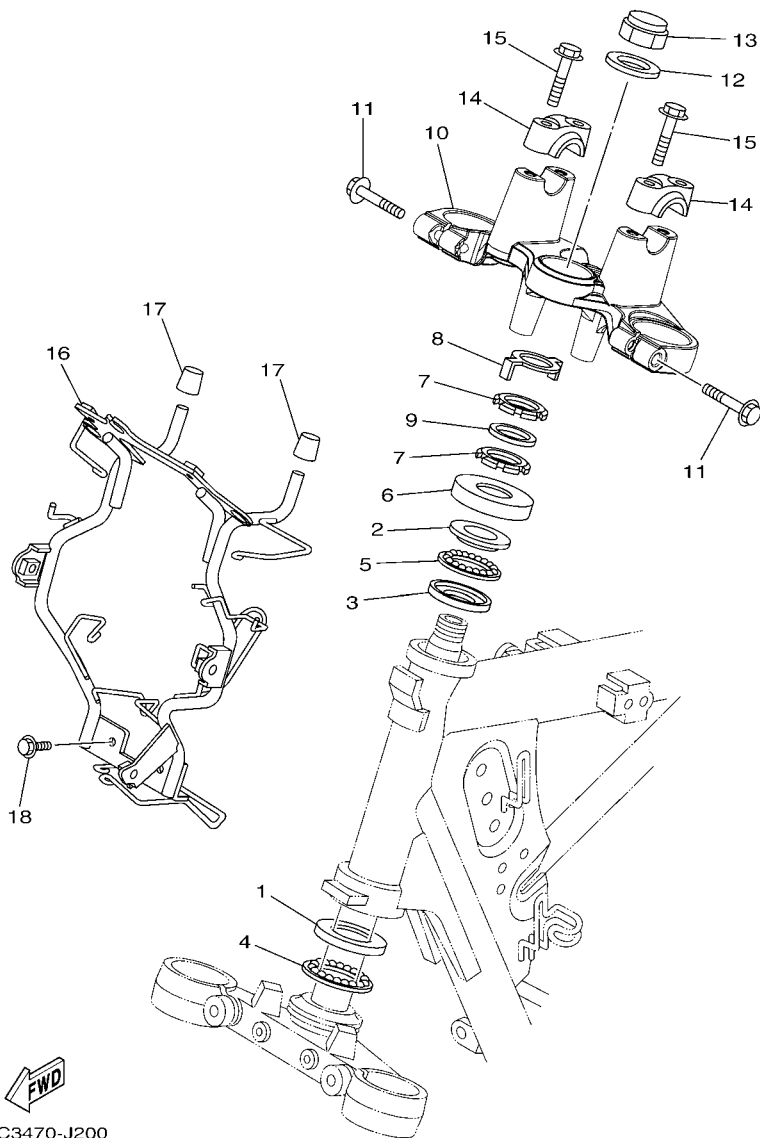
**FIG. 20 BRAZO TRASERO & SUSPENSION REAR ARM & SUSPENSION**



REF. Nº	CODIGO Nº PART NO.	DESCRIPCION DESCRIPTION	45D3				OBSERVACIONES REMARKS
1	45D-F2110-00	BRAZO TRASERO COMPLETO REAR ARM COMP.	1				
2	21C-F2184-00	BUJE BUSH	2				
3	21C-F2141-00	EJE DEL BARCULANTE SHAFT, PIVOT	1				
4	20P-F2129-00	TAPA DE EMPUJE 2 COVER, THRUST 2	2				
5	93109-18803	SELLO ACEITE OIL SEAL	2				
6	93317-318Y5	COJINETE BEARING	2				
7	95614-12100	TUERCA AUTOBLOCANTE NUT, U	1				
8	90201-12030	ARANDELA PLANA WASHER, PLATE	1				
9	21C-F2151-00	SELLO DE GUARDA SEAL, GUARD	1				
10	90387-066J9	ESPACIADOR COLLAR	1				
11	90201-060A3	ARANDELA PLANA WASHER, PLATE	1				
12	97027-06025	PERNO BOLT, HEXAGON	1				
13	21C-F1650-00	GUARDABARRO TRASERO COMP. REAR FENDER COMP.	1				
14	90387-068S1	ESPACIADOR COLLAR	3				
15	95807-06014	TORNILLO BOLT, FLANGE	3				
16	45D-F1668-00	ETIQUETA DE FRANJA LABEL, TIRE	1				
17	21C-F2210-00	AMORTIGUADOR TRASERO COMPLETO SHOCK ABSORBER ASSY, REAR	1				
18	90387-12845	ESPACIADOR COLLAR	1				
19	90105-12660	TORNILLO BOLT, FLANGE	1				
20	90105-12030	TORNILLO BOLT, FLANGE	1				
21	95617-12100	TUERCA NUT, U	2				
22	90201-122H1	ARANDELA PLANA WASHER, PLATE	2				

FIG. 21 DIRECCION

STEERING



21C3470-J200

REF. N°	CODIGO N° PART NO.	DESCRIPCION DESCRIPTION	45D3				OBSERVACIONES REMARKS
1	5KA-F3412-00	PISTA DE BOLAS 2 RACE, BALL 2	1				
2	5KA-F3413-00	BASE DE BOLA 3 RACE, BALL 3	1				
3	5KA-F3414-00	BASE DE BOLA 4 RACE, BALL 4	1				
4	4LS-F341E-10	RETEN DE COJINETE RETAINER, BALL BEARING	1				
5	4LS-F341E-00	RETEN DE COJINETE RETAINER, BALL BEARING	1				
6	5YY-F3416-00	CUBIERTA DE BASE DE BOLA 2 COVER, BALL RACE 2	1				
7	90179-25615	TUERCA NUT	2				
8	3YF-23418-00	ARANDELA ESPECIAL WASHER, SPECIAL	1				
9	90202-26142	ARANDELA DE PLANA WASHER, PLATE	1				
10	21C-F3435-00	PLATINA SUPERIOR CROWN, HANDLE	1				
11	95027-08040	PERNO, DE BRIDA BOLT, FLANGE	2				
12	90201-220T0	ARANDELA PLANA WASHER, PLATE	1				
13	90176-22081	TUERCA CORONA NUT, CROWN	1				
14	21C-F3441-00	SOPORTE DE MANUBRIO HOLDER, HANDLE UPPER	2				
15	95024-08035	PERNO, BRIDA BOLT, FLG. (SMALL HEAD)	4				
16	45D-F3174-00	SOPORTE DEL FARO DELANTERO STAY, HEADLIGHT	1				
17	21C-F317J-00	AMORTIGUADOR 1 DAMPER 1	2				
18	95827-06012	TORNILLO BOLT, FLANGE	2				

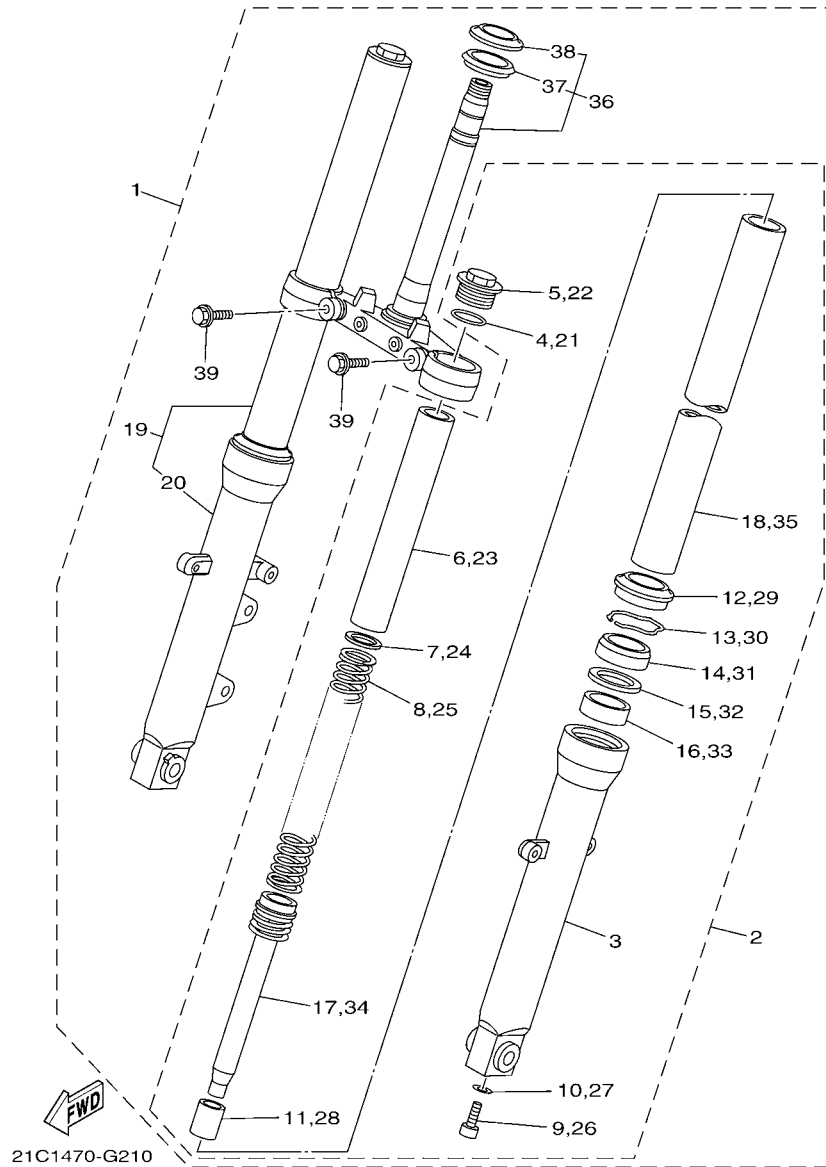
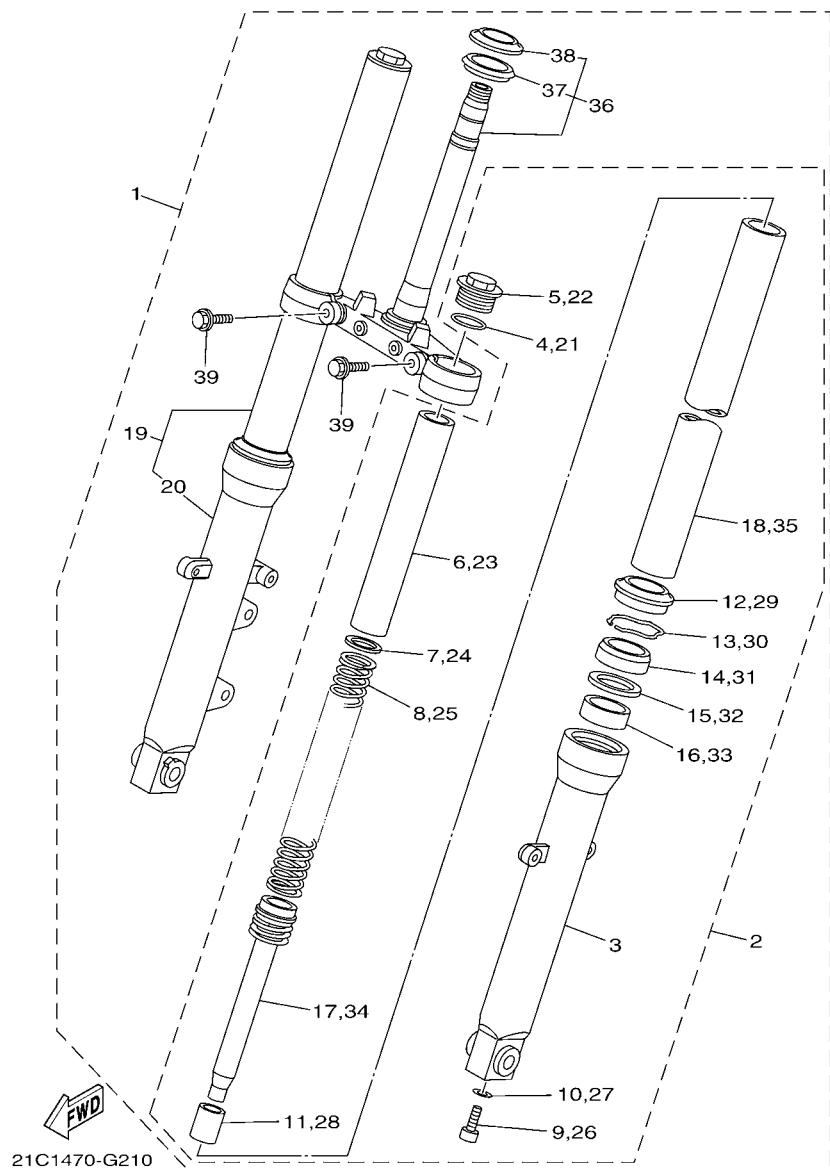


FIG. 22 HORQUILLA DELANTERA FRONT FORK

REF. Nº	CODIGO Nº PART NO.	DESCRIPCION DESCRIPTION	45D3				OBSERVACIONES REMARKS
1	21C-F3100-01	HORQUILLA DELANTERA COMPLETA FRONT FORK ASSY	1				
2	21C-F3102-01	..HORQUILLA DELANTERA COMPL.(MI) ..FRONT FORK ASSY (L.H)	1				
3	21C-F3126-01	..TUBO EXTERIOR (IZQUIERDO) ..TUBE, OUTER (LEFT)	1				
4	21C-F3114-00	..EMPAQUE ..GASKET	1				
5	21C-F3111-00	..PERNO DE TAPA ..BOLT, CAP	1				
6	21C-F3118-00	..SEPARADOR ..SPACER	1				
7	21C-F3149-00	..ARANDELA DE RESORTE SUPERIOR ..WASHER, SPRING UPPER	1				
8	21C-F3141-00	..RESORTE HORQUILLA DELANT. ..SPRING, FRONT FORK	1				
9	21C-F3181-00	..TORNILLO CABEZAHEXAGONAL ..BOLT, HEXAGON SOCKET HEAD	1				
10	21C-F3158-00	..EMPAQUE ..GASKET	1				
11	21C-F3173-00	..VASTAGO AHUSADO ..SPINDLE, TAPER	1				
12	4EB-23144-00	..GUARDAPOLVO ..SEAL, DUST	1				
13	21C-F3156-00	..ANILLO DE ENGANCHE ..RING, SNAP	1				
14	4EB-23145-01	..RETEN DE ACEITE ..OIL SEAL	1				
15	21C-F3146-00	..ARANDELA DE SELLO DE ACEITE ..WASHER, OIL SEAL	1				
16	4FM-23125-40	..METAL CORREDIZO 1 ..METAL, SLIDE 1	1				
17	21C-F3170-00	..CILINDRO COMPL DE HORQ DELANT ..CYLINDER COMP, FRONT FORK	1				
18	21C-F3110-00	..TUBO INTERIOR COMPLETO 1 ..INNER TUBE COMP.1	1				
19	21C-F3103-01	..HORQUILLA DELANTERA COMPL.(MD) ..FRONT FORK ASSY (R.H)	1				
20	21C-F3136-01	..TUBO EXTERIOR (DERECHO) ..TUBE, OUTER (RIGHT)	1				
21	21C-F3114-00	..EMPAQUE ..GASKET	1				
22	21C-F3111-00	..PERNO DE TAPA ..BOLT, CAP	1				
23	21C-F3118-00	..SEPARADOR ..SPACER	1				
24	21C-F3149-00	..ARANDELA DE RESORTE SUPERIOR ..WASHER, SPRING UPPER	1				
25	21C-F3141-00	..RESORTE HORQUILLA DELANT. ..SPRING, FRONT FORK	1				
26	21C-F3181-00	..TORNILLO CABEZAHEXAGONAL ..BOLT, HEXAGON SOCKET HEAD	1				
27	21C-F3158-00	..EMPAQUE ..GASKET	1				

FIG. 22 HORQUILLA DELANTERA

FRONT FORK



REF. Nº	CODIGO Nº PART NO.	DESCRIPCION DESCRIPTION	45D3				OBSERVACIONES REMARKS
28	21C-F3173-00	..VASTAGO AHUSADO ..SPINDLE, TAPER	1				
29	4EB-23144-00	..GUARDAPOLVO ..SEAL, DUST	1				
30	21C-F3156-00	..ANILLO DE ENGANCHE ..RING, SNAP	1				
31	4EB-23145-01	..RETEN DE ACEITE ..OIL SEAL	1				
32	21C-F3146-00	..ARANDELA DE SELLO DE ACEITE ..WASHER, OIL SEAL	1				
33	4FM-23125-40	..METAL CORREDIZO 1 ..METAL, SLIDE 1	1				
34	21C-F3170-00	..CILINDRO COMPL DE HORQ DELANT ..CYLINDER COMP., FRONT FORK	1				
35	21C-F3110-00	..TUBO INTERIOR COMPLETO 1 ..INNER TUBE COMP.1	1				
36	21C-F3340-00	..PLATINA INFERIOR COMPLETA ..UNDER BRACKET COMP.	1				
37	5YY-F3462-00	..SELLO PARA POLVO ..SEAL, DUST	1				
38	5KA-F3411-00	..PISTA DE BOLAS 1 ..RACE, BALL 1	1				
39	21C-F3346-00	..PERNO 1 ..BOLT 1	2				

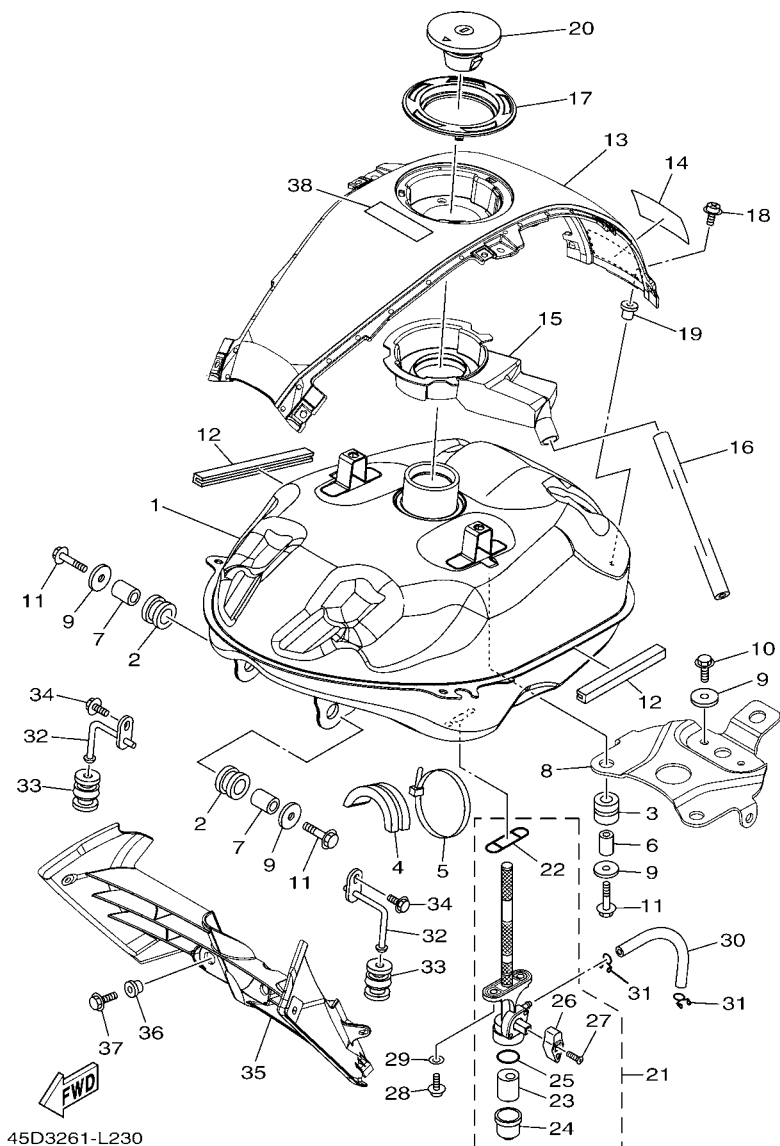


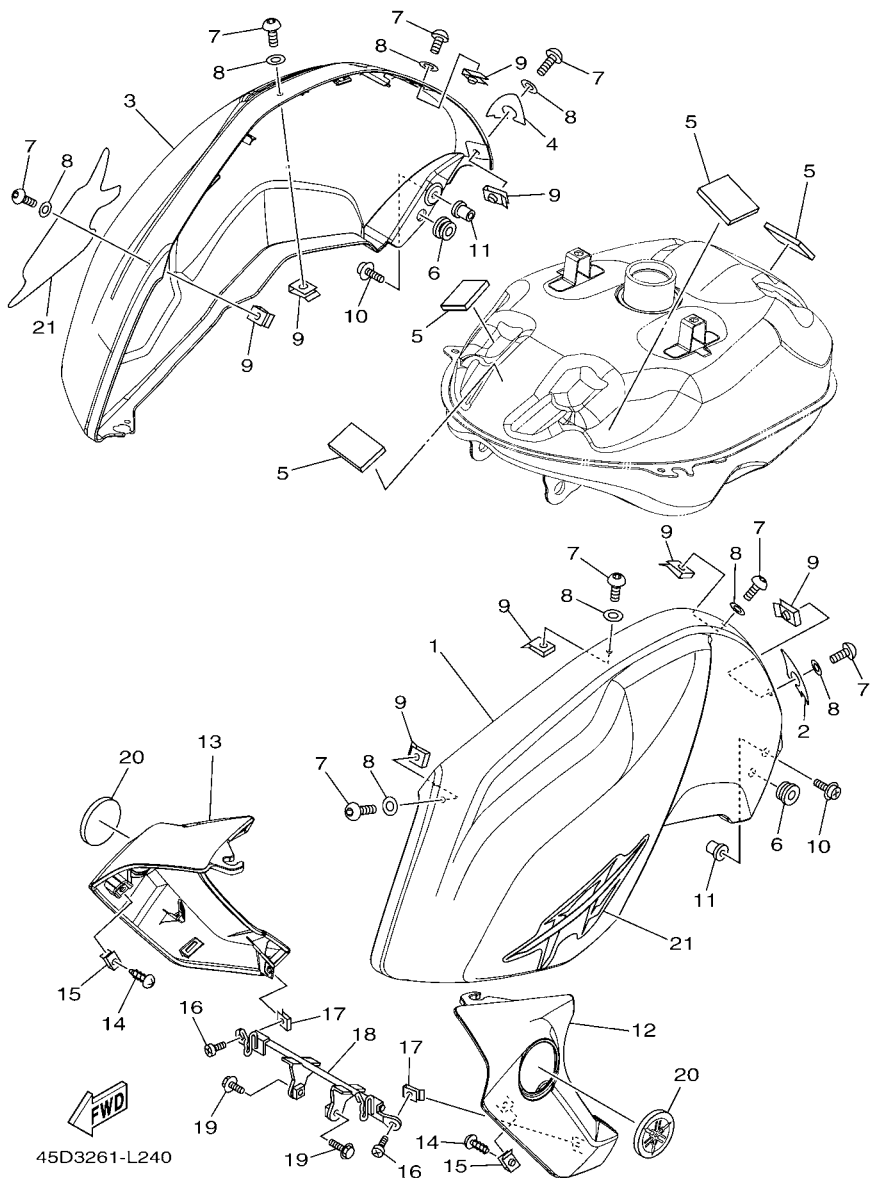
FIG. 23 DEPOSITO DE COMBUSTIBLE FUEL TANK

REF. Nº	CODIGO Nº PART NO.	DESCRIPCION DESCRIPTION	45D3			OBSERVACIONES REMARKS
1	45D-F4110-10	DEPOSITO DE COMBUSTIBLE COMP. FUEL TANK COMP.	1			
2	21C-F4181-00	AMORTIGUADOR DE MONTAJE 1 DAMPER, LOCATING 1	2			
3	21C-F4182-00	AMORTIGUADOR DE MONTAJE 2 DAMPER, LOCATING 2	2			
4	21C-F4183-00	AMORTIGUADOR DE MONTAJE 3 DAMPER, LOCATING 3	1			
5	90464-80802	BRIDA CLAMP	1			
6	90387-06554	ESPACIADOR COLLAR	2			
7	90387-107H6	ESPACIADOR COLLAR	2			
8	45D-F4191-00	SOPORTE DEPOSITO DE COMBUST.1 BRACKET, FUEL TANK 1	1			
9	90201-060A3	ARANDELA PLANA WASHER, PLATE	6			
10	95827-06012	TORNILLO BOLT, FLANGE	2			
11	95827-06030	TORNILLO BOLT, FLANGE	4			
12	21C-F4188-10	MOLDURA DEPOSITO COMBUST. MOLD, FUEL TANK	2			
13	45D-F171A-00-33	CUBIERTA, TECHO COVER, TOP	1			YB YB
14	21C-F4141-00	PROTECTOR DEPOSITO COMBUST. PROTECTOR, FUEL TANK	1			
15	21C-F414A-00	CUBIERTA DE LLENADOR COVER, FILLER	1			
16	21C-F4318-00	TUBO DE REBOSAMIENTO PIPE, OVERFLOW	1			
17	21C-F4614-00-P0	PLACA DE TAPA PLATE, CAP	1			S8 S8
18	90159-05065	TORNILLO CON VALONA SCREW, WITH WASHER	3			
19	90179-05523	TUERCA NUT	3			
20	21C-WF461-10	TAPA DE DEPOSITO COMPLETO CAP ASSY WITH LOCK	1			
21	21C-F4500-10	GRIFO DE COMBUSTIBLE 1 FUEL COCK ASSY 1	1			
22	54B-F4512-10	.EMPAQUE .GASKET	1			
23	54B-F4514-10	.RED DE FILTRO 1 .NET, FILTER 1	1			
24	54B-F4521-10	.COPA DE FILTRO .CUP, FILTER	1			
25	54B-F4564-10	.EMPAQUE .GASKET	1			
26	54B-F4598-10	.PERILLA .KNOB	1			
27	54B-F4535-10	.TORNILLO ACCESORIO DE PALANCA .SCREW, LEVER FITTING	1			





FIG. 24 DEPOSITO DE COMBUSTIBLE 2 FUEL TANK 2



REF. Nº	CODIGO Nº PART NO.	DESCRIPCION DESCRIPTION	45D3			OBSERVACIONES REMARKS
1	45D-F4129-00-33	CUBIERTA LATERAL 1 COVER, SIDE 1	1			UR PARA YB UR FOR YB
	45D-F4129-00-P0	CUBIERTA LATERAL 1 COVER, SIDE 1	1			UR PARA DRMK UR FOR DRMK
	45D-F4129-00-P1	CUBIERTA LATERAL 1 COVER, SIDE 1	1			UR PARA BMC UR FOR BMC
	45D-F4129-00-P2	CUBIERTA LATERAL 1 COVER, SIDE 1	1			UR PARA YRC2 UR FOR YRC2
2	21C-F476U-00	PROTECTOR PROTECTOR,1	1			
3	45D-F4139-00-33	CUBIERTA LATERAL 2 COVER, SIDE 2	1			UR PARA YB UR FOR YB
	45D-F4139-00-P0	CUBIERTA LATERAL 2 COVER, SIDE 2	1			UR PARA DRMK UR FOR DRMK
	45D-F4139-00-P1	CUBIERTA LATERAL 2 COVER, SIDE 2	1			UR PARA BMC UR FOR BMC
	45D-F4139-00-P2	CUBIERTA LATERAL 2 COVER, SIDE 2	1			UR PARA YRC2 UR FOR YRC2
4	21C-F476V-00	PROTECTOR2 PROTECTOR,2	1			
5	21C-F414H-10	EQUILIBRIO, CUBIERTA DAMPER, PLATE 1	4			
6	90480-13398	TAPON GROMMET	2			
7	90111-05003	TORNILLO BOLT,HEX. SOCKET BUTTON	8			
8	90202-05180	ARANDELA DE PLANA WASHER, PLATE	8			
9	90183-05061	TUERCA DE RESORTE NUT, SPRING	8			
10	90159-05065	TORNILLO CON VALONA SCREW, WITH WASHER	2			
11	90179-05523	TUERCA NUT	2			
12	45D-F137U-10-33	GUIA DE AIRE 1 GUIDE, AIR 1	1			UR PARA YB UR FOR YB
	45D-F137U-10-P0	GUIA DE AIRE 1 GUIDE, AIR 1	1			UR PARA DRMK UR FOR DRMK
	45D-F137U-10-P2	GUIA DE AIRE 1 GUIDE, AIR 1	1			UR PARA BMC UR FOR BMC
	45D-F137U-10-P1	GUIA DE AIRE 1 GUIDE, AIR 1	1			UR PARA YRC2 UR FOR YRC2
13	45D-F137V-10-33	GUIA DE AIRE 2 GUIDE, AIR 2	1			UR PARA YB UR FOR YB
	45D-F137V-10-P0	GUIA DE AIRE 2 GUIDE, AIR 2	1			UR PARA DRMK UR FOR DRMK
	45D-F137V-10-P2	GUIA DE AIRE 2 GUIDE, AIR 2	1			UR PARA BMC UR FOR BMC
	45D-F137V-10-P1	GUIA DE AIRE 2 GUIDE, AIR 2	1			UR PARA YRC2 UR FOR YRC2
14	97707-50012	TORNILLO SCREW, TRUSS HEAD TAPPING	4			
15	90183-05042	TUERCA DE RESORTE NUT, SPRING	4			

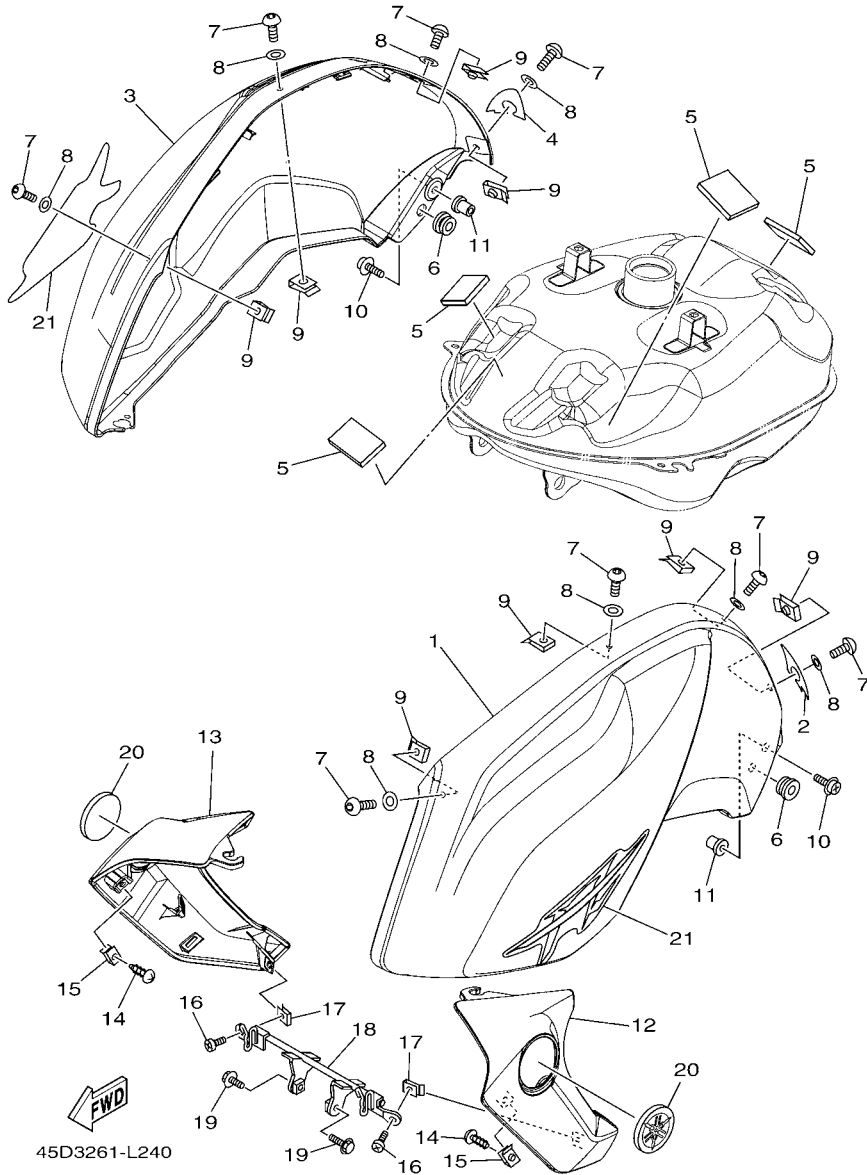


FIG. 24 DEPOSITO DE COMBUSTIBLE 2 FUEL TANK 2

REF. N°	CODIGO N° PART NO.	DESCRIPCION DESCRIPTION	45D3				OBSERVACIONES REMARKS
16	98507-05010	TORNILLO DE CABEZA CON PLANA SCREW, PAN HEAD	2				
17	90183-05076	TUERCA DE RESORTE NUT, SPRING	2				
18	45D-F4216-00	SOPORTE STAY	1				
19	95827-06012	TORNILLO BOLT, FLANGE	2				
20	22P-F413B-00	EMBLEMA EMBLEM	2				
21	45D-F4245-00	CALCOMANIA DEPOSITO COMBUST.2 GRAPHIC, FUEL TANK 2	2				UR PARA YB UR FOR YB
	45D-F4245-10	CALCOMANIA DEPOSITO COMBUST.2 GRAPHIC, FUEL TANK 2	2				UR PARA DRMK UR FOR DRMK
	45D-F4245-20	CALCOMANIA DEPOSITO COMBUST.2 GRAPHIC, FUEL TANK 2	2				UR PARA BMC UR FOR BMC
	45D-F4245-30	CALCOMANIA DEPOSITO COMBUST.2 GRAPHIC, FUEL TANK 2	2				UR PARA YRC2 UR FOR YRC2

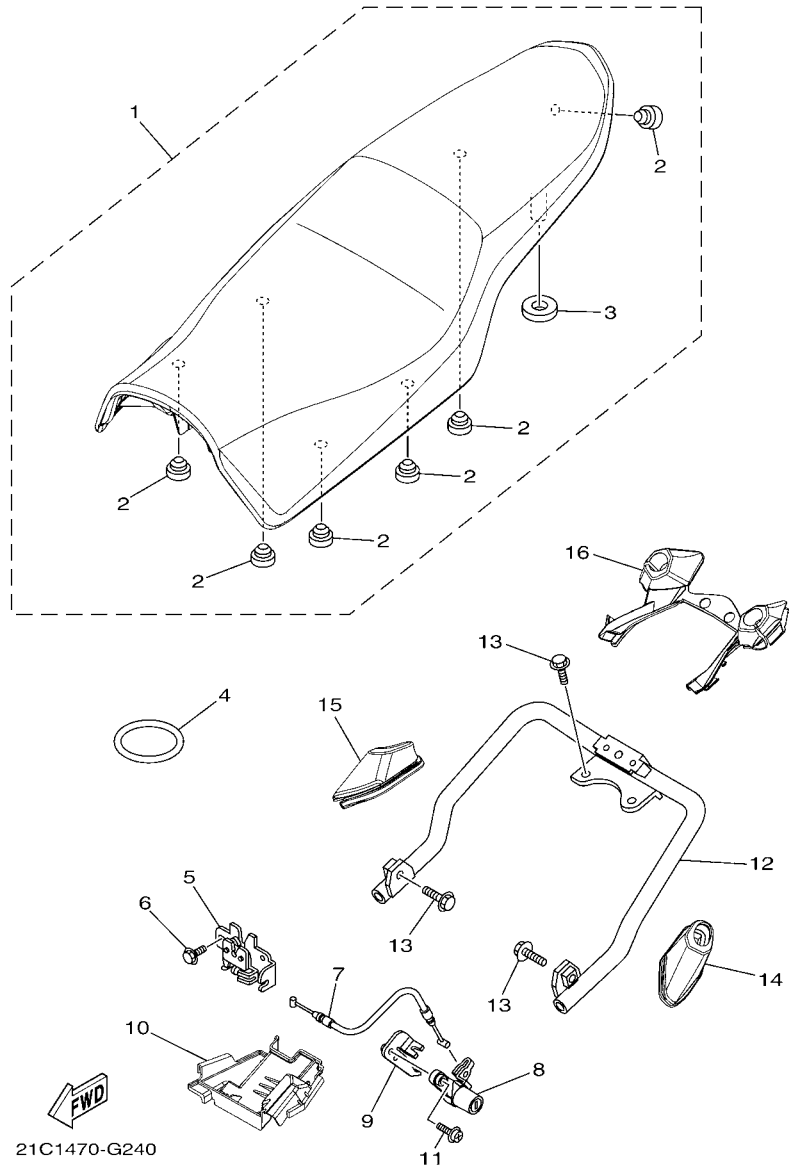


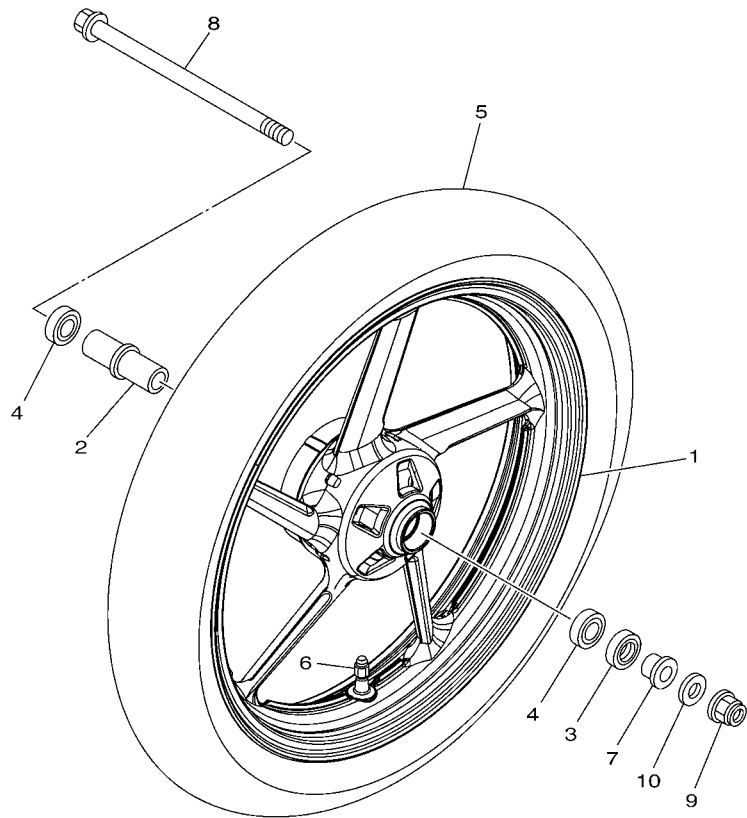
FIG. 25 ASIENTO

SEAT

REF. N°	CODIGO N° PART NO.	DESCRIPCION DESCRIPTION	45D3				OBSERVACIONES REMARKS
1	1EP-F4730-01	SILLIN DOBLE COMPLETO DOUBLE SEAT ASSY	1				
2	45D-F4741-00	.COJIN DE ASIENTO .PAD, SEAT	6				
3	45D-F4763-00	.COJIN DE ASIENTO 2 .PAD, SEAT 2	1				
4	20P-H2131-00	TIRANTE DE BATERIA BAND, BATTERY	1				
5	21C-F4780-01	CERRADURA SILLIN COMPLETO SEAT LOCK ASSY	1				
6	95027-06010	PERNO, DE BRIDA BOLT, FLANGE	2				
7	21C-F478E-01	CABLE CABLE, SEAT LOCK	1				
8	21C-WF479-00	CUBIERTA, DE COLA ROTOR SUB ASSY WITH KEY	1				
9	21C-F117K-00	SOPORTE DE CERRADURA STAY, LOCK	1				
10	21C-F472T-10	CUBIERTA, ASIENTO DE CIERRE COVER, SEAT LOCK	1				
11	90159-06033	TORNILLO CON VALONA SCREW, WITH WASHER	1				
12	45D-F4773-00	MANIJA DE ASIENTO HANDLE, SEAT	1				
13	95827-08016	TORNILLO BOLT, FLANGE	4				
14	21C-F479T-00	FUNDA 1, ASIENTO DE MANUBRIO BOOT, HANDLE SEAT 1	1				
15	21C-F479U-00	FUNDA 2, ASIENTO DE MANUBRIO BOOT, HANDLE SEAT 2	1				
16	21C-F479V-00	FUNDA 3, ASIENTO DE MANUBRIO BOOT, HANDLE SEAT 3	1				

FIG. 26 RUEDA DELANTERA

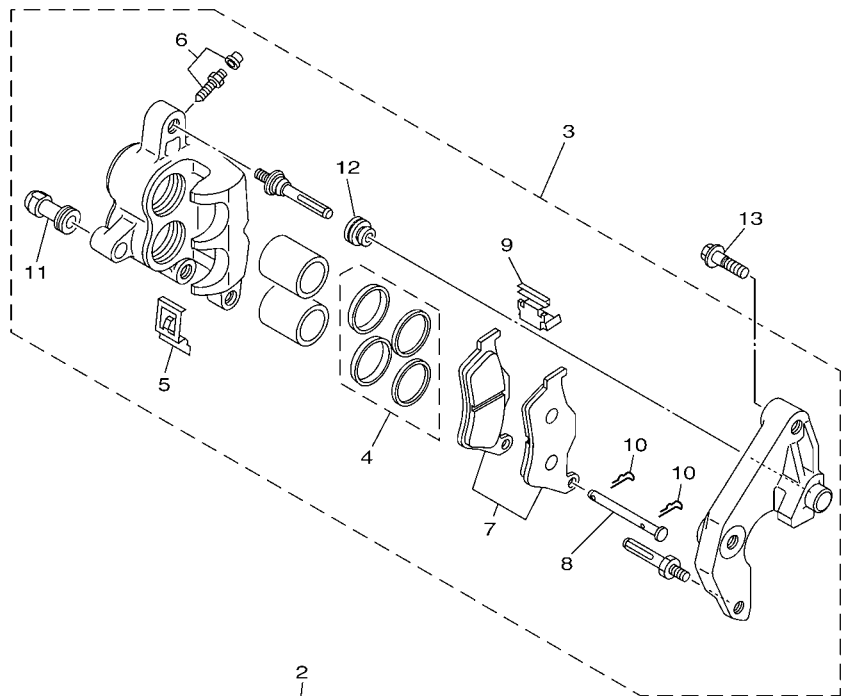
FRONT WHEEL



**FWD**  
21C1470-G250

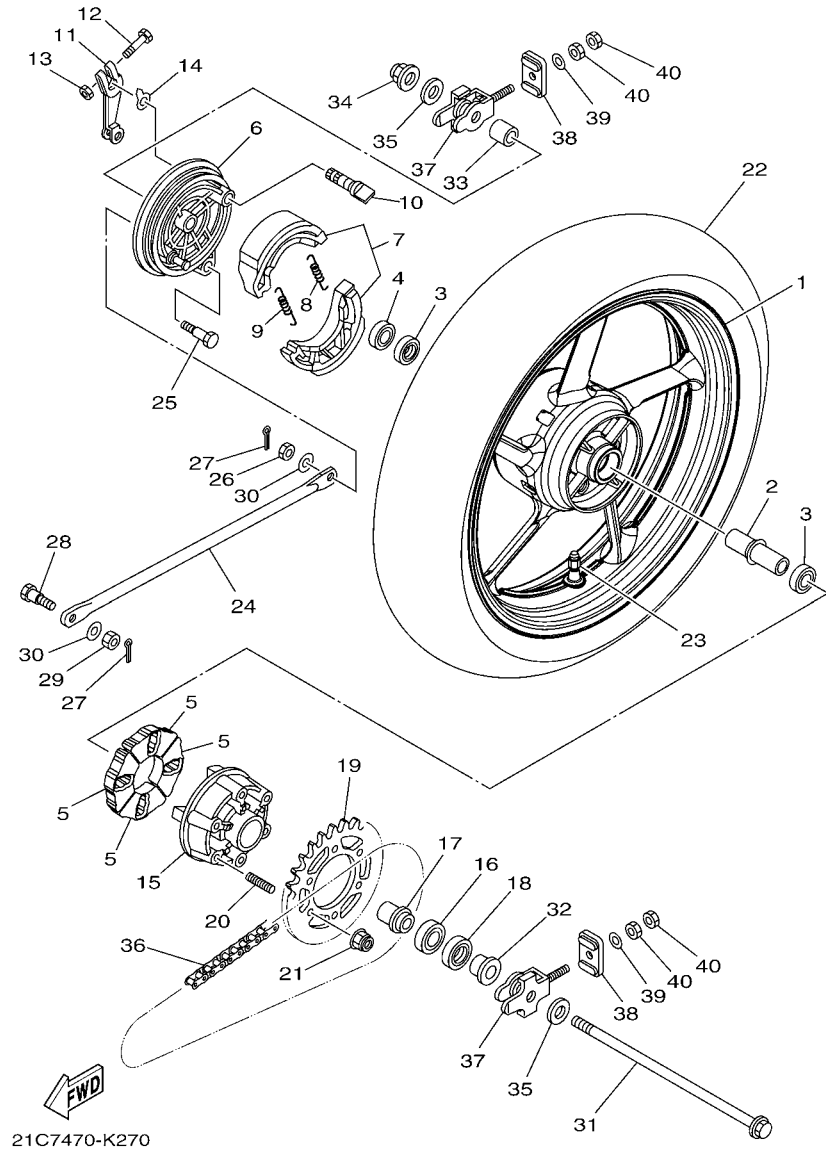
REF. N°	CODIGO N° PART NO.	DESCRIPCION DESCRIPTION	46D3				OBSERVACIONES REMARKS
1	21C-F5168-10-33	RUEDA FUNDIDA DELANTERA CAST WHEEL, FRONT	1				YB YB
2	21C-F510C-10	COLLAR COLLAR ASSY.	1				
3	93106-22808	SELLO ACEITE OIL SEAL	1				
4	93306-252XG	COJINETE BEARING	2				
5	94110-17804	NEUMATICO(100/80-17 MC 52P) TIRE (100/80-17 MC 52P)	1				MRF MRF
6	93900-00824	VALVULA VALVE, RIM TR413	1				
7	21C-F5183-01	COLLAR DE RUEDA COLLAR, WHEEL	1				
8	21C-F5181-00	EJE DE LA RUEDA AXLE, WHEEL	1				
9	95607-14200	TUERCA DE AUTO-CIERRE NUT, SELF-LOCKING	1				
10	90201-142M6	ARANDELA PLANA WASHER, PLATE	1				

**FIG. 27 CALIBRE FRENO DELANTERA FRONT BRAKE CALIPER**



21C1470-G260

REF. Nº	CODIGO Nº PART NO.	DESCRIPCION DESCRIPTION	45D3				OBSERVACIONES REMARKS
1	21C-F582U-00	DISCO DE FRENO (DERECHO) DISK, BRAKE (RIGHT)	1				
2	90111-08847	TORNILLO BOLT, HEX. SOCKET BUTTON	5				
3	5YY-F580U-20	CALIBRE COMPLETO (DERECHO) CALIPER ASSY (RIGHT)	1				
4	5US-W0047-00	JUEGO DE RETENES DE PINZA CALIPER SEAL KIT	1				
5	5US-F5977-00	RESORTE DE RETORNO SPRING, RETURN	1				
6	5US-W0048-00	CJTO TORNILLO DE PURGA BLEED SCREW KIT	1				
7	5US-W0045-00	JUEGO DE COJIN DE FRENO BRAKE PAD KIT	1				
8	5US-F5744-00	PASADOR 2 PIN 2	1				
9	5US-F5827-00	CUNA DE CALIBRE SHIM, CALIPER	1				
10	5US-W0016-00	PRESILLA CLIP	1				
11	5US-W0068-00	AISLANTE INSULATOR	1				
12	5US-W0053-00	DUST COVER DUST COVER	1				
13	90105-10319	TORNILLO BOLT, FLANGE	2				



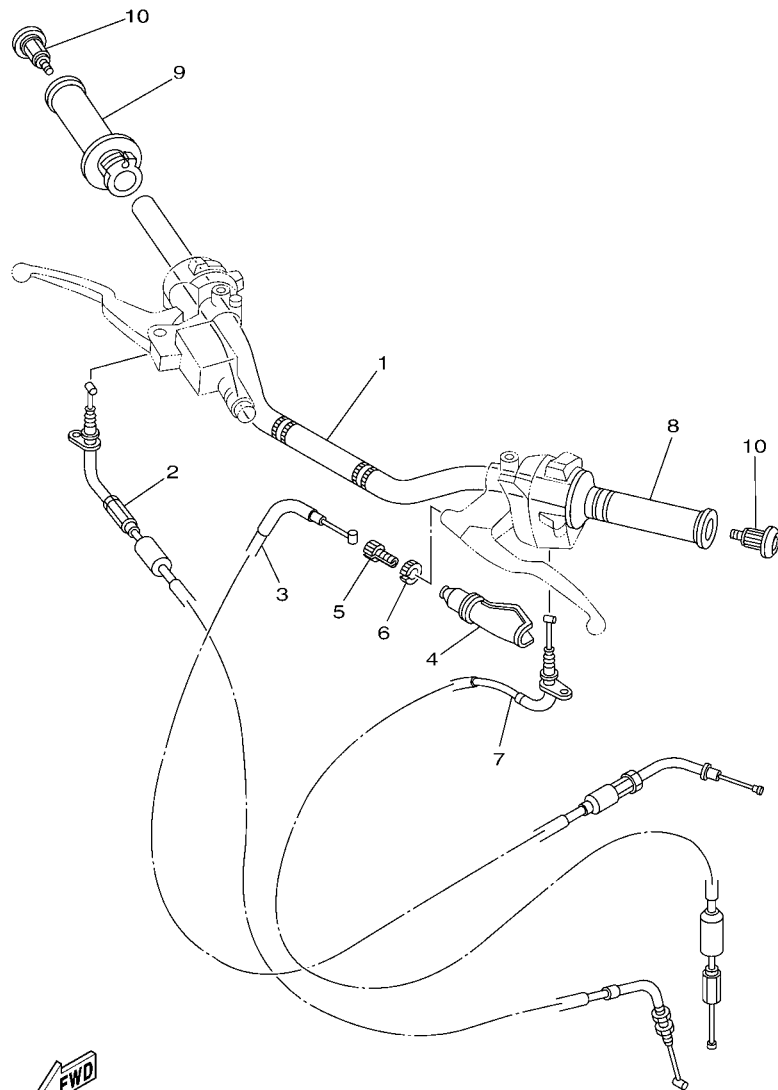
21C7470-K270

FIG. 28 RUEDA TRASERA

REAR WHEEL

REF. N°	CODIGO N° PART NO.	DESCRIPCION DESCRIPTION	45D3			OBSERVACIONES REMARKS
1	21C-F5338-10-33	RUEDA FUNDIDA TRASERA CAST WHEEL, REAR	1			YB YB
2	21C-F530S-10	ASAMBLA DE COLLAR COLLAR ASSY	1			
3	93306-252XG	COJINETE BEARING	2			
4	93106-22808	SELLO ACEITE OIL SEAL	1			
5	21C-F5364-00	AMORTIGUADOR DAMPER	4			
6	5US-F5321-10	PLACA DE ZAPATA DE FRENO PLATE, BRAKE SHOE	1			
7	5YY-WF533-00	JUEGO DE ZAPATA DE FRENO BRAKE SHOE KIT	1			
8	90506-12001	RESORTE DE TENSION SPRING, TENSION	1			
9	90506-15001	RESORTE DE TENSION SPRING, TENSION	1			
10	5YY-F5351-00	ARBOL DE LEVAS CAMSHAFT	1			
11	21C-F5355-01	PALANCA DE ARBOL DE LEVAS LEVER, CAMSHAFT	1			
12	90101-06046	TORNILLO BOLT	1			
13	95307-06600	TUERCA NUT	1			
14	36L-F533A-00	PLACA INDICADOR PLATE, INDICATOR	1			
15	20P-F5366-00-33	EMBRAGUE DE MASA CLUTCH, HUB	1			YB YB
16	93306-054Y5	COJINETE BEARING	1			
17	20P-F5377-00	COLLAR DE RUEDA COLLAR, WHEEL	1			
18	93106-26801	SELLO ACEITE OIL SEAL	1			
19	45D-F5440-00	CORONA (40T) SPROCKET, DRIVEN (40T)	1			
20	90116-08552	ESPARRAGO BOLT, STUD	6			
21	95602-08200	TUERCA DE AUTO-CIERRE NUT, SELF-LOCKING	6			
22	94114-17800	NEUMATICO(140/60-17 MC 63P) TIRE (140/60-17 MC 63P)	1			MRF MRF
23	93900-00824	VALVULA VALVE, RIM TR413	1			
24	45D-F5371-00	BARRA TENSORA BAR, TENSION	1			
25	90109-08063	PERNO BOLT	1			
26	95307-08700	TUERCA NUT	1			
27	91401-20012	CHAVETA PIN, COTTER	2			





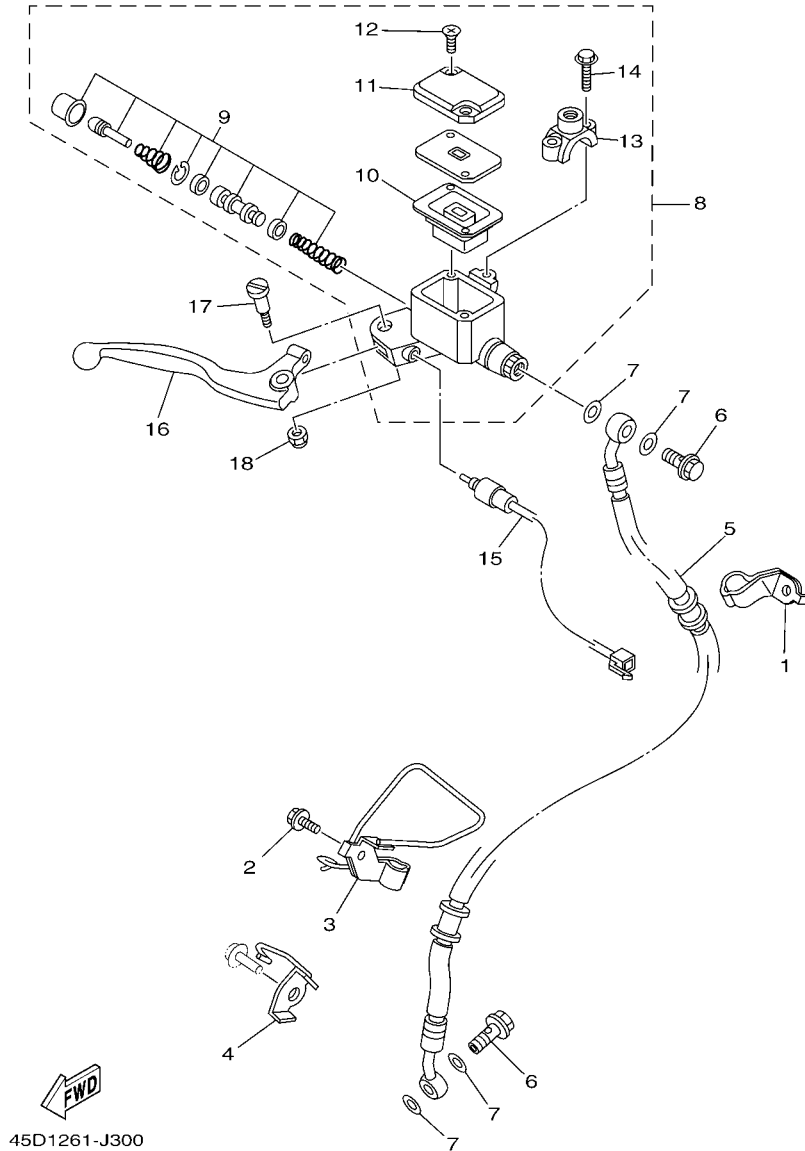
  
 45D1261-J290

FIG. 29 MANILLAR & CABLE

STEERING HANDLE & CABLE

REF. Nº	CODIGO Nº PART NO.	DESCRIPCION DESCRIPTION	45D3				OBSERVACIONES REMARKS
1	45D-F6111-00	MANUBRIO HANDLEBAR	1				
2	21C-F6311-10	CABLE DE ACELERADOR 1 CABLE, THROTTLE 1	1				
3	21C-F6335-00	CABLE DE EMBRAGUE CABLE, CLUTCH	1				
4	5TS-F6372-00	CUBIERTA DE PALANCA DE MANUB 1 COVER, HANDLE LEVER 1	1				
5	90123-08046	PERNO BOLT	1				
6	90179-08148	TUERCA NUT	1				
7	21C-F6331-01	CABLE DE ARRANQUE CABLE, STARTER 1	1				
8	45D-F6241-00	EMPUNADURA GRIP	1				
9	45D-F6240-00	EMPUNADURA COMPLETA GRIP ASSY	1				
10	21C-F620B-20	EXTREMO DE EMPUNADURA END GRIP ASSY	2				

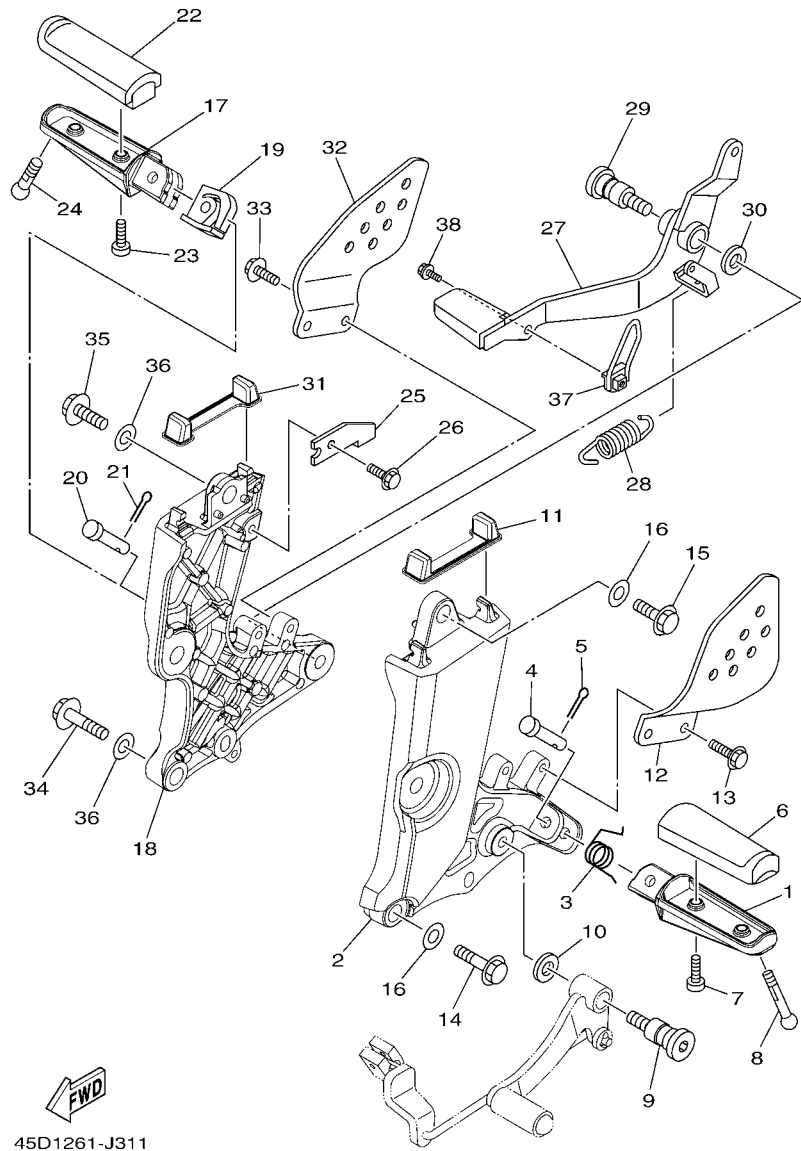




45D1261-J300

FIG. 30 CILINDRO MAESTRO DELANTERO FRONT MASTER CYLINDER

REF. N°	CODIGO N° PART NO.	DESCRIPCION DESCRIPTION	45D3				OBSERVACIONES REMARKS
1	21C-F5875-00	SOPORTE DE MANGUERA FRENO 1 HOLDER, BRAKE HOSE 1	1				
2	95827-06012	TORNILLO BOLT, FLANGE	1				
3	21C-F5876-00	SOPORTE DE MANGUERA FRENO 2 HOLDER, BRAKE HOSE 2	1				
4	21C-F3317-00	SOSTEN DE CABLE HOLDER, CABLE	1				
5	21C-F5872-00	MANGUERA DE FRENO 1 HOSE, BRAKE 1	1				
6	90401-10818	PERNO DE UNIÓN BOLT, UNION	2				
7	90201-10815	ARANDELA PLANA WASHER, PLATE	4				
8	21C-F583T-00	CILINDRO MAESTRO COMPLETO MASTER CYLINDER ASSY	1				
9	5US-W0041-00	JUEGO DE CILINDRO MAESTRO .CYLINDER KIT, MASTER	1				
10	5US-25854-00	EMPAQUE, DIAFRAGMA .DIAPHRAGM, RESERVOIR	1				
11	5US-25852-00	TAPA DE TANQUE DE RESERVA .CAP, RESERVOIR	1				
12	98706-04012	TORNILLO DE CABEZA PLANA .SCREW, FLAT HEAD	2				
13	5YY-F5867-00	SOPORTE DE CILINDRO MAESTRO .BRACKET, MASTER CYLINDER	1				
14	90105-06859	TORNILLO .BOLT, FLANGE	2				
15	21C-H3980-00	INTERRUP. DE PARADA DELANTERO FRONT STOP SWITCH ASSY	1				
16	5YY-H3922-01	PALANCA 2 LEVER 2	1				
17	90109-06859	PERNO BOLT	1				
18	90185-06802	TUERCA AUTOBLOCANTE NUT, SELF-LOCKING	1				



45D1261-J311

FIG. 31 SOPORTE & APOYAPIE

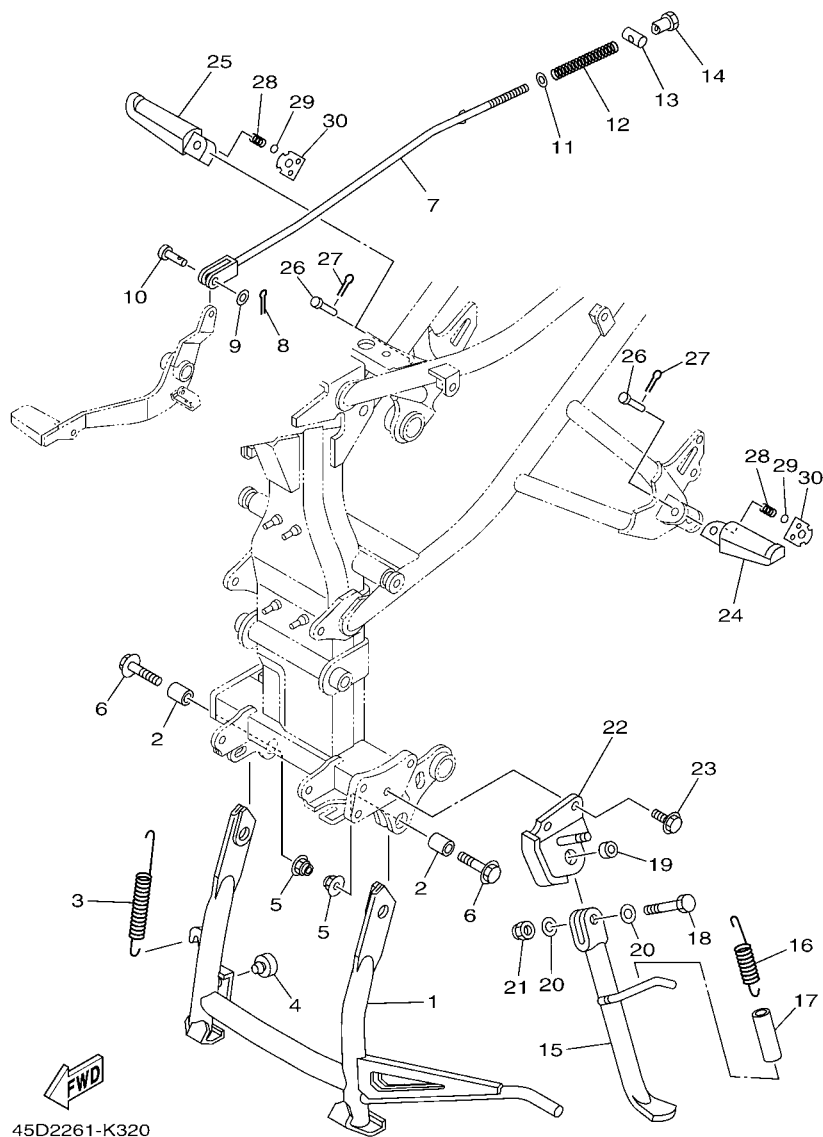
STAND & FOOTREST

REF. Nº	CODIGO Nº PART NO.	DESCRIPCION DESCRIPTION	45D3			OBSERVACIONES REMARKS
1	35B-F7451-00	APOYAPIE FOOTREST	1			
2	21C-F7452-00-P0	SOPORTE, DE APOYAPIE 1 BRACKET, FOOTREST 1	1			S8
3	90508-183B9	RESORTE DE TORSION SPRING, TORSION	1			S8
4	91701-08040	PASADOR DE ABRAZADERA PIN	1			
5	91401-25015	CHAVETA PIN, COTTER	1			
6	21C-F7413-00	CUBIERTA DE APOYAPIE COVER, FOOTREST	1			
7	98507-05014	TORNILLO DE CABEZA PLANA SCREW, PAN HEAD	2			
8	90109-08202	PERNO BOLT	1			
9	21C-27261-01	EJE SHAFT	1			
10	90201-10021	ARANDELA PLANA WASHER, PLATE	1			
11	21C-F7414-00	AMORTIGUADOR DE APOYAPIE DAMPER, FOOTREST	1			
12	21C-F7445-01	PLACE 1 PLATE 1	1			
13	95812-06014	TORNILLO DE REBORDE BOLT, FLANGE	2			
14	95817-08035	TORNILLO BOLT, FLANGE	2			
15	95817-08025	TORNILLO BOLT, FLANGE	1			
16	90201-08079	ARANDELA PLANA WASHER, PLATE	3			
17	35B-F7461-00	APOYAPIE FOOTREST	1			S8
18	21C-F7462-00-P0	SOPORTE, DE APOYAPIE 2 BRACKET, FOOTREST 2	1			S8
19	21C-F7426-00	RESORTE DE RETORNO SPRING, RETURN	1			
20	91701-08040	PASADOR DE ABRAZADERA PIN	1			
21	91401-25015	CHAVETA PIN, COTTER	1			
22	21C-F7413-00	CUBIERTA DE APOYAPIE COVER, FOOTREST	1			
23	98507-05014	TORNILLO DE CABEZA PLANA SCREW, PAN HEAD	2			
24	90109-08202	PERNO BOLT	1			
25	21C-F144G-00	SOPORTE DE INTERRUPTOR STAY, STOP SWITCH	1			
26	95807-06010	TORNILLO BOLT, FLANGE	1			
27	45D-F7211-00	PEDAL DE FRENO PEDAL, BRAKE	1			



FIG. 32 SOPORTE & APOYAPIE 2

STAND & FOOTREST 2

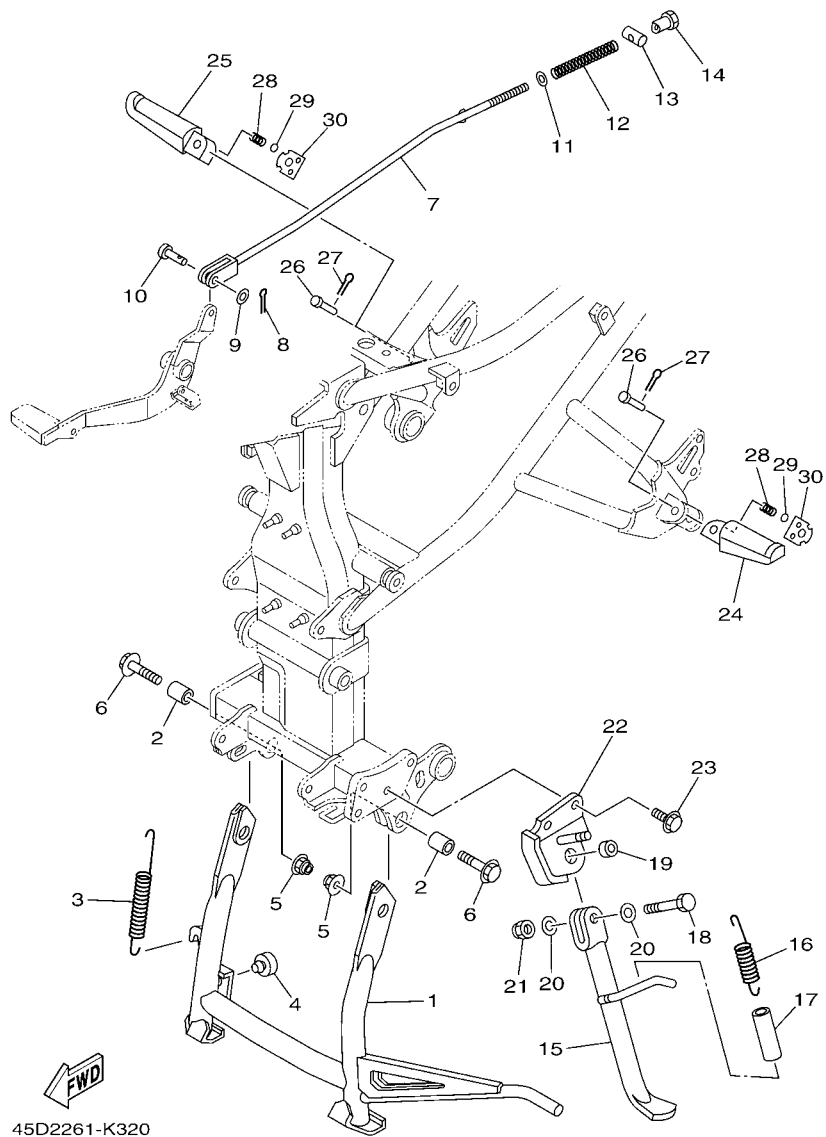


45D2261-K320

REF. Nº	CODIGO Nº PART NO.	DESCRIPCION DESCRIPTION	45D3				OBSERVACIONES REMARKS
1	1EP-F7111-00	PUNTAL PRINCIPAL STAND, MAIN	1				
2	90387-10822	ESPACIADOR COLLAR	2				
3	90506-35816	RESORTE DE TENSION SPRING, TENSION	1				
4	21C-F7114-00	TOPE DE PUNTAL PRINCIPAL STOPPER, MAIN STAND	1				
5	95607-10200	TUERCA DE AUTO-CIERRE NUT, U FLANGE	2				
6	90105-10009	TORNILLO BOLT, FLANGE	2				
7	21C-F7231-00	VARILLA DE FRENO ROD, BRAKE	1				
8	91401-20012	CHAVETA PIN, COTTER	1				
9	92907-06200	ARANDELA WASHER	1				
10	90240-06804	PASADOR CON HOYO PIN, CLEVIS	1				
11	92907-06200	ARANDELA WASHER	1				
12	90501-10245	RESORTE DE COMPRESION SPRING, COMPRESSION	1				
13	90249-12008	PASADOR PIN	1				
14	90179-06018	TUERCA NUT	1				
15	45D-F7311-00	PUNTAL LATERAL STAND, SIDE	1				
16	90506-23807	RESORTE DE TENSION SPRING, TENSION	1				
17	90445-13806	TUBO HOSE	1				
18	90101-10006	TORNILLO BOLT	1				
19	90387-10003	ESPACIADOR COLLAR	1				
20	90201-101J1	ARANDELA PLANA WASHER, PLATE	2				
21	90185-10091	TUERCA AUTOBLOCANTE NUT, SELF-LOCKING	1				
22	21C-F7321-01	SOPORTE DE PUNTAL LATERAL BRACKET, SIDE STAND	1				
23	95027-10025	PERNO, DE BRIDA BOLT, FLANGE	2				
24	20P-F7431-00	APOYAPIE POSTERIOR 1 FOOTREST, REAR 1	1				
25	20P-F7441-00	APOYAPIE POSTERIOR 2 FOOTREST, REAR 2	1				
26	91701-08035	PASADOR DE ABRAZADERA PIN	2				
27	91401-25015	CHAVETA PIN, COTTER	2				

FIG. 32 SOPORTE & APOYAPIE 2

STAND & FOOTREST 2

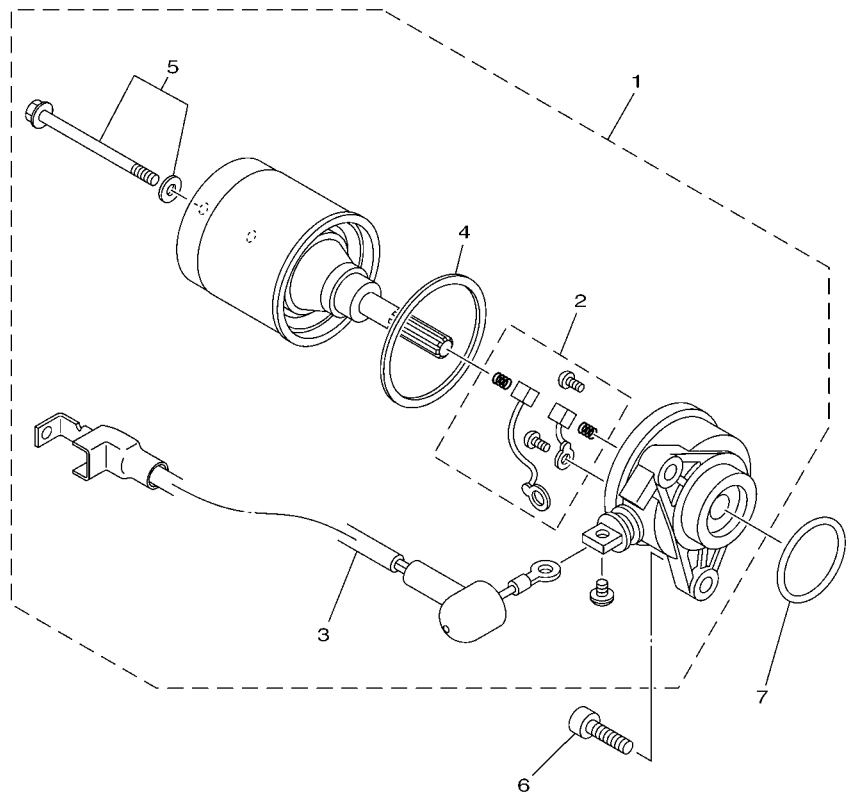


REF. Nº	CODIGO Nº PART NO.	DESCRIPCION DESCRIPTION	45D3				OBSERVACIONES REMARKS
28	90501-12743	RESORTE DE COMPRESION SPRING, COMPRESSION	2				
29	93501-04805	BOLA BALL	2				
30	35B-F7437-00	ARANDELA ESPECIAL WASHER, SPECIAL	2				
-----							
-----							
-----							
-----							
-----							
-----							
-----							
-----							
-----							



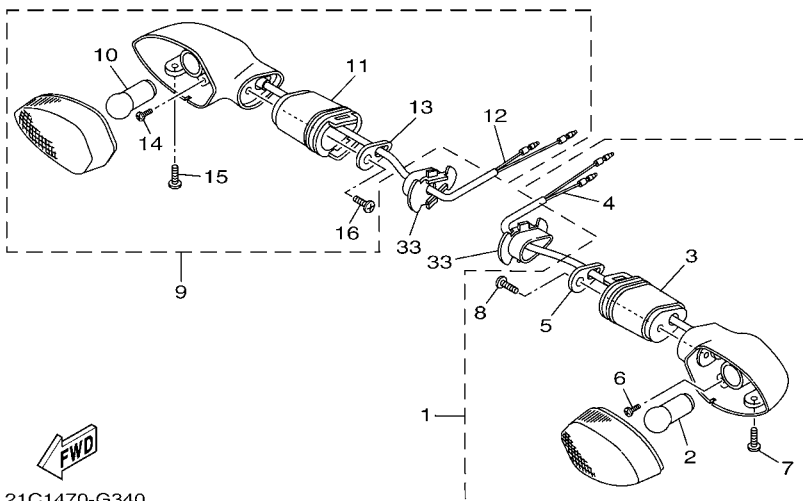
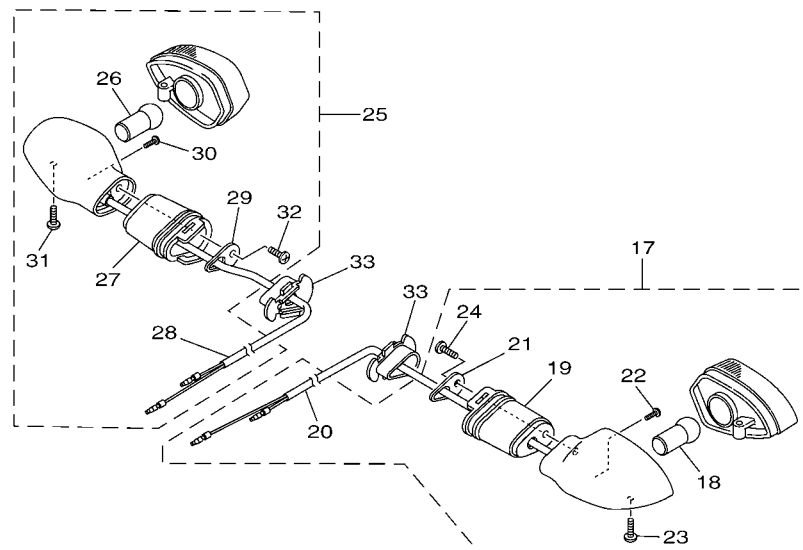
FIG. 34 MOTOR DE ARRANQUE

STARTING MOTOR



REF. Nº	CODIGO Nº PART NO.	DESCRIPCION DESCRIPTION	45D3				OBSERVACIONES REMARKS
1	21C-H1800-10	MOTOR DE ARRANQUE COMPLETO STARTING MOTOR ASSY	1				
2	5TP-H1801-00	.JUEGO DE ESCOBILLA .BRUSH SET	1				
3	21C-H183G-00	.CABLE DEL MOTOR COMPL. .CORD COMP.	1				
4	5D9-H1861-00	.EMPAQUETADURA .GASKET	1				
5	5D9-H1828-00	.TORNILLO DE EMPUJE 2 .SCREW 2	2				
6	91312-06020	TORNILLO BOLT	2				
7	93210-29807	ANILLO O O-RING	1				

  
21C7470-K330



21C1470-G340

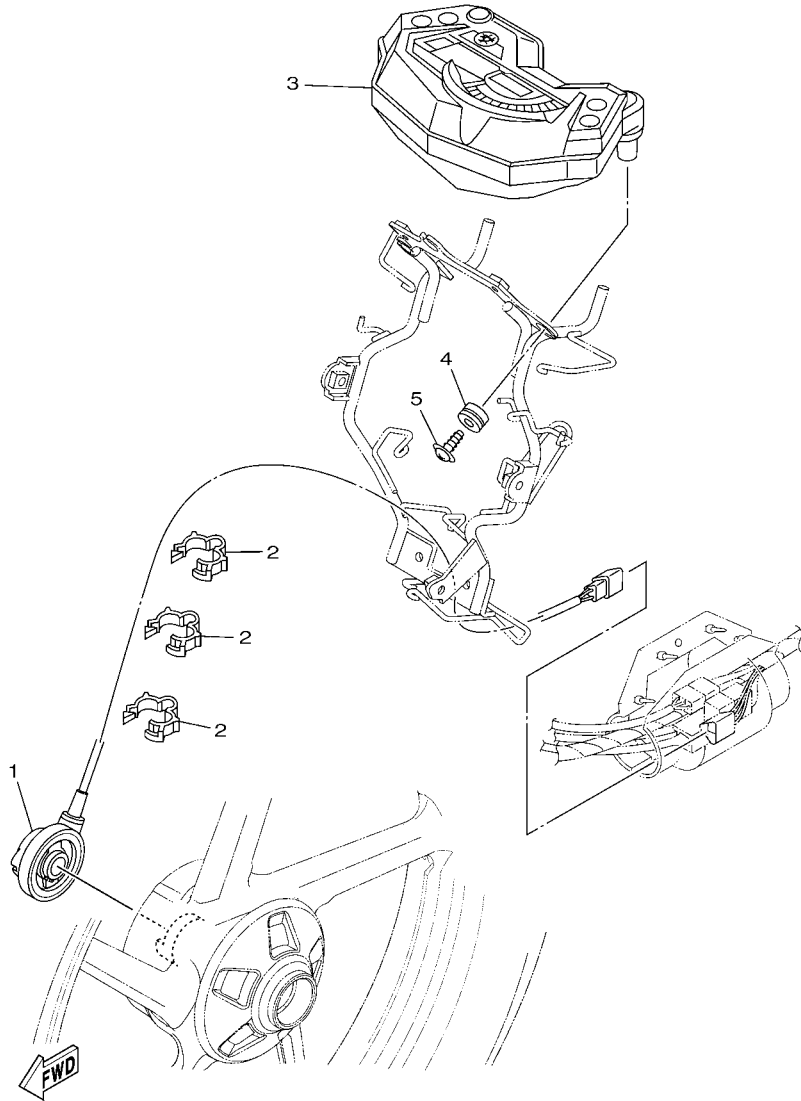
FIG. 35 LUZ DE DESTELLADOR

FLASHER LIGHT

REF. Nº	CODIGO Nº PART NO.	DESCRIPCION DESCRIPTION	45D3				OBSERVACIONES REMARKS
1	21C-H3310-00	DESTELLADOR DE LUZ DELANT. FRONT FLASHER LIGHT ASSY 1	1				
2	21C-H3311-00	.BOMBILLA (12V-10W) .BULB, FLASHER (12V-10W)	1				
3	20P-H3318-10	.SOPORTE DE DESTELLADOR 1 .STAY, FLASHER 1	1				
4	21C-H331E-00	.CORDON COMPLETO .CORD ASSY	1				
5	20P-H3618-00	.PLACA .PLATE	1				
6	20P-H213A-00	.TORNILLO ACCESORIO .SCREW, FITTING	1				
7	20P-H3333-00	.TORNILLO ACCESORIO DE LENTE .SCREW, LENS FITTING	1				
8	20P-H2133-00	.TORNILLO ACCESORIO .SCREW, FITTING	1				
9	21C-H3320-00	DESTELLADOR DE LUZ DELANT. FRONT FLASHER LIGHT ASSY 2	1				
10	21C-H3311-00	.BOMBILLA (12V-10W) .BULB, FLASHER (12V-10W)	1				
11	20P-H3318-10	.SOPORTE DE DESTELLADOR 1 .STAY, FLASHER 1	1				
12	21C-H332E-00	.CABLE COMPL. .CORD ASSY	1				
13	20P-H3618-00	.PLACA .PLATE	1				
14	20P-H213A-00	.TORNILLO ACCESORIO .SCREW, FITTING	1				
15	20P-H3333-00	.TORNILLO ACCESORIO DE LENTE .SCREW, LENS FITTING	1				
16	20P-H2133-00	.TORNILLO ACCESORIO .SCREW, FITTING	1				
17	21C-H3330-00	DESTELLADOR DE LUZ TRAS.COMPL. REAR FLASHER LIGHT ASSY 1	1				
18	21C-H3311-00	.BOMBILLA (12V-10W) .BULB, FLASHER (12V-10W)	1				
19	20P-H3318-00	.SOPORTE DE DESTELLADOR 1 .STAY, FLASHER 1	1				
20	21C-H355M-00	.CORDON COMPLETO .CORD ASSY	1				
21	20P-H3618-00	.PLACA .PLATE	1				
22	20P-H213A-00	.TORNILLO ACCESORIO .SCREW, FITTING	1				
23	20P-H3333-00	.TORNILLO ACCESORIO DE LENTE .SCREW, LENS FITTING	1				
24	20P-H2133-00	.TORNILLO ACCESORIO .SCREW, FITTING	1				
25	21C-H3340-00	DESTELLADOR DE LUZ TRAS.COMPL. REAR FLASHER LIGHT ASSY 2	1				
26	21C-H3311-00	.BOMBILLA (12V-10W) .BULB, FLASHER (12V-10W)	1				
27	20P-H3318-00	.SOPORTE DE DESTELLADOR 1 .STAY, FLASHER 1	1				







45D2261-K360

FIG. 36 MEDIDOR

METER

REF. N°	CODIGO N° PART NO.	DESCRIPCION DESCRIPTION	45D3				OBSERVACIONES REMARKS
1	21C-H3756-01	SENSOR, UNIDAD SENSOR, UNIT	1				
2	90464-14803	BRIDA CLAMP	3				
3	45S-H3500-20	METRO COMPLETO METER ASSY	1				
4	90480-14818	TAPON GROMMET	3				
5	90160-05006	TORNILLO REDONDO ROSCA HEMBRA SCREW, ROUND TAPPING	3				
<hr/>							
<hr/>							
<hr/>							
<hr/>							
<hr/>							
<hr/>							
<hr/>							
<hr/>							

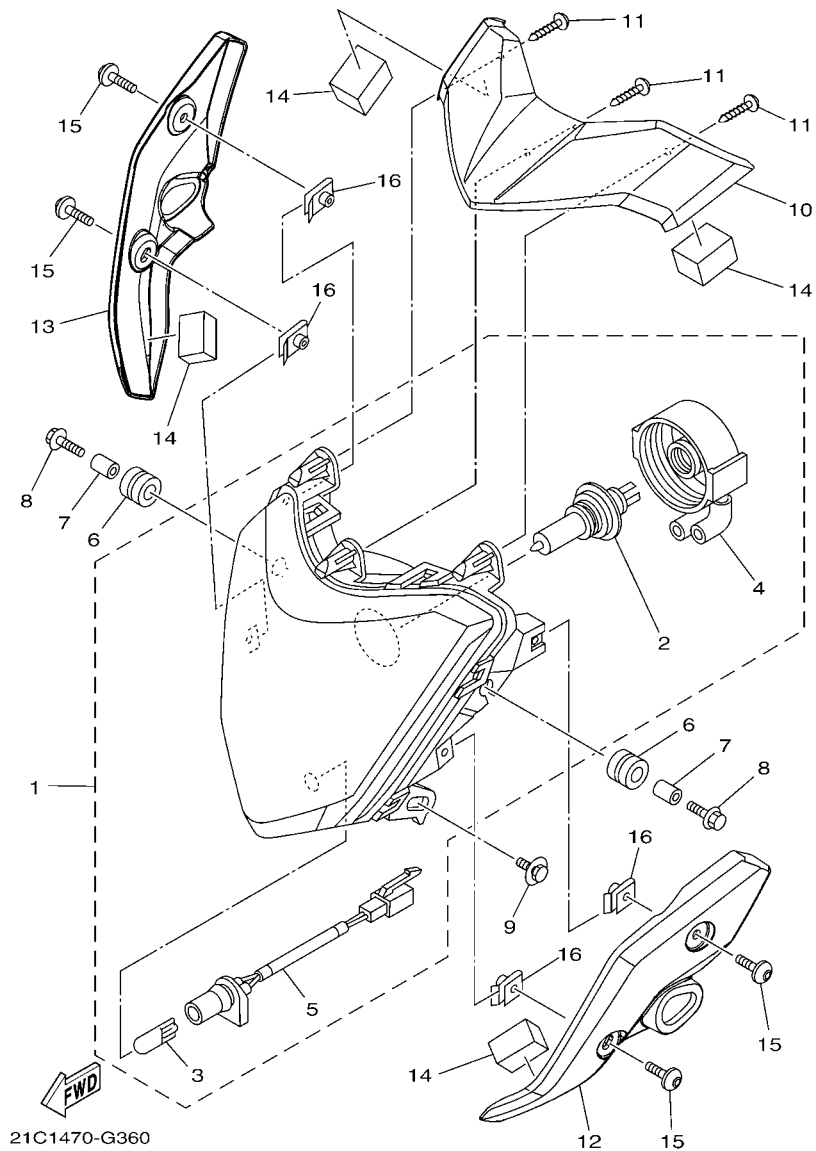


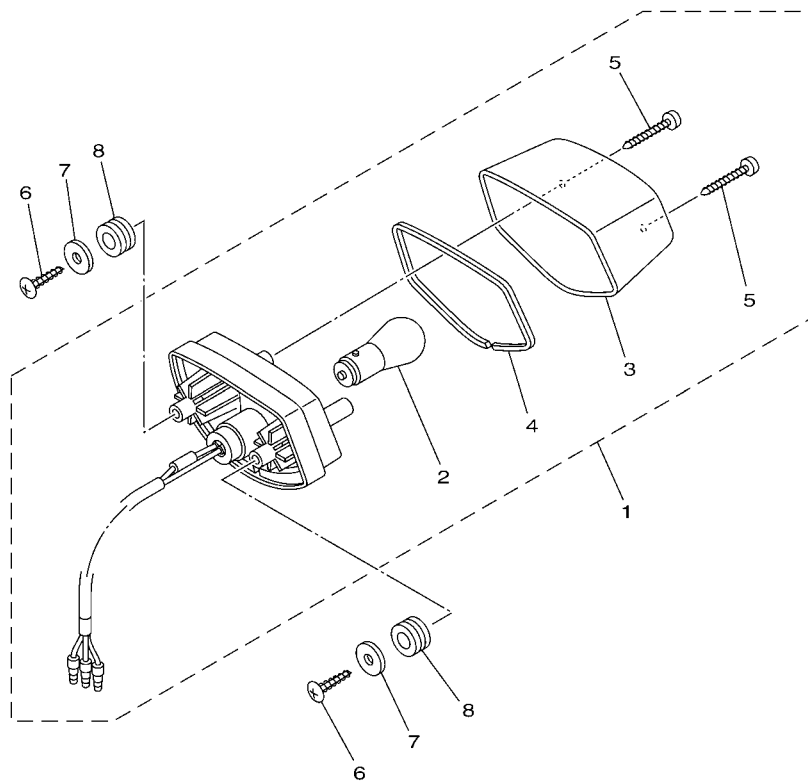
FIG. 37 FARO DELANTERO

HEADLIGHT

REF. N°	CODIGO N° PART NO.	DESCRIPCION DESCRIPTION	45D3			OBSERVACIONES REMARKS
1	1ES-H4300-00	FARO DELANTERO COMPLETO HEADLIGHT ASSY	1			
2	21C-H4314-00	.AMPOLLETA (12V-35/35W) .BULB (12V-35/35W)	1			
3	21C-H4347-00	.AMPOLLETA (12V-5W) .BULB (12V-5W)	1			
4	21C-H4502-00	.CUBIERTA COMPLETO .COVER COMP.	1			
5	21C-H4312-00	.CABLE COMPLETA .CORD ASSY	1			
6	90480-14101	TAPON GROMMET	2			
7	90387-068D4	ESPACIADOR COLLAR	2			
8	95807-06025	TORNILLO BOLT, FLANGE	2			
9	90119-06194	TORNILLO CON ARANDELA BOLT, WITH WASHER	1			
10	21C-F3121-20	CUBIERTA SUPERIOR 1 COVER, UPPER 1	1			
11	97707-40014	TORNILLO ROSCA HEMBRA SCREW, TAPPING	3			
12	21C-F3122-00-P0	CUBIERTA EXTERIOR 1 COVER, OUTER 1	1			S8
13	21C-F3132-00-P0	CUBIERTA EXTERIOR 2 COVER, OUTER 2	1			S8
14	21C-H4527-10	AMORTIGUADOR DAMPER	4			S8
15	90111-06121	TORNILLO BOLT, HEX. SOCKET BUTTON	4			
16	90183-061A4	TUERCA DE RESORTE NUT, SPRING	4			

FIG. 38 LUZ DE COLA

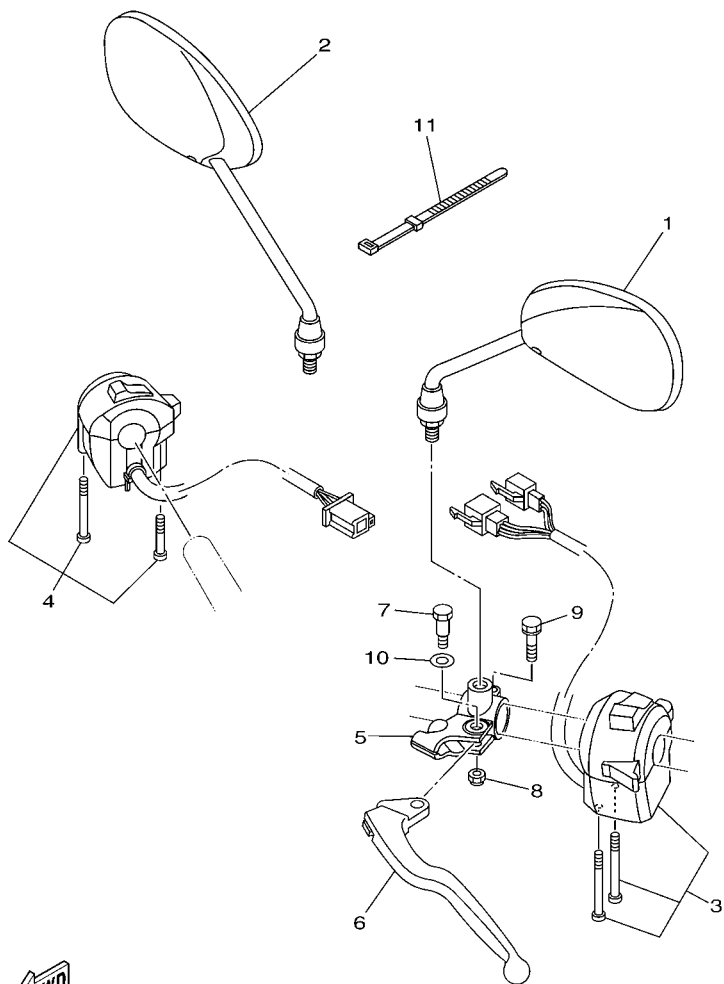
TAILLIGHT



  
21C1470-G370

REF. N°	CODIGO N° PART NO.	DESCRIPCION DESCRIPTION	45D3				OBSERVACIONES REMARKS
1	21C-H4710-00	UNIDAD FARO TRASERO COMPL. TAILLIGHT UNIT ASSY	1				
2	21C-H4714-00	.AMPOLLETA (12V-21/5W) .BULB (12V-21/5W)	1				
3	21C-H4721-00	.LENTE DE FARO TRASERO .LENS, TAILLIGHT	1				
4	21C-H4723-00	.EMPAQUE LENTE FARO TRASERO .GASKET, TAIL LENS	1				
5	97702-40030	.TORNILLO ROSCA HEMBRA .SCREW, TAPPING	2				
6	97707-50025	TORNILLO ROSCA HEMBRA SCREW, TAPPING	2				
7	90201-05036	ARANDELA PLANA WASHER, PLATE	2				
8	90480-14819	TAPON GROMMET	2				
-----							
-----							
-----							
-----							
-----							
-----							
-----							

**FIG. 39 INTERRUPTOR DE MANILLAR&PALANC HANDLE SWITCH & LEVER**

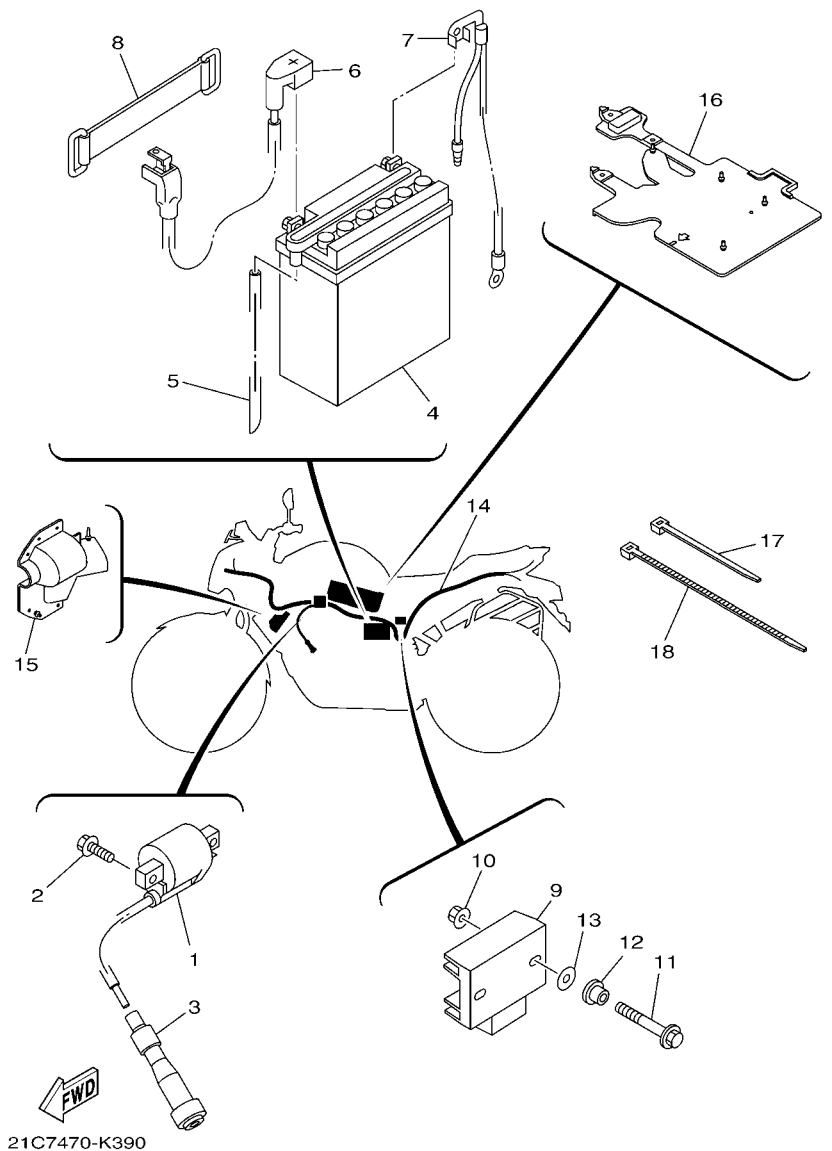


  
21C1470-G380

REF. Nº	CODIGO Nº PART NO.	DESCRIPCION DESCRIPTION	45D3				OBSERVACIONES REMARKS
1	21C-F6280-00	ESPEJO COMPLETO (IZQUIERDO) REAR VIEW MIRROR ASSY (LEFT)	1				
2	21C-F6290-00	ESPEJO COMPLETO (DERECHO) REAR VIEW MIRROR ASSY (RIGHT)	1				
3	21C-H3972-01	INTERRUPTOR DE MANIJA 4 SWITCH, HANDLE 4	1				
4	21C-H3963-01	INTERRUPTOR DE MANIJA 3 SWITCH, HANDLE 3	1				
5	5YY-H2911-00	SOPORTE DE LEVA 1 HOLDER, LEVER 1	1				
6	21C-H3912-00	PALANCA 1 LEVER 1	1				
7	36L-H3945-10	PERNO DE PALANCA BOLT, LEVER	1				
8	95707-06300	TUERCA DE BRIDA NUT, NYLON	1				
9	9750M-06425	PERNO CON ARANDELA BOLT, WITH WASHER	1				
10	90201-08834	ARANDELA PLANA WASHER, PLATE	1				
11	36L-H3936-00	BANDA DE CABLE DE INTERRUPTOR BAND, SWITCH CORD	2				
-----							
-----							
-----							
-----							
-----							

FIG. 40 EQUIPO ELECTRICO 1

ELECTRICAL 1



21C7470-K390

REF. Nº	CODIGO Nº PART NO.	DESCRIPCION DESCRIPTION	45D3				OBSERVACIONES REMARKS
1	45D-H2310-00	BOBINA DE ENCENDIDO COMPLETA IGNITION COIL ASSY	1				
2	95027-06020	PERNO, DE BRIDA BOLT, FLANGE	2				
3	20P-H2370-01	TAPON DE BUJIA COMPLT PLUG CAP ASSY	1				
4	3AY-H2110-00	BATERIA COMPLETA YB5L-B12V-5AH BATTERY ASSY (YB5L-B 12V-5AH)	1				YUASA YUASA
5	90446-07805	TUBO RESEIRADERO HOSE	1				
6	21C-H2115-10	CABLE CONDUCTOR POSITIVO WIRE, PLUS LEAD	1				
7	21C-H2116-10	CABLE CONDUCTOR NEGATIVO WIRE, MINUS LEAD	1				
8	5YY-H2131-10	TIRANTE DE BATERIA BAND, BATTERY	1				
9	54B-H1960-00	RECTIFICADOR Y REGULADOR RECTIFIER & REGULATOR ASSY	1				
10	95607-06200	TUERCA DE AUTO-CIERRE NUT, SELF U-FLANGE	2				
11	95817-06025	TORNILLO BOLT, FLANGE	2				
12	90387-06048	ESPACIADOR COLLAR	2				
13	90202-05807	ARANDELA DE PLANA WASHER, PLATE	2				
14	21C-H2590-30	CONJUNTO DE CABLES WIRE HARNESS ASSY	1				
15	21C-H2599-00	CUBIERTA DE CONECTOR COVER, CONNECTER	1				
16	21C-H252U-00	CUBIERTA COVER	1				
17	90464-16061	BRIDA CLAMP	3				
18	90464-80802	BRIDA CLAMP	1				

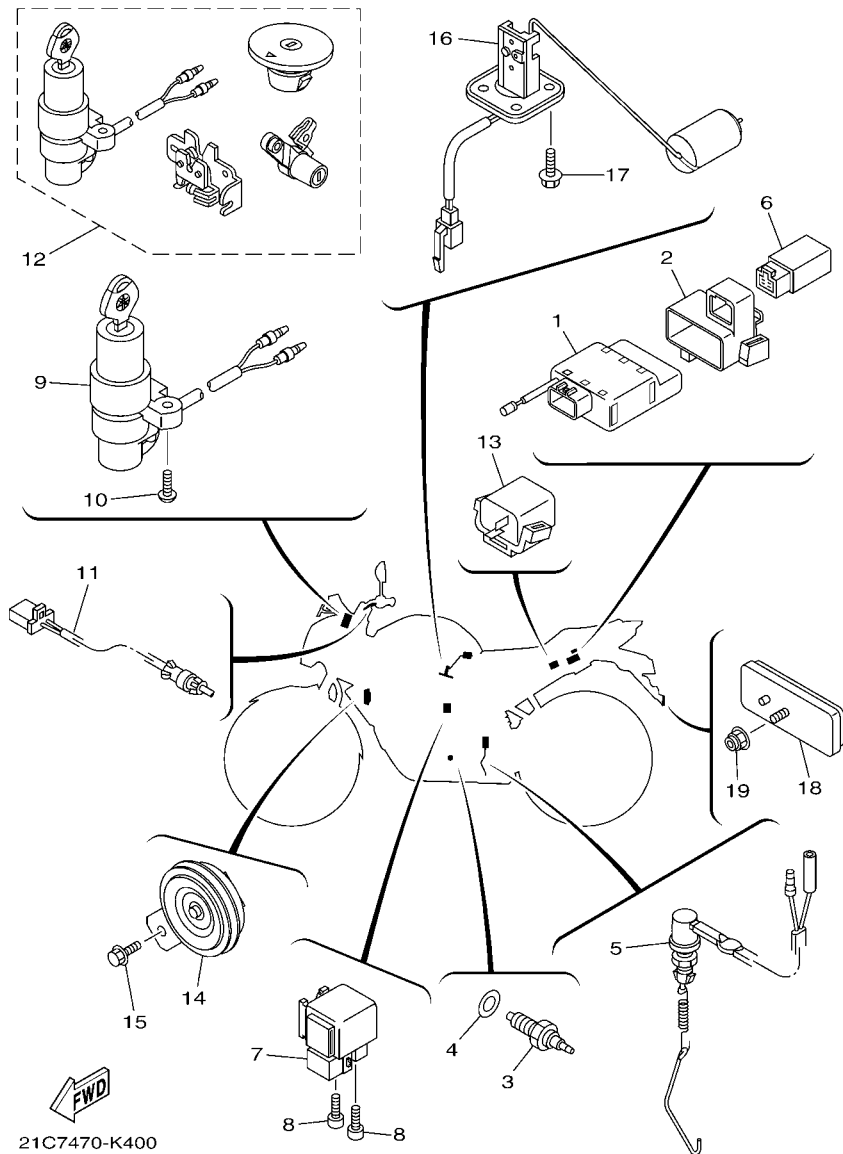


FIG. 41 EQUIPO ELECTRICO 2

ELECTRICAL 2

REF. N°	CODIGO N° PART NO.	DESCRIPCION DESCRIPTION	45D3			OBSERVACIONES REMARKS
1	21C-H5540-10	UNIDAD C.D.I. COMPLETA C.D.I. UNIT ASSY	1			
2	21C-H5546-10	BANDA BAND	1			
3	21C-H2540-00	INTERRUPTOR NEUTRAL COMPL NEUTRAL SWITCH ASSY	1			
4	90430-10148	JUNTA GASKET	1			
5	21C-H2530-00	INTERRUPTOR DE PARADA COMPLETO STOP SWITCH ASSY	1			
6	21C-H1951-01	RELE RELAY	1			
7	21C-H1940-10	CONJUNTO ARRANCADOR RELEVO STARTER RELAY ASSY	1			
8	91312-05008	TORNILLO BOLT	2			
9	21C-H2501-20	LLAVE DE IGNICION COMPLT MAIN SWITCH STEERING LOCK	1			
10	90149-06002	TORNILLO DE REGLAJE SCREW	2			
11	21C-H2917-00	INTERRUPTOR SWITCH	1			
12	21C-XH250-20	LLAVE DE IGNICION COMPLT MAIN SW. STRG. LOCK SUB ASSY	1			AP AP
13	21C-H3350-00	RELE DE DESTELLADOR COMPL. FLASHER RELAY ASSY	1			
14	21C-H3371-00	BOCINA HORN	1			
15	95827-06012	TORNILLO BOLT, FLANGE	1			
16	21C-H5701-02	MEDIDOR DE COMBUSTIBLE COMPL. SENDER ASSY	1			
17	90119-05071	TORNILLO CON ARANDELA BOLT, WITH WASHER	4			
18	5US-H5110-00	REFLECTOR COMPLETO REFLECTOR ASSY	1			
19	95707-05500	TUERCA DE BRIDA NUT, FLANGE	1			

INDICE NUMERICO  
NUMERICAL INDEX

CODIGO Nº PART NO.	REF. Nº	CODIGO Nº PART NO.	REF. Nº	CODIGO Nº PART NO.	REF. Nº	CODIGO Nº PART NO.	REF. Nº	CODIGO Nº PART NO.	REF. Nº	CODIGO Nº PART NO.	REF. Nº
21C-12117-00	3 - 7	54B-E1165-00	1 - 6	21C-E3449-00	5 - 10	54B-E5665-00	12 - 12	45D-F1110-20	17 - 1	45D-F174G-00	19 - 29
22F-12118-01	3 - 6	21C-E1166-10	6 - 24	21C-E3536-01	6 - 2	21C-E5671-00	12 - 6	45D-F113B-00	17 - 14	45D-F174G-10	19 - 29
21C-12159-00	3 - 9	45P-E1169-00	1 - 7	21C-E3542-00	6 - 8	21C-E5674-00	12 - 13	21C-F117K-00	25 - 9	45D-F174G-20	19 - 29
21C-14103-00	7 - 6	54B-E1181-00	1 - 19	21C-E3586-01	6 - 1	21C-E5767-00	12 - 7	45D-F1316-00	17 - 2	45D-F174G-30	19 - 29
21C-14105-00	7 - 4	54B-E1186-00	1 - 13	21C-E3595-00	6 - 7	54B-E6111-00	13 - 1	45D-F1317-00	17 - 5	5DG-F1778-00	19 - 10
21C-1410A-00	7 - 3	1ES-E1190-00	1 - 5	21C-E4411-00	6 - 10	21C-E6135-10	13 - 19	45D-F137U-10-33	24 - 12	21C-F177G-10	18 - 12
21C-1410E-00	7 - 30	21C-E1193-00	1 - 11	21C-E4412-00	6 - 11	54B-E6144-00	13 - 17	45D-F137U-10-P0	24 - 12	45D-F2110-00	20 - 1
22F-14139-00	7 - 23	54B-E1310-00	1 - 22	21C-E443E-00	6 - 16	54B-E6150-00	13 - 6	45D-F137U-10-P1	24 - 12	20P-F2129-00	20 - 4
1NT-14142-17	7 - 9	21C-E1351-00	1 - 23	21C-E4450-00	6 - 12	21C-E6154-00	13 - 7	45D-F137U-10-P2	24 - 12	21C-F2141-00	20 - 3
21C-14147-00	7 - 15	21C-E1400-09	2 - 1	21C-E4452-00	6 - 14	21C-E6193-00	13 - 3	45D-F137V-10-33	24 - 13	21C-F2151-00	20 - 9
3G2-1414A-72	7 - 7	21C-E1422-00	2 - 5	21C-E4453-00	6 - 13	54B-E6321-00	13 - 9	21C-F144G-00	24 - 13	21C-F2174-00	28 - 38
21C-1414M-41	7 - 8	54B-E1454-00	2 - 14	21C-E4485-00	6 - 19	21C-E6324-00	13 - 11	45D-F137V-10-P1	24 - 13	21C-F2184-00	20 - 2
5YY-14150-00	7 - 2	54B-E1476-00	2 - 19	21C-E449E-00	6 - 36	21C-E6331-00	13 - 10	45D-F137V-10-P2	24 - 13	21C-F2210-00	20 - 17
353-14186-00	7 - 20	21C-E1496-20	2 - 16	21C-E4613-00	8 - 11	21C-E6333-00	13 - 13	21C-F144G-00	31 - 25	21C-F3100-01	22 - 1
5LW-14191-00	7 - 27	21C-E1531-00	2 - 15	21C-E4703-10	8 - 1	21C-E6337-00	13 - 14	45D-F1511-10-0X	18 - 1	21C-F3102-01	22 - 2
21C-14216-00	7 - 29	54B-E1536-00	2 - 12	21C-E4718-00	8 - 2	3C1-E6344-00	13 - 18	45D-F1511-10-1X	18 - 1	21C-F3103-01	22 - 19
4KM-14216-00	7 - 26	21C-E1603-00	2 - 11	20P-E4747-00	8 - 10	54B-E6351-00	13 - 12	45D-F1511-10-2X	18 - 1	21C-F3110-00	22 - 18
21C-14275-00	7 - 12	21C-E1605-00	2 - 11		17 - 11	21C-E6356-01	13 - 16	45D-F1511-10-3X	18 - 1		22 - 35
21C-14340-00	7 - 11	21C-E1607-00	2 - 11	21C-E4775-00	8 - 9	54B-E6357-00	13 - 24	5C9-F1568-S0	23 - 38	21C-F3111-00	22 - 5
21C-14545-00	7 - 14	21C-E1631-00	2 - 8	21C-E4799-01	8 - 3	21C-E6358-00	13 - 15	21C-F1611-00	18 - 7		22 - 22
583-14561-00	7 - 19	21C-E1633-00	2 - 9	45P-E4803-10	6 - 34	21C-E6371-00	13 - 8	21C-F1638-01	17 - 13	21C-F3114-00	22 - 4
5YP-14561-00	7 - 25	21C-E1636-09	2 - 8	21C-E4815-00	6 - 28	21C-E6380-01	13 - 22	21C-F1650-00	20 - 13		22 - 21
45D-14901-00	7 - 1	21C-E1638-09	2 - 8	21C-E4872-00	6 - 27	21C-E7121-00	14 - 3	21C-F1651-00	18 - 8	21C-F3118-00	22 - 6
45D-1490J-00	7 - 5	21C-E1651-00	2 - 4	21C-E4877-00	6 - 18	21C-E7131-20	14 - 4	45D-F1668-00	20 - 16		22 - 23
5GH-14918-10	7 - 13	21C-E1681-01	2 - 2	21C-E4881-00	6 - 30	21C-E7141-40	14 - 5	21C-F1669-00	18 - 16	21C-F3121-20	37 - 10
21C-14958-00	7 - 10	54B-E2111-00	3 - 1	21C-E4882-00	6 - 31	21C-E7151-40	14 - 7	21C-F16A2-00	18 - 17	21C-F3122-00-P0	37 - 12
45D-1496A-00	7 - 18	21C-E2113-00	3 - 5	54B-E5111-00	9 - 1	21C-E7211-20	14 - 17	45D-F1711-10-P0	19 - 1	21C-F3126-01	22 - 3
5HK-14985-00	7 - 17	21C-E2119-00	3 - 3	21C-E5113-00	10 - 12	21C-E7221-20	14 - 18	21C-F1717-00	18 - 13	21C-F3132-00-P0	37 - 13
21C-14987-00	7 - 22	54B-E2121-00	3 - 2	54B-E5121-00	9 - 2	21C-E7231-30	14 - 21		19 - 9	21C-F3136-01	22 - 20
5LW-14994-00	7 - 28	21C-E2126-00	3 - 4	21C-E5155-00	9 - 3	21C-E7241-40	14 - 19	45D-F171A-00-33	23 - 13	21C-F3141-00	22 - 8
21C-16345-10	13 - 23	21C-E2151-00	3 - 8	54B-E5362-00	10 - 22	21C-E7251-40	14 - 22	45D-F171E-01-33	19 - 15		22 - 25
4FM-23125-40	22 - 16	21C-E2156-00	3 - 11	21C-E5411-10	10 - 3	21C-E7258-00	14 - 16	45D-F1721-10-P0	19 - 5	21C-F3146-00	22 - 15
	22 - 33	21C-E2170-00	4 - 1	21C-E5418-01	10 - 13	54B-E7258-00	13 - 2	45D-F172A-10-P0	19 - 2		22 - 32
4EB-23144-00	22 - 12	21C-E2210-00	4 - 13	21C-E5421-00	10 - 18	21C-E7402-40	14 - 20	45D-F172F-10-P0	19 - 6	21C-F3149-00	22 - 7
	22 - 29	5MX-E2213-01	4 - 14	21C-E542A-00	10 - 17	21C-E7411-40	14 - 6	45D-F1731-00-33	19 - 11		22 - 24
4EB-23145-01	22 - 14	21C-E2231-00	4 - 9	21C-E5441-00	10 - 1	4LS-E7456-00	14 - 27	45D-F1732-00	19 - 23	21C-F3156-00	22 - 13
	22 - 31	21C-E2241-00	4 - 10	45P-E5451-00	10 - 4	21C-E7471-00	14 - 10	45D-F1735-00	19 - 24		22 - 30
3YF-23418-00	21 - 8	54B-E2280-00	4 - 5	45P-E5461-00	10 - 19	21C-E8101-01	16 - 4	45D-F173E-00	19 - 27	21C-F3158-00	22 - 10
5US-25852-00	30 - 11	21C-E2288-00	4 - 6	21C-E5514-10	11 - 1	45D-E8110-00	16 - 9	45D-F173E-10	19 - 27		22 - 27
5US-25854-00	30 - 10	45P-E2435-00	1 - 14	21C-E5521-00	11 - 2	5VA-E8113-00	16 - 10	45D-F173E-20	19 - 27	21C-F3170-00	22 - 17
21C-27261-01	31 - 9	21C-E2437-00	4 - 17	45P-E5524-00	11 - 5	21C-E8140-00	16 - 1	45D-F173E-30	19 - 27		22 - 34
	31 - 29	21C-E2661-10	1 - 24	54B-E5580-00	11 - 8	21C-E8337-00	16 - 3	45D-F173F-00	19 - 28	21C-F3173-00	22 - 11
21C-85885-00	7 - 24	54B-E3300-00	5 - 1	4LS-E5598-00	4 - 11	21C-E8511-00	15 - 2	45D-F173F-10	19 - 28		22 - 28
54B-E1111-00	1 - 1	21C-E3327-00	5 - 11	21C-E5620-00	12 - 18	21C-E8512-00	15 - 3	45D-F173F-20	19 - 28	45D-F3174-00	21 - 16
21C-E1111F-00	4 - 4	21C-E3362-00	2 - 20	21C-E5641-10	12 - 2	21C-E8513-00	15 - 4	45D-F173F-30	19 - 28	21C-F317J-00	21 - 17
21C-E1161-00	1 - 27	4LS-E3411-00	5 - 5	45P-E5651-00	12 - 15	21C-E8531-00	15 - 5	45D-F173M-00	19 - 25	21C-F3181-00	22 - 9
21C-E1161-10	1 - 28	21C-E3440-00	5 - 6	54B-E5661-00	12 - 1	21C-E8535-00	15 - 6	45D-F173N-00	19 - 26		22 - 26
21C-E1161-20	1 - 29	21C-E3447-00	5 - 7	54B-E5664-10	12 - 11	21C-E8540-30	15 - 1	45D-F1741-00-33	19 - 12	21C-F3317-00	30 - 4



INDICE NUMERICO  
NUMERICAL INDEX

CODIGO Nº PART NO.	REF. Nº	CODIGO Nº PART NO.	REF. Nº	CODIGO Nº PART NO.	REF. Nº	CODIGO Nº PART NO.	REF. Nº	CODIGO Nº PART NO.	REF. Nº	CODIGO Nº PART NO.	REF. Nº
21C-F3340-00	22 - 36	21C-F472T-10	25 - 10	21C-F6311-10	29 - 2	20P-H213A-00	35 - 22	1ES-H4300-00	37 - 1	90111-08847	27 - 2
21C-F3346-00	22 - 39	1EP-F4730-01	25 - 1	21C-F6331-01	29 - 7		35 - 30	21C-H4312-00	37 - 5	90116-08552	28 - 20
5KA-F3411-00	22 - 38	45D-F4741-00	25 - 2	21C-F6335-00	29 - 3	45D-H2310-00	40 - 1	21C-H4314-00	37 - 2	90119-05071	41 - 17
5KA-F3412-00	21 - 1	4LS-F4741-00	18 - 14	5TS-F6372-00	29 - 4	20P-H2370-01	40 - 3	21C-H4347-00	37 - 3	90119-06044	19 - 18
5KA-F3413-00	21 - 2	45D-F4763-00	25 - 3	1EP-F7111-00	32 - 1	21C-H2501-20	41 - 9	21C-H4502-00	37 - 4	90119-06117	18 - 15
5KA-F3414-00	21 - 3	21C-F476U-00	24 - 2	21C-F7114-00	32 - 4	21C-H252U-00	40 - 16	21C-H4527-10	37 - 14	90119-06194	37 - 9
5YY-F3416-00	21 - 6	21C-F476V-00	24 - 4	45D-F7211-00	31 - 27	21C-H2530-00	41 - 5	21C-H4710-00	38 - 1	90123-08046	29 - 5
4LS-F341E-00	21 - 5	45D-F4773-00	25 - 12	21C-F721A-00	31 - 37	21C-H2540-00	41 - 3	21C-H4714-00	38 - 2	90149-06002	41 - 10
4LS-F341E-10	21 - 4	21C-F4780-01	25 - 5	21C-F7231-00	32 - 7	21C-H2590-30	40 - 14	21C-H4721-00	38 - 3	90149-06011	23 - 28
21C-F3435-00	21 - 10	21C-F478E-01	25 - 7	45D-F7311-00	32 - 15	21C-H2599-00	40 - 15	21C-H4723-00	38 - 4	90154-06061	18 - 6
21C-F3441-00	21 - 14	21C-F479T-00	25 - 14	21C-F7321-01	32 - 22	5YY-H2911-00	39 - 5	5US-H5110-00	41 - 18	90159-05065	23 - 18
5YY-F3462-00	22 - 37	21C-F479U-00	25 - 15	21C-F7413-00	31 - 6	21C-H2917-00	41 - 11	21C-H5540-10	41 - 1		24 - 10
45D-F4110-10	23 - 1	21C-F479V-00	25 - 16		31 - 22	21C-H3310-00	35 - 1	21C-H5546-10	41 - 2	90159-06033	25 - 11
45D-F411G-00	23 - 32	21C-F510C-10	26 - 2	21C-F7414-00	31 - 11	21C-H3311-00	35 - 2	21C-H5701-02	41 - 16	90160-05006	36 - 5
45D-F411J-00	23 - 33	21C-F5168-10-33	26 - 1		31 - 31		35 - 10	5US-W0016-00	27 - 10	90170-06128	3 - 10
21C-F4124-10	23 - 35	21C-F5181-00	26 - 8	21C-F7426-00	31 - 19		35 - 18	5US-W0041-00	30 - 9	90170-10405	2 - 26
45D-F4129-00-33	24 - 1	21C-F5183-01	26 - 7	20P-F7431-00	32 - 24		35 - 26	5US-W0045-00	27 - 7	90176-22081	21 - 13
45D-F4129-00-P0	24 - 1	21C-F530S-10	28 - 2	35B-F7437-00	32 - 30	20P-H3318-00	35 - 19	5US-W0047-00	27 - 4	90179-05523	23 - 19
45D-F4129-00-P1	24 - 1	5US-F5321-10	28 - 6	20P-F7441-00	32 - 25		35 - 27	5US-W0048-00	27 - 6		24 - 11
45D-F4129-00-P2	24 - 1	21C-F5338-10-33	28 - 1	21C-F7445-01	31 - 12	20P-H3318-10	35 - 3	5US-W0053-00	27 - 12	90179-06018	32 - 14
45D-F4139-00-33	24 - 3	36L-F533A-00	28 - 14	21C-F7446-01	31 - 32		35 - 11	5US-W0068-00	27 - 11	90179-08148	29 - 6
45D-F4139-00-P0	24 - 3	5YY-F5351-00	28 - 10	35B-F7451-00	31 - 1	5YY-H3318-10	35 - 33	21C-WF461-10	23 - 20	90179-08674	17 - 8
45D-F4139-00-P1	24 - 3	21C-F5355-01	28 - 11	21C-F7452-00-P0	31 - 2	21C-H331E-00	35 - 4	21C-WF479-00	25 - 8	90179-10658	17 - 4
45D-F4139-00-P2	24 - 3	21C-F5364-00	28 - 5	35B-F7461-00	31 - 17	21C-H3320-00	35 - 9	5YY-WF533-00	28 - 7	90179-12659	12 - 19
22P-F413B-00	24 - 20	20P-F5366-00-33	28 - 15	21C-F7462-00-P0	31 - 18	21C-H332E-00	35 - 12	21C-XH250-20	41 - 12	90179-12802	13 - 5
21C-F4141-00	23 - 14	45D-F5371-00	28 - 24	21C-F8100-20	17 - 15	21C-H3330-00	35 - 17	90101-06046	28 - 12	90179-14001	13 - 20
21C-F414A-00	23 - 15	20P-F5377-00	28 - 17	22P-F836B-00	19 - 21	20P-H3333-00	35 - 7	90101-10006	32 - 18	90179-25615	21 - 7
21C-F414H-10	24 - 5	21C-F5377-01	28 - 32	54B-H1410-00	33 - 2		35 - 15	90105-06859	30 - 14	90183-05042	18 - 11
21C-F4181-00	23 - 2	21C-F5381-00	28 - 31	21C-H1450-10	33 - 1		35 - 23	90105-08196	4 - 7		19 - 3
21C-F4182-00	23 - 3	21C-F5383-10	28 - 33	21C-H1800-10	34 - 1		35 - 31	90105-08197	1 - 17		19 - 7
21C-F4183-00	23 - 4	21C-F5388-11	28 - 37	5TP-H1801-00	34 - 2	21C-H3340-00	35 - 25	90105-10009	32 - 6		19 - 13
21C-F4188-10	23 - 12	45D-F5440-00	28 - 19	5D9-H1828-00	34 - 5	21C-H334E-00	35 - 28	90105-10079	17 - 10		24 - 15
45D-F4191-00	23 - 8	5US-F5744-00	27 - 8	21C-H183G-00	34 - 3	21C-H3350-00	41 - 13	90105-10319	27 - 13	90183-05061	24 - 9
45D-F4216-00	24 - 18	5YY-F580U-20	27 - 3	5D9-H1861-00	34 - 4	21C-H3371-00	41 - 14	90105-12030	20 - 20	90183-05076	24 - 17
45D-F4245-00	24 - 21	5US-F5827-00	27 - 9	21C-H1940-10	41 - 7	45S-H3500-20	36 - 3	90105-12660	20 - 19	90183-06023	6 - 21
45D-F4245-10	24 - 21	21C-F582U-00	27 - 1	21C-H1951-01	41 - 6	21C-H355M-00	35 - 20	90109-06259	16 - 2	90183-061A4	37 - 16
45D-F4245-20	24 - 21	21C-F583T-00	30 - 8	54B-H1960-00	40 - 9	20P-H3618-00	35 - 5	90109-06859	30 - 17	90185-06802	30 - 18
45D-F4245-30	24 - 21	5YY-F5867-00	30 - 13	3AY-H2110-00	40 - 4		35 - 13	90109-08063	28 - 25	90185-10091	32 - 21
21C-F4311-00	23 - 30	21C-F5872-00	30 - 5	21C-H2115-10	40 - 6		35 - 21	90109-08202	31 - 8	90201-05015	1 - 25
21C-F4318-00	23 - 16	21C-F5875-00	30 - 1	21C-H2116-10	40 - 7		35 - 29		31 - 24	90201-05036	38 - 7
21C-F4500-10	23 - 21	21C-F5876-00	30 - 3	20P-H2131-00	25 - 4	21C-H3756-01	36 - 1	90109-08368	28 - 28	90201-06037	4 - 16
54B-F4512-10	23 - 22	5US-F5977-00	27 - 5	5YY-H2131-10	40 - 8	21C-H3912-00	39 - 6	90110-06304	1 - 21	90201-06055	19 - 20
54B-F4514-10	23 - 23	45D-F6111-00	29 - 1	20P-H2133-00	35 - 8	5YY-H3922-01	30 - 16	90110-06846	1 - 26	90201-060A3	20 - 11
54B-F4521-10	23 - 24	21C-F620B-20	29 - 10		35 - 16	36L-H3936-00	39 - 11	90111-05003	24 - 7		23 - 9
54B-F4535-10	23 - 27	45D-F6240-00	29 - 9		35 - 24	36L-H3945-10	39 - 7	90111-05808	5 - 2	90201-060H9	16 - 13
54B-F4564-10	23 - 25	45D-F6241-00	29 - 8		35 - 32	21C-H3963-01	39 - 4	90111-06087	8 - 6	90201-06726	18 - 5
54B-F4598-10	23 - 26	21C-F6280-00	39 - 1	20P-H213A-00	35 - 6	21C-H3972-01	39 - 3	90111-06121	37 - 15	90201-08079	31 - 16
21C-F4614-00-P0	23 - 17	21C-F6290-00	39 - 2		35 - 14	21C-H3980-00	30 - 15	90111-06807	8 - 7		31 - 36

INDICE NUMERICO  
NUMERICAL INDEX

CODIGO Nº PART NO.	REF. Nº	CODIGO Nº PART NO.	REF. Nº	CODIGO Nº PART NO.	REF. Nº	CODIGO Nº PART NO.	REF. Nº	CODIGO Nº PART NO.	REF. Nº	CODIGO Nº PART NO.	REF. Nº
90201-08612	8 - 13	90387-06737	6 - 22	90506-26807	31 - 28	93210-19809	10 - 23	95027-06045	9 - 7	95827-06012	24 - 19
90201-087F0	8 - 17	90387-068C5	18 - 2	90506-35816	32 - 3	93210-29807	34 - 7	95027-06050	10 - 7		30 - 2
90201-08834	39 - 10	90387-068C9	10 - 15	90508-183B9	31 - 3	93210-30611	6 - 3	95027-06055	9 - 6		41 - 15
90201-10021	31 - 10	90387-068D4	37 - 7	90508-32805	16 - 5	93210-32814	10 - 11	95027-06065	5 - 9	95827-06016	6 - 23
	31 - 30	90387-068S1	20 - 14	91312-05008	41 - 8	93306-002X2	4 - 3	95027-06070	9 - 8	95827-06030	23 - 11
90201-101J1	32 - 20	90387-08822	17 - 12	91312-06016	33 - 4	93306-054Y5	28 - 16	95027-08040	21 - 11	95827-08016	25 - 13
90201-105E8	11 - 3	90387-10003	32 - 19	91312-06020	34 - 6	93306-054Y6	14 - 8	95027-10025	32 - 23	97012-06020	16 - 14
90201-10815	30 - 7	90387-107H6	23 - 7	91312-06030	33 - 3	93306-054YE	14 - 8	95307-06600	28 - 13	97017-06014	18 - 9
90201-12019	13 - 4	90387-10822	32 - 2	91317-05010	1 - 8	93306-201Y4	14 - 9	95307-08600	28 - 29	97027-06020	18 - 4
90201-12030	20 - 8	90387-12845	20 - 18	91317-05016	3 - 12	93306-203XR	14 - 23		28 - 40	97027-06025	20 - 12
90201-122H1	20 - 22	90387-155J0	2 - 21	91317-06014	10 - 2	93306-252XG	26 - 4	95307-08700	28 - 26	9750M-06425	39 - 9
	33 - 6	90387-20813	2 - 13	91317-06016	6 - 29		28 - 3	95602-08200	28 - 21	97602-05320	6 - 15
90201-142M6	26 - 10	90401-10818	30 - 6		12 - 14	93306-252YG	2 - 22	95602-14200	28 - 34	97702-40030	38 - 5
90201-15022	2 - 17	90430-06014	1 - 3	91317-06018	4 - 15	93306-253Y6	2 - 23	95607-06200	40 - 10	97707-40014	37 - 11
90201-15026	28 - 35		1 - 16	91317-06020	11 - 9	93306-272X1	14 - 24	95607-10200	32 - 5	97707-50012	19 - 4
90201-162H4	12 - 10	90430-10148	41 - 4	91317-06025	1 - 12	93306-272X4	14 - 24	95607-14200	26 - 9		19 - 8
90201-167P7	12 - 8	90430-12227	5 - 4		1 - 15	93306-305YR	2 - 6	95614-12100	20 - 7		19 - 14
90201-177G4	12 - 16	90445-13806	32 - 17		6 - 6	93310-325X3	11 - 6	95617-08620	1 - 4		19 - 16
	14 - 15	90446-07805	40 - 5	91401-20012	16 - 11	93310-628X0	2 - 3	95617-12100	20 - 21		24 - 14
90201-20685	12 - 4	90450-44803	6 - 4		28 - 27	93315-112Y9	13 - 26	95707-05500	41 - 19	97707-50025	38 - 6
90201-220T0	21 - 12	90450-50802	6 - 20		32 - 8	93317-318Y5	20 - 6	95707-06300	39 - 8	98502-06016	19 - 19
90201-22793	14 - 12	90464-11014	6 - 37	91401-25015	31 - 5	93410-20038	12 - 5	95707-08500	8 - 12	98507-04008	7 - 21
90201-25290	11 - 7	90464-14803	36 - 2		31 - 21		14 - 2	95707-12500	33 - 5	98507-05010	24 - 16
90202-05180	24 - 8	90464-16016	6 - 38		32 - 27	93410-22039	14 - 13	95802-06020	4 - 12	98507-05012	7 - 16
90202-05807	8 - 8	90464-16061	40 - 17	91701-08035	32 - 26	93450-16812	2 - 10	95807-06010	31 - 26	98507-05014	31 - 7
	23 - 29	90464-80802	23 - 5	91701-08040	31 - 4	93501-04805	32 - 29	95807-06014	20 - 15		31 - 23
	40 - 13		40 - 18		31 - 20	93505-16844	13 - 25	95807-06020	10 - 14	98507-06012	19 - 17
90202-26142	21 - 9	90467-08808	6 - 9	91810-14804	1 - 20	93605-06800	4 - 2	95807-06025	37 - 8	98517-06012	14 - 11
90208-20003	13 - 21	90467-100A3	23 - 31	91830-21014	9 - 4	93608-43238	16 - 7	95807-08025	8 - 14	98706-04012	30 - 12
90208-20005	12 - 3	90467-12800	6 - 17		10 - 5	93612-16254	1 - 10	95807-08035	8 - 15	99001-10600	16 - 6
90209-17285	14 - 1	90467-13816	6 - 25		10 - 20	93822-14800	14 - 26	95812-06014	31 - 13	99009-10400	11 - 4
90209-18208	14 - 14	90467-15012	6 - 32	92907-06200	16 - 12	93900-00824	26 - 6		31 - 33	99009-16400	12 - 9
90214-10006	2 - 18	90467-16805	6 - 26		32 - 9		28 - 23		31 - 38	99009-17400	12 - 17
90215-10284	2 - 25		6 - 33		32 - 11	94110-17804	26 - 5	95817-06025	40 - 11	99009-20500	13 - 28
90240-06804	32 - 10	90480-01559	19 - 22	92907-06600	6 - 5	94114-17800	28 - 22	95817-08016	17 - 7		
90249-12008	32 - 13	90480-08801	18 - 3	92907-08200	28 - 30	94568-B5128	28 - 36	95817-08025	31 - 15		
90280-03017	2 - 7	90480-12581	8 - 4	92907-08600	28 - 39	94591-69096	4 - 8		31 - 35		
90282-05031	2 - 24	90480-12812	10 - 16	93101-10838	10 - 24	94703-00885	1 - 18	95817-08035	17 - 6		
90338-05801	9 - 5	90480-13398	24 - 6	93102-12875	16 - 8	95022-06012	1 - 2		31 - 14		
90340-12097	5 - 3	90480-14101	37 - 6	93102-12877	13 - 27		5 - 12		31 - 34		
90340-14824	10 - 8	90480-14818	36 - 4	93102-22818	14 - 25	95024-08035	21 - 15	95817-08040	8 - 16		
90340-32823	10 - 10	90480-14819	38 - 8	93106-22808	26 - 3	95027-06010	14 - 28	95817-10080	17 - 3		
90387-06023	8 - 5	90501-06800	15 - 7		28 - 4		25 - 6	95817-10130	17 - 9		
90387-06048	18 - 10	90501-10245	32 - 12	93106-26801	28 - 18	95027-06016	4 - 18	95827-06012	6 - 35		
	23 - 36	90501-12743	32 - 28	93109-18803	20 - 5	95027-06020	5 - 8		21 - 18		
	40 - 12	90506-12001	28 - 8	93109-20821	12 - 20		40 - 2		23 - 10		
90387-06554	23 - 6	90506-15001	28 - 9	93210-12800	1 - 9	95027-06040	10 - 6		23 - 34		
90387-066J9	20 - 10	90506-23807	32 - 16	93210-14899	10 - 9		10 - 21		23 - 37		