

**PARTS
CATALOGUE
CATALOGO
DE REPUESTOS**

DT125 (3TT7) DOMINICA,SOUTH AFRICA

DT125 (3TT8) DOMINICA

DT175 (3TS9) DOMINICA,SOUTH AFRICA

DT175 (3TSA) DOMINICA,MEXICO

DT125/DT175
PARTS CATALOGUE
©2002 by Yamaha Motor Co., Ltd.
1st Edition, Feb. 2002
All rights reserved.
Any reprinting or unauthorized use
without the written permission of
Yamaha Motor Co., Ltd.
is expressly prohibited.
Printed in Japan

DT125/DT175
CATALOGO DE REPUESTOS
©2002, Yamaha Motor Co., Ltd.
1ª edición, Feb. 2002
Reservados todos los derechos.
Se prohíbe expresamente toda reimpresión
o utilización no autorizada de este manual
sin el consentimiento por escrito de
Yamaha Motor Co., Ltd.
Impreso en Japón

FOREWORD

This Parts Catalogue is related to the parts for the model(s) in the below frame. When you are ordering replacement parts, please refer to this Parts Catalogue and quote both part numbers and part names correctly.

DT125(3TT7,3TT8),DT175(3TS9,3TSA)

1. Modifications or additions which have been made after issue of the Parts Catalogue will be announced in the Yamaha Parts News.
It is advisable that you make necessary corrections to the Parts Catalogue according to the Yamaha Parts News.

2. Abbreviations
The Following abbreviations are used in this Parts Catalogue.

“UR” Use specified parts number.

“UN” Use as many as needed.

“AP” Alternate Parts

“LM” Local Made (Parts need to be ordered locally)

“F#” Frame No. (Applicable machine No.)

3. Parts, which are to be supplied in an assembly, are listed with a dot(.) in front of the part name as shown below.

EXAMPLE

CARBURETOR ASSY

.JET, PILOT

.NOZZLE, MAIN

4. Number of component for assembly
The numeral appearing to the right of each component part indicates the quantity of parts for each assembly unit.

EXAMPLE

PART NO.	DESCRIPTION	Q'TY	REMARKS
2F5-83310-60	FRONT FLASHER LIGHT ASSY	2	
115-83311-60	.BULB (6V-18W)	1	
1M1-83309-60	.REFLECTOR	1	

5. Applicable colors of graphics are represented in the “REMARKS” as shown below.

PART NO.	DESCRIPTION	Q'TY	REMARKS
2N4-24110-00-X5	FUEL TANK COMP.	1	MXR
3J1-24240-10	.GRAPHIC, FUEL TANK	1	FOR MXR

6. Applicable Serial No.

Engine Serial No.

Frame Serial No.

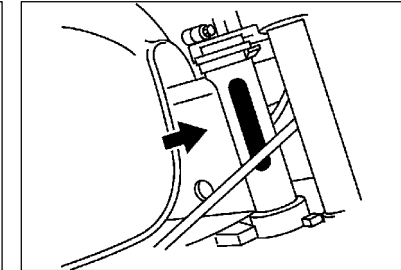
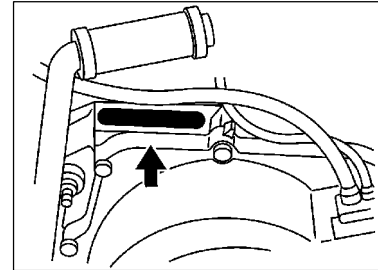

7. Note that the illustrations for reference in finding parts numbers, not to be used for assembling. When assembling, please use the applicable service manual.

8. The asterisk (*) before a reference number indicates modification items after the first edition.

PROLOGO

Este Catálogo de Repuestos corresponde a las piezas para el(los) modelo(s) del recuadro siguiente. Al formular el pedido de repuestos, se ruega citar este Catálogo de Repuestos y especificar correctamente los números de parte y los nombres de parte.

DT125(3TT7,3TT8),DT175(3TS9,3TSA)

1. Las modificaciones y agregados que se hayan realizado después de la edición de este Catálogo de Repuestos, serán anunciados en las Informaciones de Recambios Yamaha.
2. Abreviaciones
En este Catálogo de Repuestos se emplean las siguientes abreviaciones.
"UR" Usar el número de partes especificado
"UN" Usar la cantidad necesaria
"AP" Piezas sustitutivas
"LM" Fabricación local (Partes necesarias que se pedirán localmente)
"F#" No. de bastidor aplicable
3. Las piezas suministradas como conjunto se describen con un punto (.) que precede al nombre de la pieza como se indica a continuación.

EJEMPLO

CONJUNTO CARBURADOR

.INYECTOR, piloto

.BOQUILLA, principal

4. Cantidad de componentes de un conjunto
La numeración que aparece a la derecha de cada descripción, indica la cantidad de piezas por cada unidad de conjunto.

EJEMPLO

PIEZAS NO.	DESCRIPCION	CANT.	OBSERVACION
2F5-83310-60	ENSAMBLAJE DE LA LUZ	2	
115-83311-60	.BOMBILLA (6V-1 8W)	1	
1M1-83309-60	.REFLECTOR	1	

5. Los colores de los componentes se indican como sigue en la columna de "OBSERVACIONES".

EJEMPLO

PIEZAS NO.	DESCRIPCION	CANT.	OBSERVACION
2N4-24110-00-X5	COMP. DEL TANQUE	1	MXR
3J1-24240-10	.GRAFICO, DEL TANQUE	1	PARA MXR

6. Números de Serie

No. de Serie del motor.

No. de Serie del bastidor

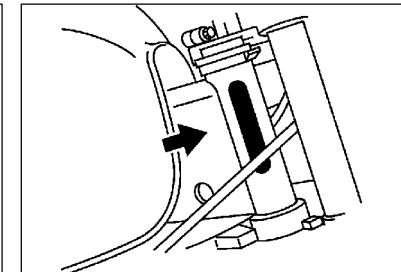
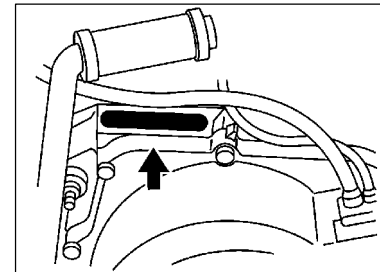

7. Debe tenerse en cuenta que las ilustraciones sirven como guía para la búsqueda de las referencias y no deben usarse para el montaje. Durante el montaje, se recomienda usar el manual de Taller correspondiente.
8. EL asterisco (*) antes del número de referencia indica los elementos modificados después de la primera edición.

MODEL LABEL

(1) A label called "Model Label" is affixed in the location as indicated in (3) below.
When using this parts catalogue, please be sure to cross-refer the "model code – production code No." in the catalogue to the "model code – production code No." indicated on the Model Label affixed onto the product concerned.

(2) "Model Label" Indication

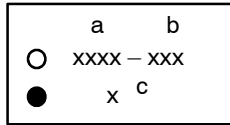

a: Model Type Code
b: Production Code No.
c: Colouring Type

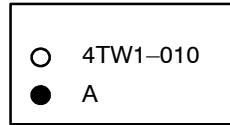

(3) Model Label Affixing Location

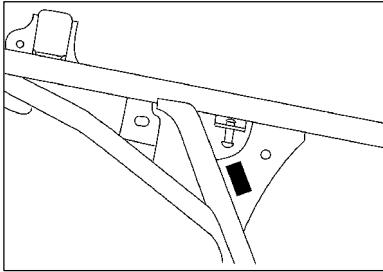

(4) Model Code – Production Code Number of Model Listed in This Parts Catalog

Model Code	Production Code No.	Country (destination)	Model Code	Production Code No.	Country (destination)
3TT7	010	DOMINICA			
	020	SOUTH AFRICA			
3TT8	010	DOMINICA			
3TS9	010	DOMINICA			
	020	SOUTH AFRICA			
3TSA	010	DOMINICA			
		MEXICO			

(5) Colouring Information

Model Code	Colouring type code	Colour code	Colour Name	Abbreviation
3TT7	A	0390	BLUISH WHITE COCKTAIL 1	BWC1
	B	0580	VIVID RED COCKTAIL 7	VRC7
3TT8	C	0521	CYAN METALLIC 3	CM3
3TS9				
3TSA	D	0564	DEEP PURPLISH BLUE METALLIC C	DPBMC

ROTULO DE MODELO

(1) El rótulo llamada “Rótulo de Modelo” está en la ubicación indicada abajo en el (3). Cuando se utilice este catálogo de partes, se ruega cotejar entre el “código de modelo–número de código de producción” del catálogo y el “código de modelo–número de código de producción” indicado en el Rótulo de Modelo fijado en el producto correspondiente.

(2) Indicación del “Rótulo de Modelo”

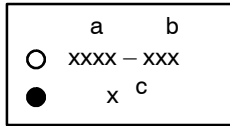

a: Código de tipo de Modelo

b: Número de código de Producción

c: Tipo de color

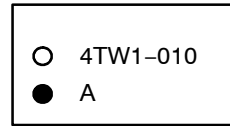

(3) Ubicación de fijación del Rótulo de Modelo

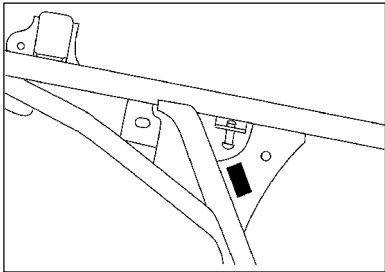

(4) Código de Modelo–Número de código de Producción del Modelo Listado en este Catálogo de Partes

Código de Modelo	Número de Código de Producción	Pais(destine)	Código de Modelo	Número de Código de Producción	Pais(destine)
3TT7	010	DOMINICA			
	020	SOUTH AFRICA			
3TT8	010	DOMINICA			
3TS9	010	DOMINICA			
	020	SOUTH AFRICA			
3TSA	010	DOMINICA			
		MEXICO			

(5) Información de Color

Código de Modelo	Código de tipo de color	Código de color	Nombre de color	Abreviatura
3TT7	A	0390	BLUISH WHITE COCKTAIL 1	BWC1
	B	0580	VIVID RED COCKTAIL 7	VRC7
3TT8	C	0521	CYAN METALLIC 3	CM3
3TS9	D	0564	DEEP PURPLISH BLUE MEYALLIC C	DPBMC
3TSA				

CONTENTS

ENGINE

CYLINDER	1
CRANKSHAFT. PISTON	2
OIL PUMP	4
INTAKE	6
CARBURETOR	8
EXHAUST	10
CRANKCASE	11
CRANKCASE COVER 1	12
STARTER	13
CLUTCH	14
TRANSMISSION	16
TACHOMETER GEAR	18
SHIFT CAM. FORK	19
SHIFT SHAFT	20

CHASSIS

FRAME	21
FENDER	22
SIDE COVER	23
OIL TANK	25
REAR ARM	26
REAR SUSPENSION	28
STEERING	29
STEERING 2	30
FRONT FORK	31
FRONT FORK 2	33
FUEL TANK	35
SEAT	37
FRONT WHEEL	38

FRONT WHEEL 2	40
FRONT BRAKE CALIPER	41
REAR WHEEL	42
STEERING HANDLE. CABLE	44
STEERING HANDLE. CABLE 2	46
STEERING.CABLE (DISK BRAKE)	48
FRONT MASTER CYLINDER	50
STAND. FOOTREST	51
COWLING 1	53
GENERATOR 1	54
GENERATOR 2	55
FLASHER LIGHT	56
FLASHER LIGHT 2	57
METER	58
HEADLIGHT	60
HEADLIGHT 2	61
TAILLIGHT	62
HANDLE SWITCH. LEVER	63
HANDLE SWITCH. LEVER 2	64
SWITCH.LEVER (DISK BRAKE)	65
ELECTRICAL 1	66
ELECTRICAL 2	67

INDEX

NUMERICAL INDEX	68
-----------------------	----

CONTENIDO

MOTOR

CILINDRO	1
CIGUENAL. PISTON	2
BOMBA DE ACEITE	4
ADMISION	6
CARBURADOR	8
DESCARGA	10
CARTER	11
CUBIERTA DE CARTER 1	12
ARRANQUE	13
EMBRAGUE	14
TRANSMISION	16
ENGR. DE TACOMETRO	18
LEVA DE CAMBIO. HORQ	19
EJE DE CAMBIO. PEDAL	20

SHASIS

CUADRO	21
GUARDABARRO	22
CUBIERTA LATERAL	23
DEPOSITO DE ACEITE	25
BRAZO TRASERO	26
SUSPENSION TRASERO	28
DIRECCION	29
DIRECCION 2	30
HORQUILLA DELANTERA	31
HORQUILLA DELANTERA 2	33
DEPOSITO DE COMBUSTIBLE	35
ASIENTO	37
RUEDA DELANTERA	38

RUEDA DELANTERA 2	40
CALIBRE FRENO DELANTERA	41
RUEDA TRASERA	42
MANUBRIO. CABLE	44
MANUBRIO. CABLE 2	46
MANUBRIO CABLE(DISCO DE FRENO)	48
CILINDRO MAESTRO DELANTERO	50
SOPORTE. APOYAPIE	51
BOVEDA 1	53
GENERADOR 1	54
GENERADOR 2	55
LUZ DE DESTELLADOR	56
LUZ DE DESTELLADOR 2	57
MEDIDOR	58
FARO DELANTERO	60
FARO DELANTERO 2	61
LUZ DE COLA	62
INTERRUPTOR DE MANIJA. PALANCA	63
INTERRUPTOR DE MANIJA. PALANCA 2	64
INTERRUPTOR DE MANIJA. PALANCA(DISCO)	65
EQUIPO ELECTRICO 1	66
EQUIPO ELECTRICO 2	67

INDICE

INDICE NUMERICO	68
-----------------------	----

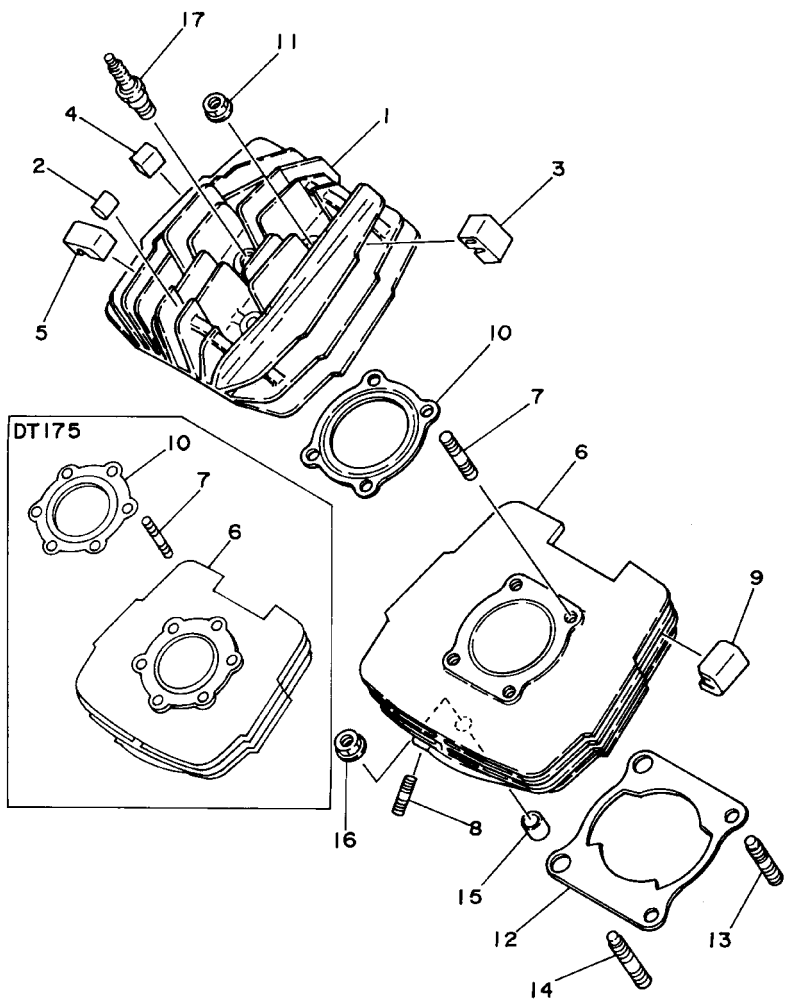

FWD
3TT4200-6010

FIG. 1 CYLINDER

CILINDRO

REF. NO.	PART NO. CODIGO NO.	DESCRIPTION DESCRIPTION	3TT7	3TT8	3TS9	3TSA	REMARKS OBSERVACION
1	18G-11111-00	HEAD, CYLINDER 1 CULATA CILINDRO 1	1	1			
	18L-11111-00	HEAD, CYLINDER 1 CULATA CILINDRO 1			1	1	
2	4F2-11162-00	ABSORBER 2 AMORTIGUADOR 2	4	4			
	363-11161-00	ABSORBER 1 AMORTIGUADOR 1			5	5	
3	18G-11161-00	ABSORBER 1 AMORTIGUADOR 1	1	1	1	1	
4	18G-11162-00	ABSORBER 2 AMORTIGUADOR 2	1	1	1	1	
5	18G-11128-00	ABSORBER 4 AMORTIGUADOR 4	2	2	2	2	
6	18G-11311-01	CYLINDER 1 CILINDRO 1	1	1			
	18L-11311-00	CYLINDER 1 CILINDRO 1			1	1	
7	90116-08394	BOLT, STUD ESPARRAGO	4	4	6	6	
8	90116-06016	BOLT, STUD ESPARRAGO	2	2	2	2	
9	18G-11127-00	ABSORBER 3 AMORTIGUADOR 3	4	4	4	4	
10	2A6-11181-00	GASKET, CYLINDER HEAD 1 JUNTA, DE CULATA 1	1	1			
	2A7-11181-10	GASKET, CYLINDER HEAD 1 JUNTA, DE CULATA 1			1	1	
11	90179-08299	NUT TUERCA	4	4	6	6	
12	18G-11351-02	GASKET, CYLINDER JUNTA, DE CILINDRO	1	1			
	3TN-11351-00	GASKET, CYLINDER JUNTA, DE CILINDRO			1	1	
13	90116-10278	BOLT, STUD ESPARRAGO	2	2	2	2	
14	90116-10279	BOLT, STUD ESPARRAGO	2	2	2	2	
15	99530-14016	PIN, DOWEL PASADOR, DE CLAVIJA	2	2	2	2	
16	90179-10279	NUT TUERCA	4	4	4	4	
17	94701-00045	PLUG, SPARK (NGK B8ES) BUJIA (NGK B8ES)	1	1	1	1	

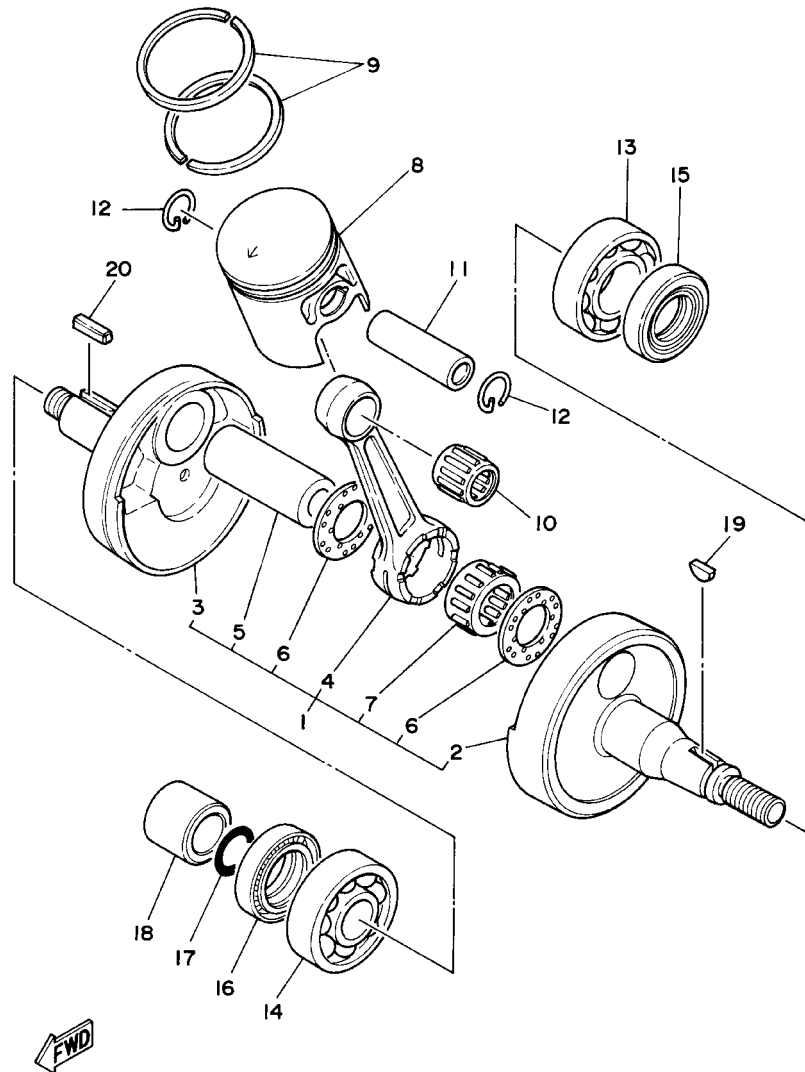

3TT1200-0020

FIG. 2 CRANKSHAFT. PISTON

CIGUENAL. PISTON

REF. NO.	PART NO. CODIGO NO.	DESCRIPTION DESCRIPTION	3TT7	3TT8	3TS9	3TSA	REMARKS OBSERVACION
1	18G-11400-00	CRANKSHAFT ASSY CIGUENAL COMPLETO	1	1	1	1	
2	1W1-11412-01	.CRANK 1 .MANIVELA 1	1	1	1	1	
3	1W1-11422-01	.CRANK 2 .MANIVELA 2	1	1	1	1	
4	4Y2-11651-00	.ROD, CONNECTING .BIELA	1	1	1	1	
5	3M5-11681-00	.PIN, CRANK 1 .PASADOR MANIVELA 1	1	1	1	1	
6	90209-22071	.WASHER .ARANDELA DE SEPARACION	2	2	2	2	
7	93310-42231	.BEARING .COJINETE DE RODILLOS	1	1	1	1	
8	18G-11631-01-96	PISTON (STD) PISTON (STD)	1	1			
	18L-11631-00-97	PISTON (STD) PISTON (STD)			1	1	
	18G-11635-01	PISTON (0.25MM O/S) PISTON (0.25MM O/S)	1	1			AP
	18L-11635-00	PISTON (0.25MM O/S) PISTON (0.25MM O/S)			1	1	AP
	18G-11636-01	PISTON (0.50MM O/S) PISTON (0.50MM O/S)	1	1			AP
	18L-11636-00	PISTON (0.50MM O/S) PISTON (0.50MM O/S)			1	1	AP
9	3TL-11603-00	PISTON RING SET (STD) JUEGO DE ANILLOS (STD)	1	1			
	3TK-11603-00	PISTON RING SET (STD) JUEGO DE ANILLOS (STD)			1	1	
	3TL-11604-00	PISTON RING SET (0.25MM O/S) JUEGO DE ANILLOS (0.25MM O/S)	1	1			AP
	3TK-11604-00	PISTON RING SET (0.25MM O/S) JUEGO DE ANILLOS (0.25MM O/S)			1	1	AP
	3TL-11605-00	PISTON RING SET (0.50MM O/S) JUEGO DE ANILLOS (0.50MM O/S)	1	1			AP
	3TK-11605-00	PISTON RING SET (0.50MM O/S) JUEGO DE ANILLOS (0.50MM O/S)			1	1	AP
10	93310-216A3	BEARING COJINETE DE RODILLOS	1	1			
	93310-216E1	BEARING COJINETE DE RODILLOS			1	1	
11	4Y2-11633-00	PIN, PISTON PASADOR, PISTON	1	1			
	251-11633-00	PIN, PISTON PASADOR, PISTON			1	1	
12	93450-17025	CIRCLIP SEGURO	2	2			
	93450-17044	CIRCLIP SEGURO			2	2	
13	93306-30421	BEARING (B6304C3) COJINETE (B6304C3)	1	1			
	93306-20529	BEARING (B6205C4) COJINETE (B6205C4)			1	1	

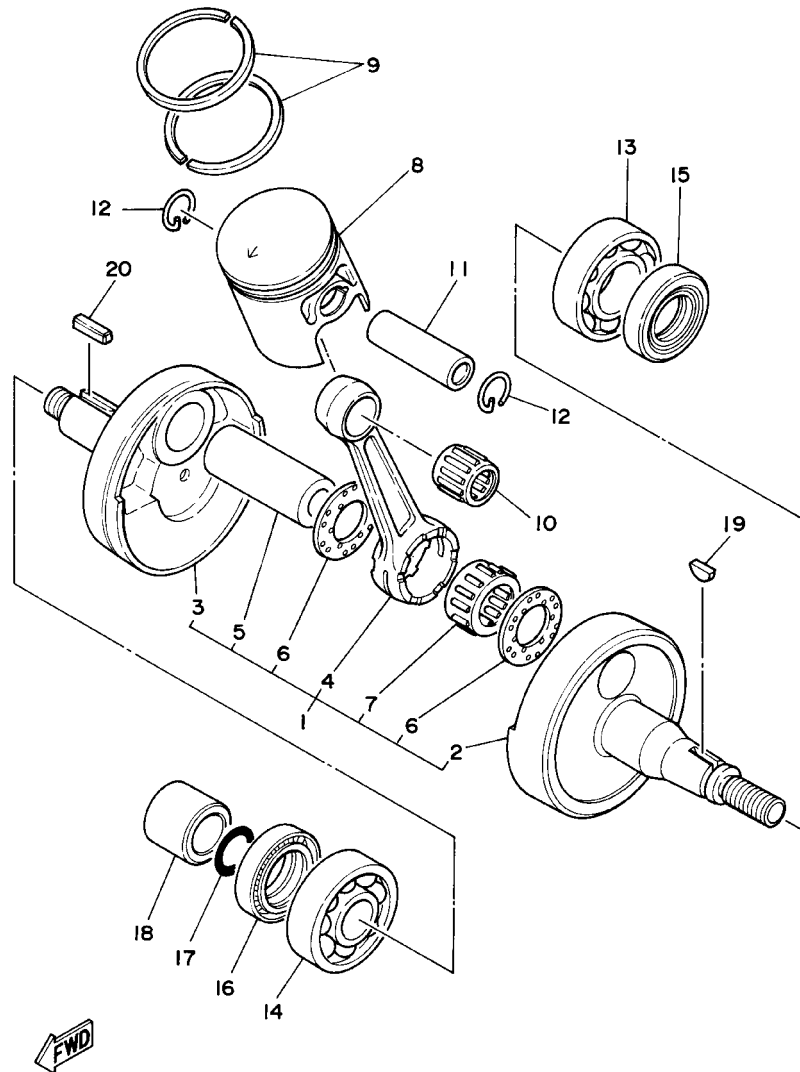

3TT1200-0020

FIG. 2 CRANKSHAFT. PISTON

CIGUENAL. PISTON

REF. NO.	PART NO. CODIGO NO.	DESCRIPTION DESCRIPTION	3TT7	3TT8	3TS9	3TSA	REMARKS OBSERVACION
14	93306-20529	BEARING (B6205C4) COJINETE (B6205C4)	1	1			
	93306-30421	BEARING (B6304C3) COJINETE (B6304C3)			1	1	
15	93102-25061	OIL SEAL RETEN DE ACEITE	1	1	1	1	
16	93103-28011	OIL SEAL RETEN DE ACEITE	1	1	1	1	
17	93210-18023	O-RING JUNTA TORICA	1	1	1	1	
18	90387-20488	COLLAR COLLAR	1	1	1	1	
19	90280-03017	KEY, WOODRUFF CUNA WOODRUFF	1	1	1	1	
20	90282-05005	KEY, STRAIGHT CHAVETA, RECTA	1	1	1	1	

FIG. 3 OIL PUMP

BOMBA DE ACEITE

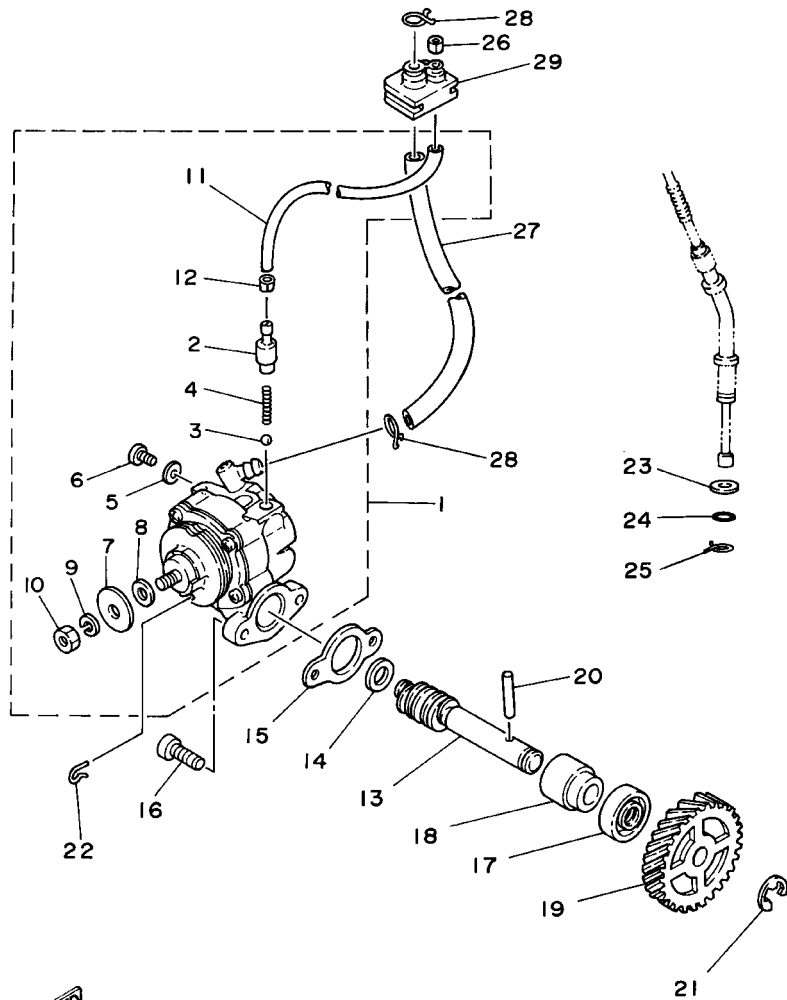

FWD
3TTI200-0030

REF. NO.	PART NO. CODIGO NO.	DESCRIPTION DESCRIPTION	3TT7	3TT8	3TS9	3TSA	REMARKS OBSERVACION
1	18G-13101-00	OIL PUMP ASSY	1	1			
	18L-13101-00	BOMBA DE ACEITE COMPLETA			1	1	
2	402-13552-00	.NOZZLE	1	1	1	1	
		.BOQUILLA					
3	93505-32002	.BALL	1	1	1	1	
		.ESFERA					
4	90501-02217	.SPRING, COMPRESSION	1	1	1	1	
		.RESORTE DE COMPRESION					
5	90430-04004	.GASKET	1	1	1	1	
		.JUNTA					
6	98901-04008	.SCREW, BIND	1	1	1	1	
		.TORNILLO					
7	137-13138-01	.PLATE, ADJUSTING	1	1	1	1	
		.PLACA DE AJUSTE					
8	137-13137-00-03	.SHIM (T=0.3)	1	1	1	1	UR
		.CUNA EMBOLO (T=0.3)					
	137-13137-00-05	.SHIM (T=0.5)	1	1	1	1	UR
		.CUNA EMBOLO (T=0.5)					
	137-13137-00-10	.SHIM (T=1.0)	1	1	1	1	UR
		.CUNA EMBOLO (T=1.0)					
9	92901-05100	.WASHER, SPRING	1	1	1	1	
		.ARANDELA PLANA					
10	95301-05600	.NUT	1	1	1	1	
		.TUERCA HEXAGONAL					
11	90445-05681	.HOSE (L210)	1	1	1	1	
		.TUBO (L210)					
12	90468-02033	.CLIP	1	1	1	1	
		.PRESILLA					
13	522-13175-01	.SHAFT, WORM	1	1			
		EJE, SINFIN					
	275-13175-01	.SHAFT, WORM			1	1	
		EJE, SINFIN					
14	90201-08624	.WASHER, PLATE	1	1	1	1	
		.ARANDELA PLANA					
15	126-13116-01	.GASKET, PUMP CASE	1	1	1	1	
		.JUNTA, CAJA DE BOMBA					
16	98507-05014	.SCREW, PAN HEAD	2	2	2	2	
		.TORNILLO DE CABEZA CON PLANA					
17	93101-10001	.OIL SEAL	1	1	1	1	
		.RETEN DE ACEITE					
18	137-13176-00	.METAL, WORM SHAFT OUTER	1	1	1	1	
		.CASQUILLO, EXT.DE EJE SINFIN					
19	2A6-13178-00	.GEAR, DRIVE (24T)	1	1	1	1	
		.ENGRANAJE TRACC.DE BOMBA (24T)					
20	93603-22028	.PIN, DOWEL	1	1	1	1	
		.PASADOR DE CLAVIJA					
21	99001-08600	.CIRCLIP	1	1	1	1	
		.PRESILLA REDONDA					
22	363-13133-01	.CLIP	1	1	1	1	
		.PRESILLA					
23	92906-08600	.WASHER, PLATE	1	1	1	1	
		.ARANDELA, PLANA					

FIG. 4 INTAKE

ADMISION

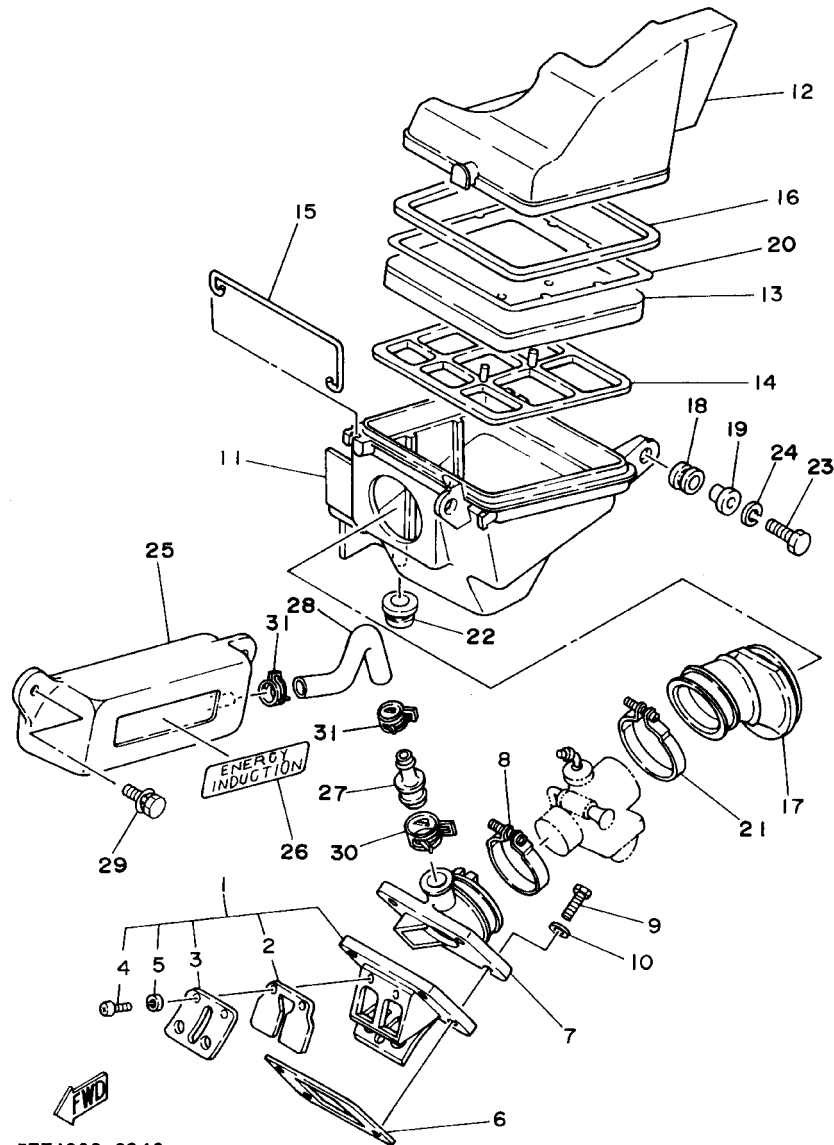

3TT4200-6040

REF. NO.	PART NO. CODIGO NO.	DESCRIPTION DESCRIPTION	3TT7	3TT8	3TS9	3TSA	REMARKS OBSERVACION
1	10V-13610-01	REED VALVE ASSY VALVULA DE LAMINAS COMPLETA	1	1	1	1	
2	10V-13613-01	.REED, VALVE .VALVULA DE LAMINAS	2	2	2	2	
3	10V-13616-01	.STOPPER, REED VALVE .TOPE DE VALVULA DE LAMINAS	2	2	2	2	
4	98507-03008	.SCREW .TORNILLO DE CABEZA CON PLANA	4	4	4	4	
5	92907-03100	.WASHER ARANDELA	4	4	4	4	
6	3TT-13621-00	GASKET, VALVE SEAT JUNTA, DE VALV.DE EMPAQUE	1	1	1	1	
7	10V-13565-01	JOINT, CARBURETOR TOBERA, DE ADMISION	1	1	1	1	
8	90450-44046	HOSE CLAMP ASSY BRIDA, MANGUERA	1	1	1	1	
9	97007-06025	BOLT PERNO	4	4	4	4	
10	92907-06600	WASHER, PLATE ARANDELA	4	4	4	4	
11	18G-14411-00	CASE, AIR CLEANER 1 CAJA FILTRO DEL AIRE 1	1	1	1	1	
12	18G-14412-00	CAP, CLEANER CASE 1 TAPA CAJA DEL FILTRO 1	1	1	1	1	
13	3TK-14451-00	ELEMENT, AIR CLEANER ELEMENTO DEL FILTRO DEL AIRE	1	1	1	1	
14	18G-14458-00	GUIDE GUIA	1	1	1	1	
15	18G-14493-00	STAY 1 SOPORTE 1	2	2	2	2	
16	18G-14452-00	SEAL SELLO	1	1	1	1	
17	18G-14453-01	JOINT, AIR CLEANER 1 UNION DEL FILTRO DEL AIRE 1	1	1	1	1	
18	90480-14102	GROMMET TAPON	2	2	2	2	
19	90387-07391	COLLAR COLLAR	2	2	2	2	
20	3TK-14472-00	PLATE, ELEMENT PLACA DE ELEMENTO	1	1	1	1	
21	90460-49058	CLAMP, HOSE BRIDA, DE UNION	1	1	1	1	
22	90480-18171	GROMMET TAPON	1	1	1	1	
23	97007-06025	BOLT PERNO	2	2	2	2	
24	92907-06100	WASHER, SPRING ARANDELA	2	2	2	2	
25	18G-13581-00	CHAMBER, AIR CAMARA DE AIRE	1	1	1	1	
26	18G-1441K-00	EMBLEM EMBLEMA	1	1	1	1	
27	18G-13584-00	PIPE, INTAKE MANIFOLD TUBO MULTIPLE	1	1	1	1	

FIG. 5 CARBURETOR

CARBURADOR

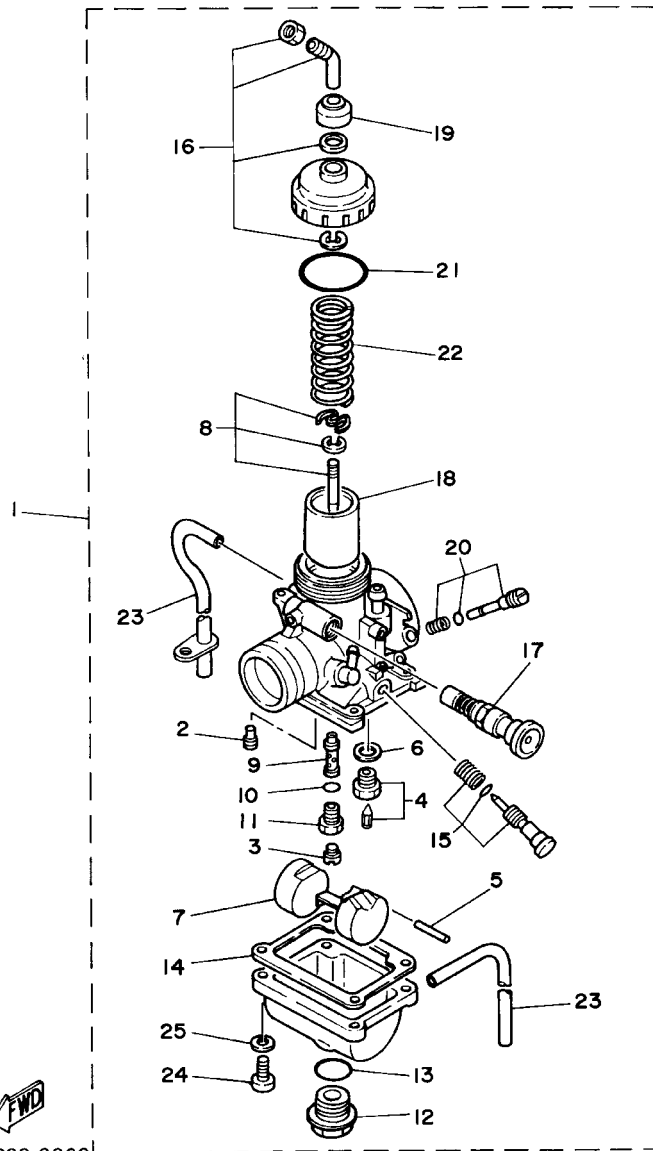

FWD
3TSI200-0060

REF. NO.	PART NO. CODIGO NO.	DESCRIPTION DESCRIPTION	3TT7	3TT8	3TS9	3TSA	REMARKS OBSERVACION
1	18G-14101-00	CARBURETOR ASSY 1 CARBURADOR COMPLETO 1	1	1			
	18L-14101-00	CARBURETOR ASSY 1 CARBURADOR COMPLETO 1			1	1	
2	260-14142-22	.JET, PILOT (# 22.5) .SURTIDOR DE RALENTI (# 22.5)	1	1			
	260-14142-20	.JET, PILOT (# 20) .SURTIDOR DE RALENTI (# 20)			1	1	
3	137-14143-33	.JET, MAIN (#165) .SURTIDOR, PRINCIPAL (#165)	1	1			
	137-14143-34	.JET, MAIN (#170) .SURTIDOR, PRINCIPAL (#170)			1	1	STD
	137-14143-33	.JET, MAIN (#165) .SURTIDOR, PRINCIPAL (#165)			1	1	AP
	137-14143-35	.JET, MAIN (#175) .SURTIDOR, PRINCIPAL (#175)			1	1	AP
4	10V-14190-20	.NEEDLE VALVE ASSY .VALVULA DE OBTURACION	1	1			
	1V0-14190-25	.NEEDLE VALVE ASSY .VALVULA DE OBTURACION			1	1	
5	127-14186-00	.PIN, FLOAT .PASADOR DE LA BOYA	1	1	1	1	
6	214-14195-00	.WASHER, NEEDLE VALVE .ARANDELA DE VALVULA DE AGUJA	1	1	1	1	
7	314-14185-00	.FLOAT .BOYA	1	1	1	1	
8	18G-1490J-00	.NEEDLE SET .CJTO. AGUJA	1	1			
	18L-1490J-00	.NEEDLE SET .CJTO. AGUJA			1	1	
9	2F5-14141-36	.NOZZLE, MAIN .BOQUILLA PRINCIPAL	1	1			
	2F5-14141-38	.NOZZLE, MAIN .BOQUILLA PRINCIPAL			1	1	
10	214-14147-00	.O-RING .ANILLO O	1	1	1	1	
11	2N4-14145-00	.HOLDER .ESPREA	1	1	1	1	
12	500-14115-00	.PLUG, SCREW .TAPON DE TORNILLO	1	1	1	1	
13	558-14147-00	.O-RING .ANILLO O	1	1	1	1	
14	304-14184-00	.GASKET, FLOAT CHAMBER .JUNTA, CAMARA DE FLOT	1	1	1	1	
15	18G-14103-00	.THROTTLE SCREW SET .CJTO. TORNILLO DEL RALENTI	1	1	1	1	
16	10X-14106-00	.CABLE ADJUST SCREW SET .TORNILLO AJUSTADOR DE CABLE	1	1	1	1	
17	4U5-14171-00	.PLUNGER, STARTER .EMBOLO DE ARRANQUE	1	1	1	1	
18	314-14112-25	.VALVE, THROTTLE .VALVULA DE ACELERACION 1	1	1	1	1	
19	1M1-14169-00	.CAP .FUNDA	1	1	1	1	

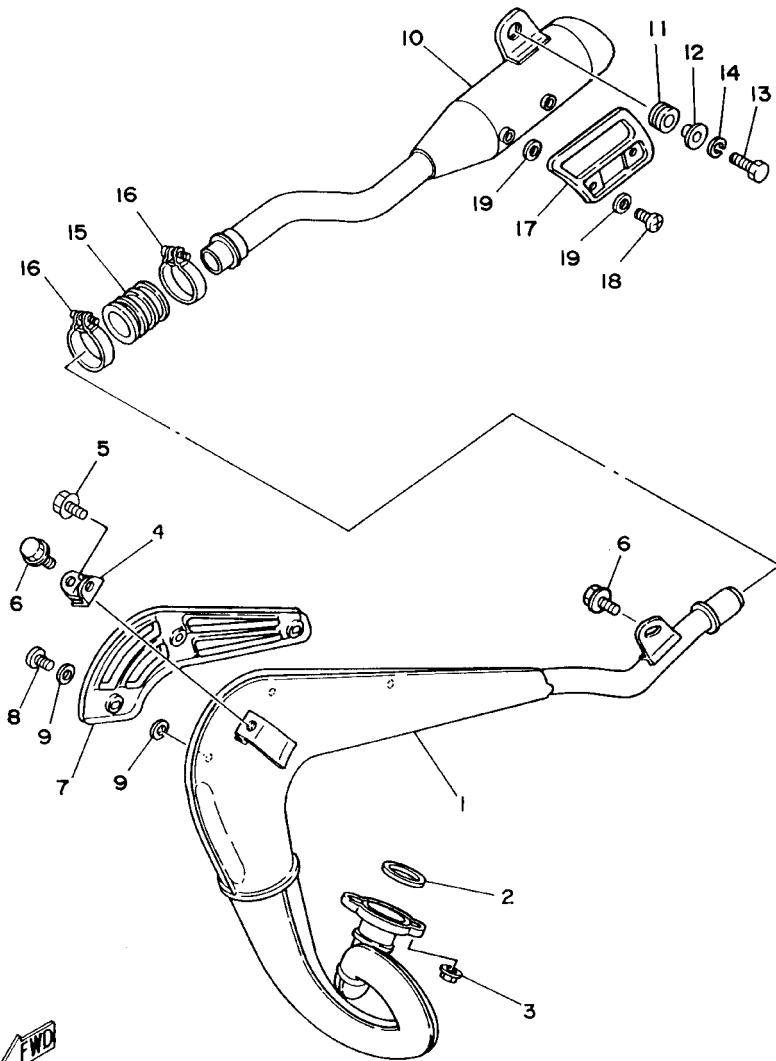

3FJ5700-2060

FIG. 6 EXHAUST

DESCARGA

REF. NO.	PART NO. CODIGO NO.	DESCRIPTION DESCRIPTION	3TT7	3TT8	3TS9	3TSA	REMARKS OBSERVACION
1	18G-14610-01	EXHAUST PIPE ASSY 1 TUBO DE ESCAPE COMPLETO 1	1	1			
	18L-14610-01	EXHAUST PIPE ASSY 1 TUBO DE ESCAPE COMPLETO 1			1	1	
2	3PA-14613-10	GASKET, EXHAUST PIPE JUNTA, TUBO DE ESCAPE	1	1	1	1	
3	95707-06500	NUT, FLANGE TUERCA DE BRIDA	2	2	2	2	
4	2A6-14772-00	STAY, MUFFLER 2 SOPORTE DE SILENCIADOR 2	1	1	1	1	
5	95807-08012	BOLT, FLANGE TUERCA DE REBORDE	1	1	1	1	
6	95027-08012	BOLT, FLANGE PERNO, DE BRIDA	2	2	2	2	
7	18G-14718-00	PROTECTOR, MUFFLER 1 PROTECTOR DE SILENCIADOR 1	1	1	1	1	
8	98907-06008	SCREW, BIND TORNILLO DE LIGAR	3	3	3	3	
9	90202-05187	WASHER, PLATE ARANDELA DE PLANA	6	6	6	6	
10	18G-14753-00	SILENCER, EXHAUST SILENCIADOR DE ESCAPE	1	1	1	1	
11	168-21638-00	DAMPER 1 AMORTIGUADOR 1	1	1	1	1	
12	90387-093H1	COLLAR COLLAR	1	1	1	1	
13	97507-08625	BOLT, WITH WASHER PERNO CON ARANDELA RONDELLE	1	1	1	1	
14	92907-08100	WASHER, SPRING ARANDELA	1	1	1	1	
15	1W2-14714-00	GASKET, MUFFLER EMPAQUE DE SILENCIADOR	1	1	1	1	
16	90460-37026	CLAMP, HOSE BRIDA, DE UNION	2	2	2	2	
17	10V-14758-00	PROTECTOR, SILENCER PROTECTOR DE SILENCIADOR	1	1	1	1	
18	98907-06008	SCREW, BIND TORNILLO DE LIGAR	2	2	2	2	
19	90202-05187	WASHER, PLATE ARANDELA DE PLANA	4	4	4	4	

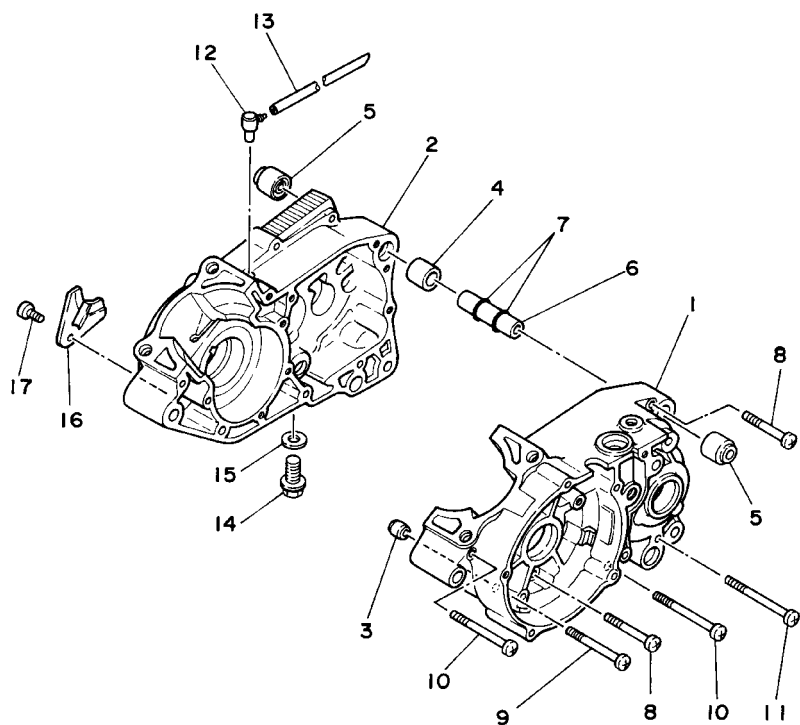
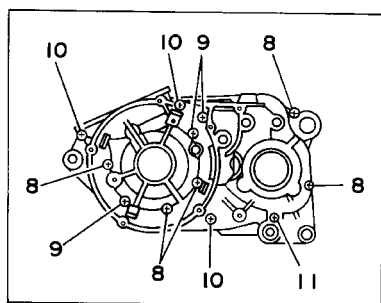

3TT1200-0070

FIG. 7 CRANKCASE

CARTER

REF. NO.	PART NO. CODIGO NO.	DESCRIPTION DESCRIPTION	3TT7	3TT8	3TS9	3TSA	REMARKS OBSERVACION
1	2A6-15111-03	CRANKCASE 1	1	1			
	18L-15111-01	CARTER MANIVELA 1			1	1	
2	2A6-15121-02	CRANKCASE 2	1	1			
	18L-15121-01	CARTER MANIVELA 2			1	1	
3	99530-10114	PIN, DOWEL PASADOR, DE CLAVIJA	1	1	1	1	
4	99530-20020	PIN, DOWEL PASADOR, DE CLAVIJA	1	1	1	1	
5	328-15316-00	DAMPER, ENGINE MOUNT 1 AMORT. MONTANTE MOTOR 1	2	2	2	2	
6	401-15317-00	SPACER, ENGINE MOUNT SEPARADPR, MONTANTE DE MOTOR	1	1	1	1	
7	93210-11073	O-RING JUNTA TORICA	2	2	2	2	
8	98507-06050	SCREW, PAN HEAD TORNILLO DE CABEZA CON PLANA	5	5	5	5	
9	98507-06060	SCREW, PAN HEAD TORNILLO DE CABEZA CON PLANA	3	3	3	3	
10	98507-06070	SCREW, PAN HEAD TORNILLO DE CABEZA CON PLANA	3	3	3	3	
11	98507-06075	SCREW, PAN HEAD TORNILLO DE CABEZA CON PLANA	1	1	1	1	
12	2N4-15371-00	BREATHER RESPIRADERO	1	1	1	1	
13	90445-07340	HOSE (L310) TUBO (L310)	1	1	1	1	
14	90340-12005	PLUG, STRAIGHT SCREW TORNILLO, DE DRENAJE	1	1	1	1	
15	90430-12227	GASKET JUNTA	1	1	1	1	
16	304-15128-00	HOLDER SOPORTE	1	1	1	1	
17	90157-08131	SCREW, PAN HEAD TORNILLO CABEZA CONICA PLANA	1	1	1	1	

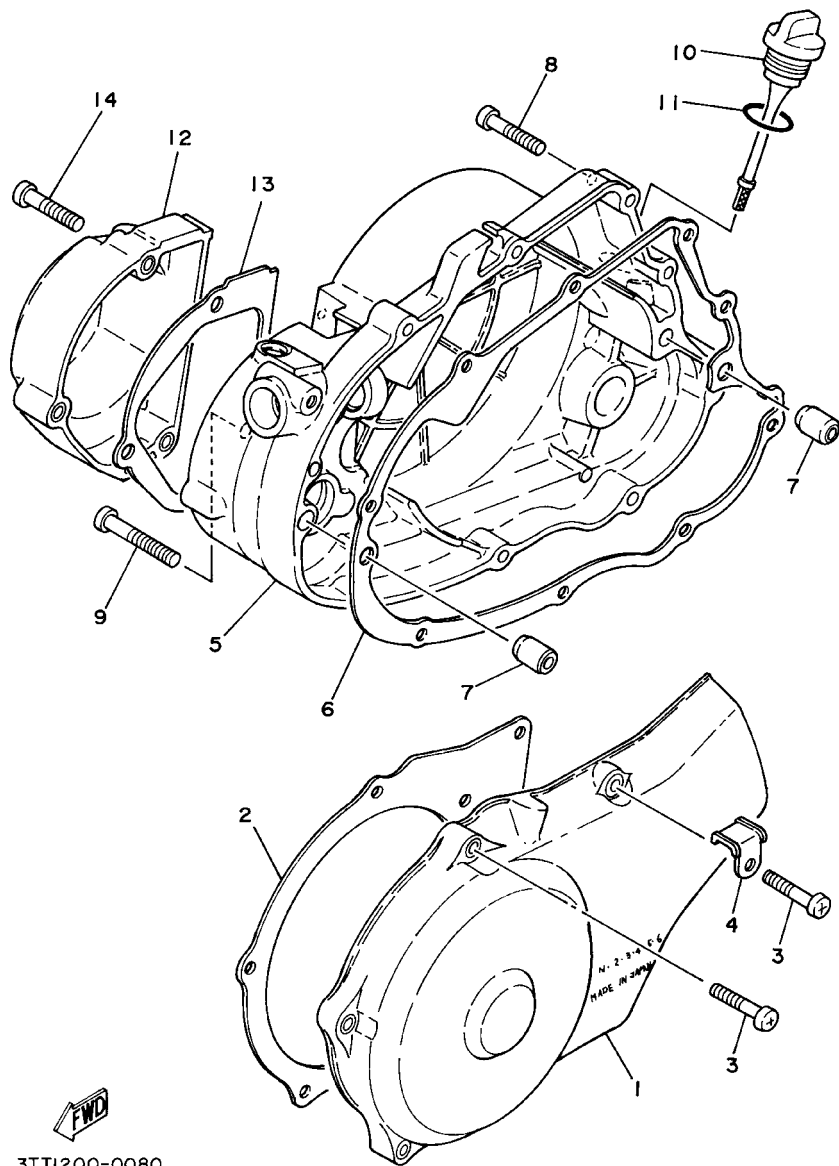

3TTI200-0080

FIG. 8 CRANKCASE COVER 1

CUBIERTA DE CARTER 1

REF. NO.	PART NO. CODIGO NO.	DESCRIPTION DESCRIPTION	3TT7	3TT8	3TS9	3TSA	REMARKS OBSERVACION
1	2A7-15411-01	COVER, CRANKCASE 1 CUBIERTA DE CARTER 1	1	1	1	1	
2	2A6-15455-01	GASKET 1 EMPAQUE 1	1	1	1	1	
3	98507-06025	SCREW, PAN HEAD TORNILLO DE CABEZA CON PLANA	6	6	6	6	
4	2A6-15484-01	CLAMP 2 GRAMPA 2	1	1	1	1	
5	18G-15431-01	COVER, CRANKCASE 3 CUBIERTA DE CARTER 3	1	1	1	1	
6	18G-15451-03	GASKET, CRANKCASE COVER 1 EMPAQ DE CUBIERTA DE CARTER 1	1	1	1	1	
7	99530-10114	PIN, DOWEL PASADOR, DE CLAVIJA	2	2	2	2	
8	98507-06030	SCREW, PAN HEAD TORNILLO DE CABEZA CON PLANA	8	8	8	8	
9	98507-06040	SCREW, PAN HEAD TORNILLO DE CABEZA CON PLANA	1	1	1	1	
10	18G-15362-00	PLUG, OIL LEVEL TAPON DEL NIVEL DE ACEITE	1	1	1	1	
11	93210-21190	O-RING JUNTA TORICA	1	1	1	1	
12	18G-15416-00	COVER, OIL PUMP CUBIERTA DE BOMBA DE ACEITE	1	1	1	1	
13	18G-15456-02	GASKET, OIL PUMP COVER 1 EMPAQ CUBTA.BOMBA ACEITE 1	1	1	1	1	
14	98507-06030	SCREW TORNILLO DE CABEZA CON PLANA	3	3	3	3	

FIG. 9 STARTER

ARRANQUE

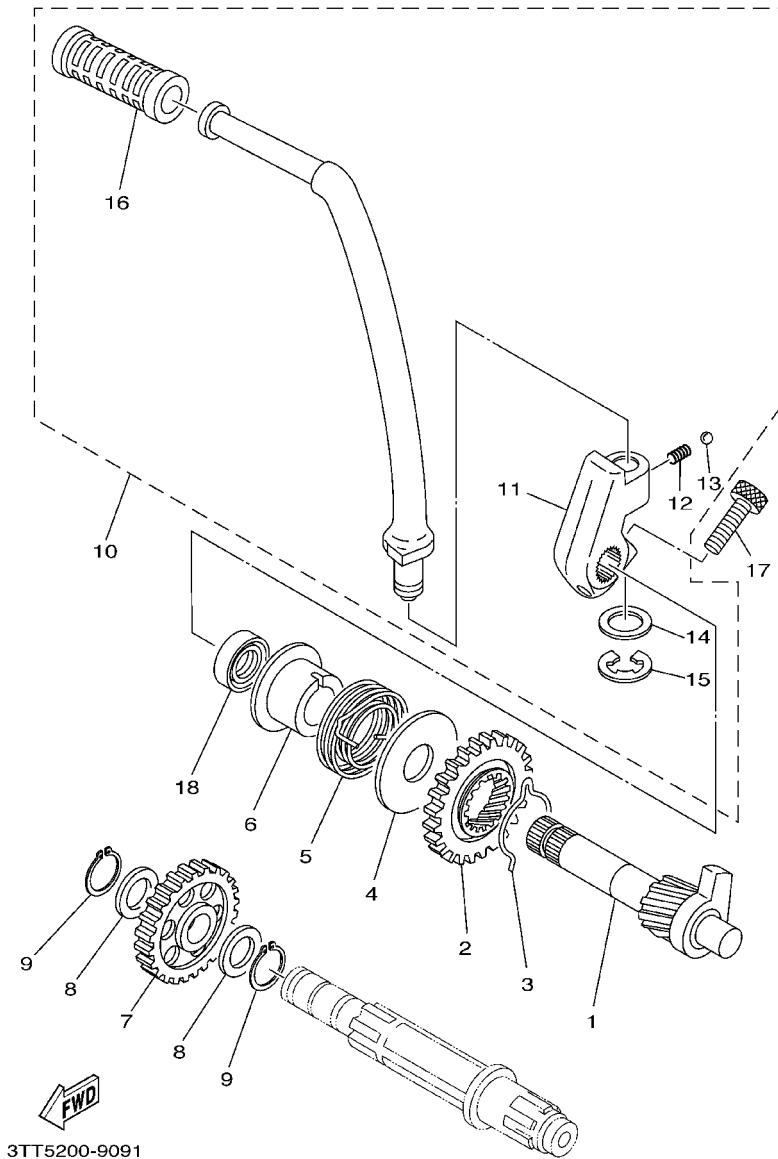

3TT5200-9091

REF. NO.	PART NO. CODIGO NO.	DESCRIPTION DESCRIPTION	3TT7	3TT8	3TS9	3TSA	REMARKS OBSERVACION
1	4F2-15660-01	KICK AXLE ASSY EJE DEL PEDAL DE ARRAN.COMPLET	1	1	1	1	
2	1W1-15641-00	GEAR, KICK (27T) ENGRANAJE, PEDAL ARRANQUE (27T)	1	1	1	1	
3	90468-26048	CLIP PRESILLA	1	1			
	90468-26183	CLIP PRESILLA			1	1	
4	401-15676-00	COVER, SPRING CUBIERTA DE RESORTE	1	1	1	1	
5	90508-26450	SPRING, TORSION RESORTE DE TORSION	1	1	1	1	
6	1W1-15666-00	SPACER SEPARADOR	1	1	1	1	
7	525-15651-00	GEAR, KICK IDLE (25T) PINON LIBRE, PEDAL ARRANQUE (25T)	1	1	1	1	
8	137-17417-00-05	SHIM 1 (T=0.5) ARANDELA DE REGLAJE (T=0.5)	2	2	2	2	
9	93440-15012	CIRCLIP SEGURO	2	2	2	2	
10	2A6-15620-02	KICK CRANK ASSY MANIVELA DE PEDAL COMPLETA	1	1	1	1	
11	1W1-15621-01	.BOSS, KICK CRANK .COPA DE MANIVELA DE PEDAL	1	1	1	1	
12	90501-10459	.SPRING, COMPRESSION .RESORTE DE COMPRESION	1	1	1	1	
13	93503-16003	.BALL .ESFERA	1	1	1	1	
14	90201-12541	.WASHER, PLATE .ARANDELA PLANA	1	1	1	1	
15	93430-08007	.CIRCLIP .SEGURO	1	1	1	1	
16	156-15618-01	.COVER, KICK LEVER .GOMA PROTECTORA, PEDAL	1	1	1	1	
17	91317-08025	BOLT PERNO	1	1	1	1	
18	93101-17062	OIL SEAL RETEN DE ACEITE	1	1	1	1	

EMBRAGUE

FIG. 10 CLUTCH

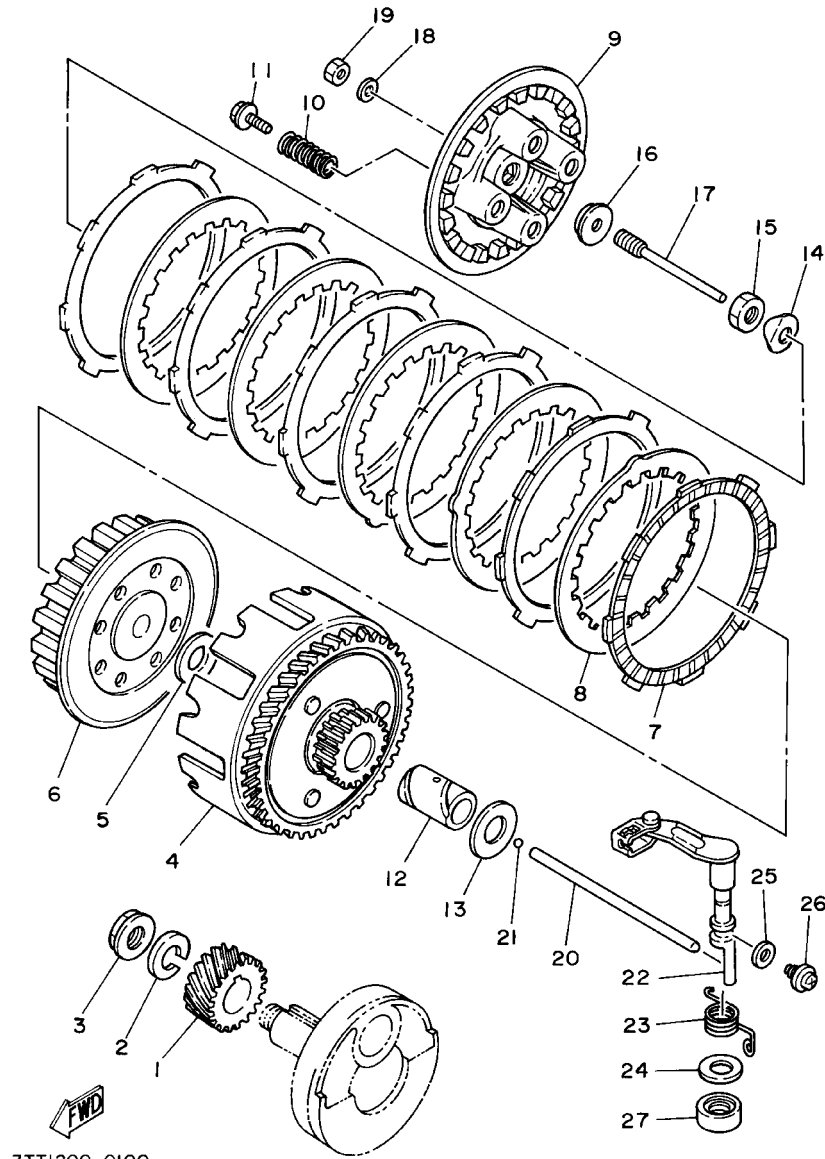

3TT1200-0100

REF. NO.	PART NO. CODIGO NO.	DESCRIPTION DESCRIPTION	3TT7	3TT8	3TS9	3TSA	REMARKS OBSERVACION
1	2JK-16111-01	GEAR, PRIMARY DRIVE (22T) ENGRANAJE TRACC.PRIMARIA (22T)	1	1	1	1	
2	90204-12007	WASHER, SPRING ARANDELA DE RESORTE	1	1	1	1	
3	90179-12659	NUT TUERCA	1	1	1	1	
4	3TL-16150-00	PRIMARY DRIVEN GEAR COMP. CAMPANA DE EMBRAGUE	1	1	1	1	
5	90201-17550	WASHER, PLATE ARANDELA PLANA	1	1	1	1	
6	18G-16371-00	BOSS, CLUTCH CUBO, DE EMBRAGUE	1	1			
	18L-16371-00	BOSS, CLUTCH CUBO, DE EMBRAGUE			1	1	
7	598-16321-01	PLATE, FRICTION PLACA DE FRICCION	6	6	7	7	
8	1V1-16324-00	PLATE, CLUTCH 1 PLACA DE EMBRAGUE 1	5	5	6	6	
9	18G-16351-00	PLATE, PRESSURE 1 PLATO DE PRESION 1	1	1	1	1	
10	90501-20568	SPRING, COMPRESSION RESORTE DE COMPRESION	4	4	4	4	
11	90119-05020	BOLT, WITH WASHER TORNILLO CON ARANDELA	4	4	4	4	
12	90560-17147	SPACER SEPARADOR	1	1	1	1	
13	90201-17550	WASHER, PLATE ARANDELA PLANA	1	1	1	1	
14	90215-14122	WASHER, LOCK ARANDELA DE CIERRE	1	1	1	1	
15	90170-14171	NUT TUERCA	1	1	1	1	
16	1W1-16358-01	PLATE, PUSH PLACA DE EMPUJE	1	1	1	1	
17	1W1-16356-02	ROD, PUSH 1 VARILLA DE EMPUJE 1	1	1	1	1	
18	92907-06200	WASHER ARANDELA	1	1	1	1	
19	95307-06600	NUT TUERCA	1	1	1	1	
20	2X3-16357-00	ROD, PUSH 2 VARILLA DE EMPUJE 2	1	1	1	1	
21	93503-16003	BALL ESFERA	1	1	1	1	
22	18G-16380-02	PUSH LEVER ASSY LEVA DE EMPUJE COMPLETA	1	1	1	1	
23	90508-20345	SPRING, TORSION RESORTE DE TORSION	1	1	1	1	
24	90201-14217	WASHER, PLATE ARANDELA PLANA	1	1	1	1	
25	90430-08216	GASKET JUNTA	1	1	1	1	
26	90149-08108	SCREW TORNILLO DE REGLAJE	1	1	1	1	

FIG. 11 TRANSMISSION

TRANSMISSION

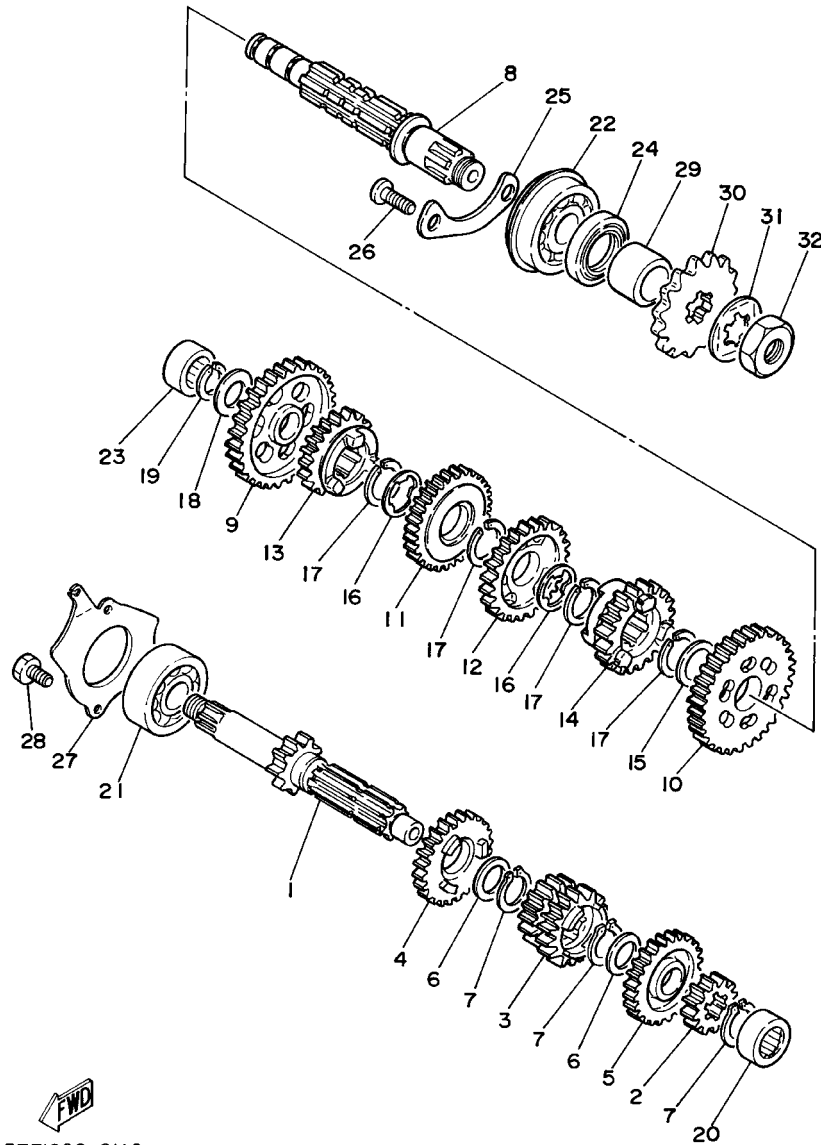

FWD
3T TI200-0110

REF. NO.	PART NO. CODIGO NO.	DESCRIPTION DESCRIPTION	3TT7	3TT8	3TS9	3TSA	REMARKS OBSERVACION
1	4J3-17411-00	AXLE, MAIN (11T) EJE PRIMARIO (11T)	1	1	1	1	
2	4J3-17121-00	GEAR, 2ND PINION (15T) ENGRANAJE DE PINON DE 2DA (15T)	1	1	1	1	
3	4J3-17131-00	GEAR, 3RD/4TH PINION (19T/22T) ENGRANAJE PINON DE 3RA/4TA (19T/22T)	1	1	1	1	
4	4J3-17151-01	GEAR, 5TH PINION (23T) ENGRANAJE PINON DE 5TA (23T)	1	1	1	1	
5	4J3-17161-00	GEAR, 6TH PINION (25T) ENGRANAJE PINON 6TA (25T)	1	1	1	1	
6	90201-20266	WASHER, PLATE (T=1.0) ARANDELA, PLACA (T=1.0)	2	2	2	2	
7	93410-20038	CIRCLIP SEGURO	3	3	3	3	
8	2A6-17421-00	AXLE, DRIVE EJE SECUNDARIO	1	1	1	1	
9	4J3-17211-00	GEAR, 1ST WHEEL (35T) ENGRANAJE RUEDA DE 1RA (35T)	1	1	1	1	
10	4J3-17221-00	GEAR, 2ND WHEEL (29T) ENGRANAJE RUEDA DE 2DA (29T)	1	1	1	1	
11	4J3-17231-00	GEAR, 3RD WHEEL (26T) ENGRANAJE RUEDA DE 3RA (26T)	1	1	1	1	
12	4J3-17241-00	GEAR, 4TH WHEEL (24T) ENGRANAJE DE RUEDA 4TA (24T)	1	1	1	1	
13	4J3-17251-00	GEAR, 5TH WHEEL (22T) ENGRANAJE RUEDA DE 5TA (22T)	1	1	1	1	
14	4J3-17261-00	GEAR, 6TH WHEEL (21T) ENGRANAJE RUEDA DE 6TA (21T)	1	1	1	1	
15	90201-22555	WASHER, PLATE ARANDELA PLANA	1	1	1	1	
16	90209-18135	WASHER ARANDELA DE SEPARACION	2	2	2	2	
17	93410-22039	CIRCLIP SEGURO	4	4	4	4	
18	90201-15700	WASHER, PLATE ARANDELA PLANA	1	1	1	1	
19	93440-15012	CIRCLIP SEGURO	1	1	1	1	
20	93311-41530	BALL BEARING COJINETE DE RODILLOS	1	1	1	1	
21	93306-30304	BEARING (B6303Z) COJINETE (B6303Z)	1	1	1	1	
22	93306-30411	BEARING (B6304) COJINETE (B6304)	1	1	1	1	
23	93311-31515	BALL BEARING COJINETE DE RODILLOS	1	1	1	1	
24	93102-26042	OIL SEAL RETEN DE ACEITE	1	1	1	1	
25	1W1-15381-00	PLATE, BEARING COVER PLACA CUBTA.RESPIRADERO	1	1	1	1	
26	98707-06012	SCREW, FLAT HEAD TORNILLO DE CABEZA PLANA	2	2	2	2	
27	1W1-17471-01	PLATE, COVER PLACA, DE CUBIERTA	1	1	1	1	

FIG. 13 SHIFT CAM. FORK

LEVA DE CAMBIO. HORQ

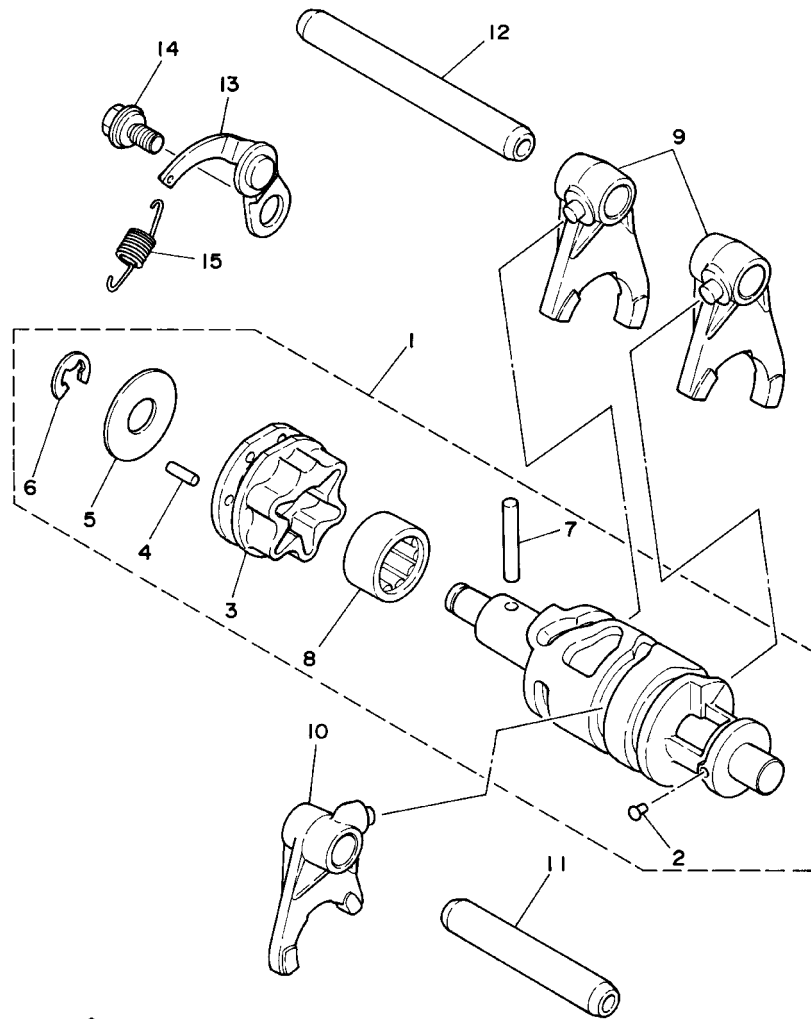

3TT1200-0130

REF. NO.	PART NO. CODIGO NO.	DESCRIPTION DESCRIPTION	3TT7	3TT8	3TS9	3TSA	REMARKS OBSERVACION
1	1W1-18540-00	SHIFT CAM ASSY LEVADEL CAMBIO COMPLETA	1	1	1	1	
2	136-18542-00	.POINT, NEUTRAL .PUNTO NEVERTO	1	1	1	1	
3	1W1-18185-00	.SEGMENT .SEGMENTO DE RETENCION	1	1	1	1	
4	93604-12037	.PIN, DOWEL .PASADOR DE CLAVIJA	6	6	6	6	
5	1W1-18561-00	.PLATE, SIDE 1 .PLACA LATERAL 1	1	1	1	1	
6	93430-08006	.CIRCLIP .SEGURO	1	1	1	1	
7	93604-30018	.PIN, DOWEL .PASADOR DE CLAVIJA	1	1	1	1	
8	93315-21813	.BEARING .COJINETE DE RODILLOS	1	1	1	1	
9	2A6-18511-00	FORK, SHIFT 1 HORQUILLA DEL CAMBIO 1	2	2	2	2	
10	2A6-18512-00	FORK, SHIFT 2 HORQUILLA DEL CAMBIO 2	1	1	1	1	
11	2A6-18531-00	BAR, SHIFT FORK GUIDE 1 BARRA GUIA HORQ. CAMBIO 1	1	1	1	1	
12	2A6-18535-00	BAR, SHIFT FORK GUIDE 2 BARRA GUIA HORQ. CAMBIO 2	1	1	1	1	
13	1W1-18140-00	STOPPER LEVER ASSY PALANCA DE TOPE COMPLETA	1	1	1	1	
14	90109-063F7	BOLT PERNO	1	1	1	1	
15	90506-09156	SPRING, TENSION RESORTE DE TENSION	1	1	1	1	

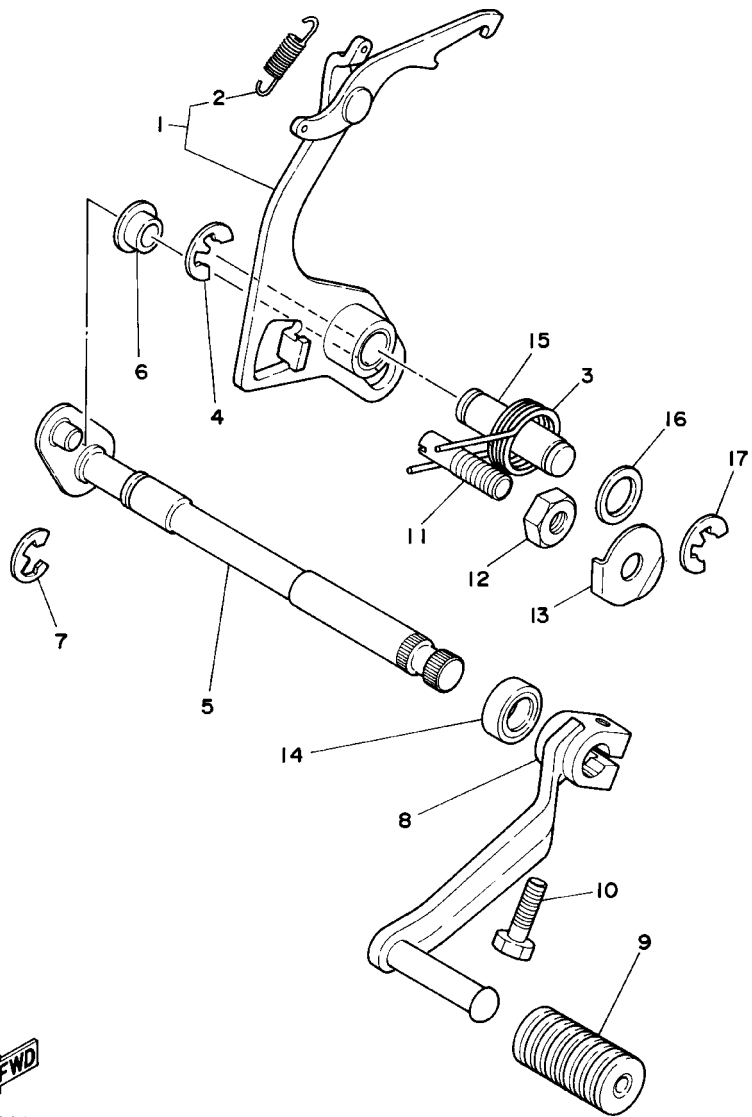

3TT1200-0140

FIG. 14 SHIFT SHAFT

EJE DE CAMBIO. PEDAL

REF. NO.	PART NO. CODIGO NO.	DESCRIPTION DESCRIPTION	3TT7	3TT8	3TS9	3TSA	REMARKS OBSERVACION
1	4F2-18120-00	SHIFT LEVER ASSY PALANCA DE SELECTOR COMPLETO	1	1	1	1	
2	90506-08155	SPRING, TENSION RESORTE DE TENSION	1	1	1	1	
3	90508-32349	SPRING, TORSION RESORTE DE TORSION	1	1	1	1	
4	99001-10600	CIRCLIP PRESILLA REDONDA	1	1	1	1	
5	4F2-18101-02	SHIFT SHAFT ASSY EJE SELECTOR COMPLETO	1	1	1	1	
6	401-18178-00	ROLLER, SHIFT LEVER RODILLO DE PALANCA DE CAMBIOS	1	1	1	1	
7	99001-10600	CIRCLIP PRESILLA REDONDA	1	1	1	1	
8	2A6-18111-00	PEDAL, SHIFT PEDAL DEL CAMBIO	1	1	1	1	
9	132-18113-01	COVER, SHIFT PEDAL FUNDA DEL PEDAL DEL CAMBIO	1	1	1	1	
10	97027-06020	BOLT PERNO	1	1	1	1	
11	90149-08111	SCREW TORNILLO DE REGLAJE	1	1	1	1	
12	90170-08029	NUT TUERCA	1	1	1	1	
13	90215-08014	WASHER, LOCK ARANDELA DE CIERRE	1	1	1	1	
14	93101-12173	OIL SEAL RETEN DE ACEITE	1	1	1	1	
15	1W1-18197-01	SHAFT EJE	1	1	1	1	
16	90201-12163	WASHER, PLATE ARANDELA PLANA	1	1	1	1	
17	99001-10600	CIRCLIP PRESILLA REDONDA	1	1	1	1	

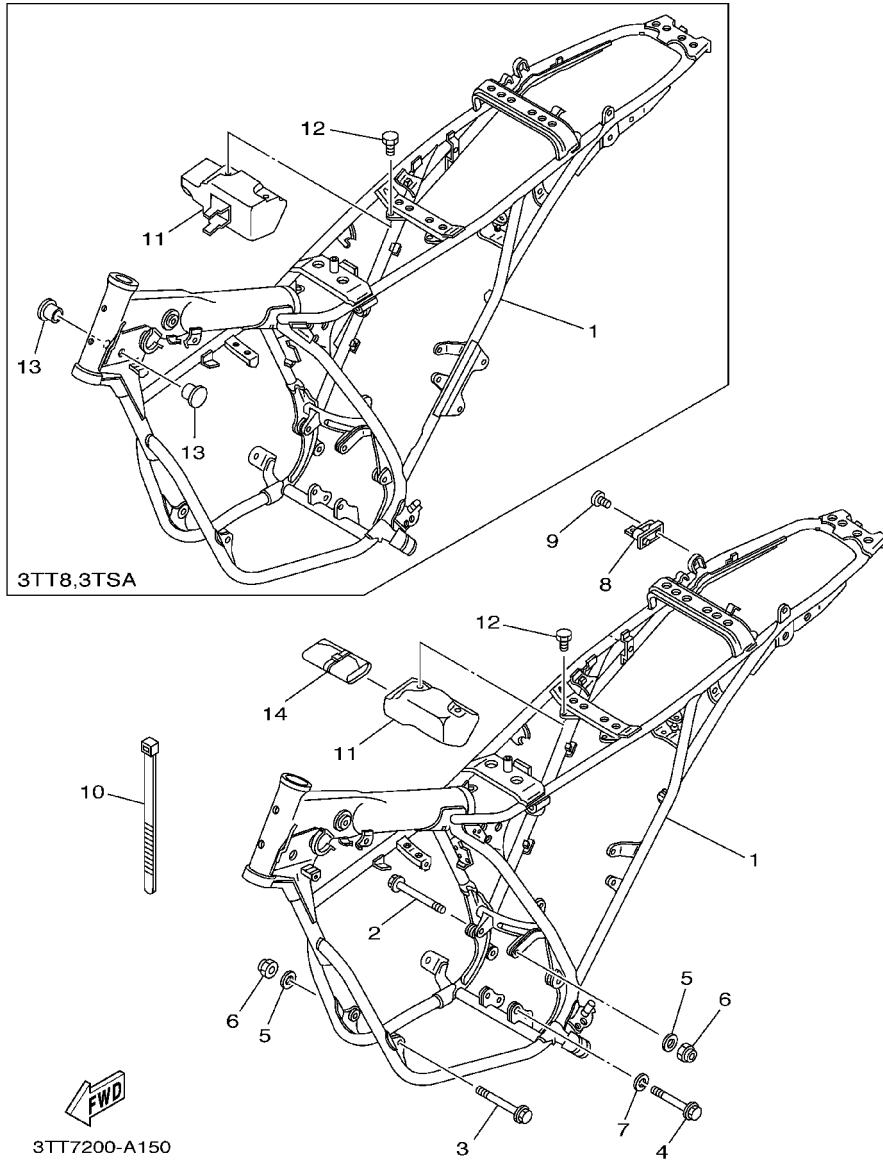

FIG. 15 FRAME

CUADRO

REF. NO.	PART NO. CODIGO NO.	DESCRIPTION DESCRIPTION	3TT7	3TT8	3TS9	3TSA	REMARKS OBSERVACION
1	3TT-21110-01-33	FRAME COMP. ARMAZON COMPLETO	1				UR YB FOR BWC1, VRC7,CM3
	3TT-21110-01-P2	FRAME COMP. ARMAZON COMPLETO	1				UR DPBMC
	3TT-21110-10-33	FRAME COMP. ARMAZON COMPLETO		1			UR YB FOR BWC1, VRC7,CM3
	3TT-21110-10-P0	FRAME COMP. ARMAZON COMPLETO		1			UR DPBMC
	3TS-21110-01-33	FRAME COMP. ARMAZON COMPLETO			1		UR YB FOR BWC1, VRC7,CM3
	3TS-21110-01-P2	FRAME COMP. ARMAZON COMPLETO			1		UR DPBMC
	3TS-21110-10-33	FRAME COMP. ARMAZON COMPLETO				1	UR YB FOR BWC1, VRC7,CM3
	3TS-21110-10-P0	FRAME COMP. ARMAZON COMPLETO				1	UR DPBMC
2	90105-08099	BOLT, FLANGE TORNILLO	1	1	1	1	
3	90105-08120	BOLT, FLANGE TORNILLO	1	1	1	1	
4	90105-10037	BOLT, FLANGE TORNILLO	1	1	1	1	
5	92907-08200	WASHER ARANDELA	2	2	2	2	
6	90185-08089	NUT, SELF-LOCKING TUERCA AUTOBLOCANTE	2	2	2	2	
7	92907-10100	WASHER, SPRING ARANDELA	1	1	1	1	
8	5G3-21308-01	HELMET HANGER ASSY PORTACASCO COMPLETO	1				
	5H0-21308-01	HELMET HANGER ASSY PORTACASCO COMPLETO		1		1	
9	98707-06020	SCREW, FLAT HEAD TORNILLO DE CABEZA PLANA	1	1	1	1	
10	90464-16061	CLAMP BRIDA	1		1		
	5Y9-12491-00	CLAMP 1 GRAMPA 1		1		1	
11	3J0-21170-01	BOX COMP. CAJA COMPLETA	1		1		
	3TT-21107-00	TOOL BOX COMP. CAJA DE HERRAMIENTAS COMPL.		1		1	
12	90101-06529	BOLT TORNILLO	2	2	2	2	
13	90338-18122	PLUG TAPON		2		2	
14	2A6-28100-00	TOOL KIT JUEGO DE HERRAMIENTAS	1		1		
	2A6-28100-10	TOOL KIT JUEGO DE HERRAMIENTAS		1		1	

FIG. 16 FENDER

GUARDABARRO

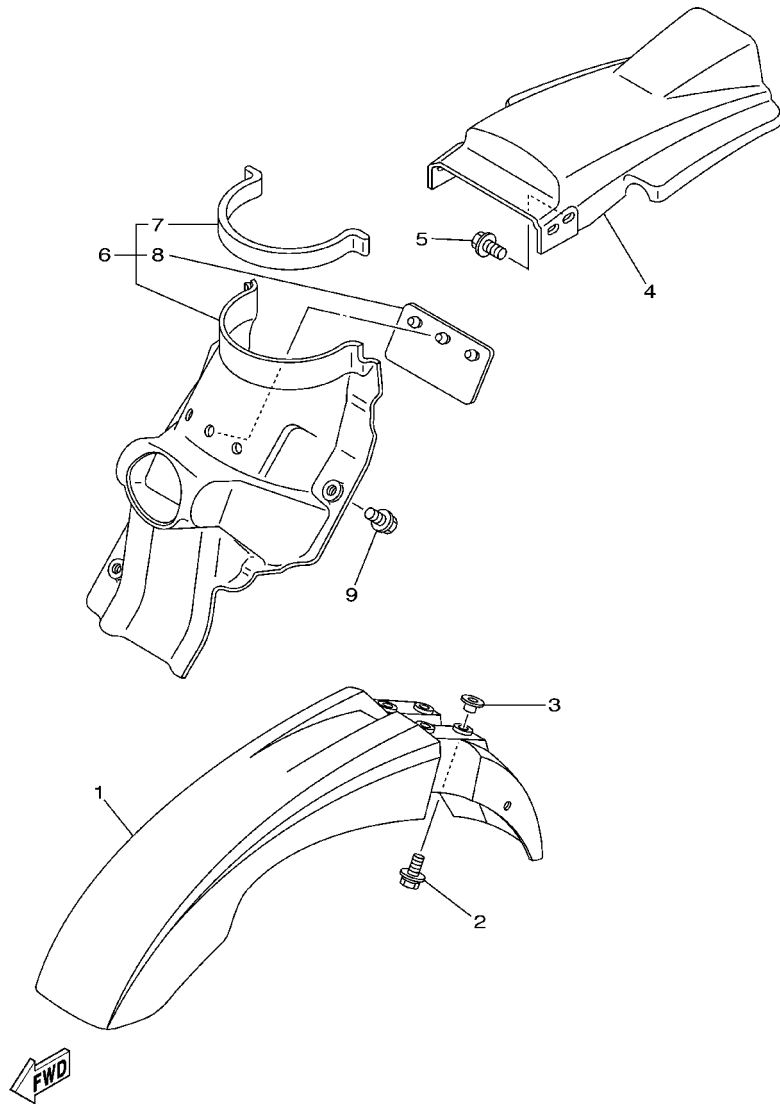

3TT5200-9160

REF. NO.	PART NO. CODIGO NO.	DESCRIPTION DESCRIPTION	3TT7	3TT8	3TS9	3TSA	REMARKS OBSERVACION
1	37N-21511-30	FENDER, FRONT GUARDABARRO DELANTERO	1		1		UR PWS1 FOR BWC1, VRC7
	37N-21511-20	FENDER, FRONT GUARDABARRO DELANTERO	1		1		UR YB FOR CM3
	37N-21511-60	FENDER, FRONT GUARDABARRO DELANTERO	1		1		UR DPBSE FOR DPBMC
	3RW-21511-60	FENDER, FRONT GUARDABARRO DELANTERO		1			UR PWS1 FOR BWC1, VRC7
	3RW-21511-70	FENDER, FRONT GUARDABARRO DELANTERO		1			UR YB FOR CM3
	3RW-21511-80	FENDER, FRONT GUARDABARRO DELANTERO		1			UR DPBSE FOR DPBMC
	4BE-21511-00	FENDER, FRONT GUARDABARRO DELANTERO				1	UR PWS1 FOR BWC1, VRC7
	4BE-21511-20	FENDER, FRONT GUARDABARRO DELANTERO				1	UR YB FOR CM3
	4BE-21511-10	FENDER, FRONT GUARDABARRO DELANTERO				1	UR DPBSE FOR DPBMC
2	90119-06063	BOLT, WITH WASHER TORNILLO CON ARANDELA	4	4	4	4	
3	90387-07789	COLLAR COLLAR	4		4		
	90387-06681	COLLAR COLLAR		4		4	
4	37N-21611-20	FENDER, REAR GUARDABARRO TRASERO	1	1	1	1	UR YB FOR BWC1,CM3
	37N-21611-50	FENDER, REAR GUARDABARRO TRASERO	1	1	1	1	UR PWS1 FOR VRC7, DPBMC
5	90119-06044	BOLT, WITH WASHER TORNILLO CON ARANDELA	4	4	4	4	
6	18G-21620-00	MUD GUARD COMP. GUARDAFANGO COMPLETO	1		1		
	18G-21620-10	MUD GUARD COMP. GUARDAFANGO COMPLETO		1		1	
7	2A6-21639-00	.DAMPER 2 .AMORTIGUADOR 2	1	1	1	1	
8	1M1-21621-00	.FLAP .CHARNELA	1	1	1	1	
9	90119-06044	BOLT, WITH WASHER TORNILLO CON ARANDELA	3	3	3	3	

FIG. 17 SIDE COVER

CUBIERTA LATERAL

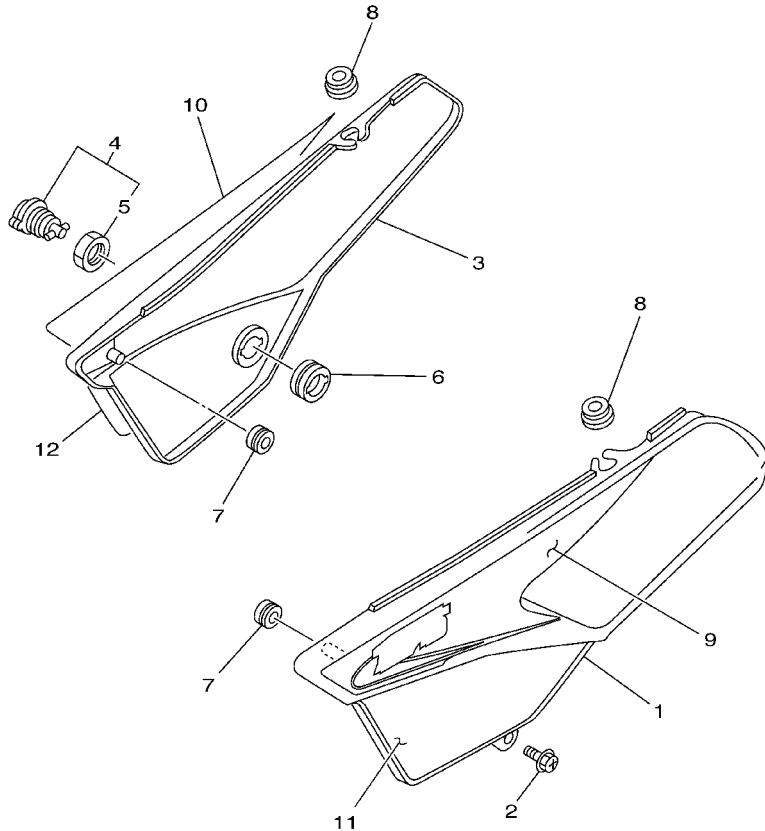

REF. NO.	PART NO. CODIGO NO.	DESCRIPTION DESCRIPTION	3TT7	3TT8	3TS9	3TSA	REMARKS OBSERVACION
1	18G-21711-20	COVER, SIDE 1 JUEGO DE GRAFICOS 1	1	1	1	1	UR YB FOR BWC1,CM3
	18G-21711-10	COVER, SIDE 1 JUEGO DE GRAFICOS 1	1	1	1	1	UR PWS1 FOR VRC7, DPBMC
2	90159-06013	SCREW, WITH WASHER TORNILLO CON VALONA	1	1	1	1	
3	18G-21721-20	COVER, SIDE 2 JUEGO DE GRAFICOS 2	1	1	1	1	UR YB FOR BWC1,CM3
	18G-21721-10	COVER, SIDE 2 JUEGO DE GRAFICOS 2	1	1	1	1	UR PWS1 FOR VRC7, DPBMC
4	4L8-21708-00	LOCK ASSY 2 CUBIERTA 2	1				
	3TT-21708-00	LOCK ASSY 2 CUBIERTA 2		1		1	
5	90170-22187	.NUT .TUERCA	1	1	1	1	
6	90480-24186	GROMMET TAPON	1	1	1	1	
7	90480-12053	GROMMET TAPON	2	2	2	2	
8	90480-13197	GROMMET TAPON	2	2	2	2	
9	3TT-2173E-A0	GRAPHIC 1 GRAFICO 1	1	1			UR FOR BWC1
	3TT-2173E-B0	GRAPHIC 1 GRAFICO 1	1	1			UR FOR VRC7
	3TT-2173E-C0	GRAPHIC 1 GRAFICO 1	1	1			UR FOR CM3
	3TT-2173E-D0	GRAPHIC 1 GRAFICO 1	1	1			UR FOR DPBMC
	3TS-2173E-A0	GRAPHIC 1 GRAFICO 1			1	1	UR FOR BWC1
	3TS-2173E-B0	GRAPHIC 1 GRAFICO 1			1	1	UR FOR VRC7
	3TS-2173E-C0	GRAPHIC 1 GRAFICO 1			1	1	UR FOR CM3
	3TS-2173E-D0	GRAPHIC 1 GRAFICO 1			1	1	UR FOR DPBMC
10	3TT-2173F-A0	GRAPHIC 2 GRAFICO 2	1	1			UR FOR BWC1
	3TT-2173F-B0	GRAPHIC 2 GRAFICO 2	1	1			UR FOR VRC7
	3TT-2173F-C0	GRAPHIC 2 GRAFICO 2	1	1			UR FOR CM3
	3TT-2173F-D0	GRAPHIC 2 GRAFICO 2	1	1			UR FOR DPBMC
	3TS-2173F-A0	GRAPHIC 2 GRAFICO 2			1	1	UR FOR BWC1
	3TS-2173F-B0	GRAPHIC 2 GRAFICO 2			1	1	UR FOR VRC7
	3TS-2173F-C0	GRAPHIC 2 GRAFICO 2			1	1	UR FOR CM3
	3TS-2173F-D0	GRAPHIC 2 GRAFICO 2			1	1	UR FOR DPBMC



3TT7200-A170

FIG. 17 SIDE COVER

CUBIERTA LATERAL

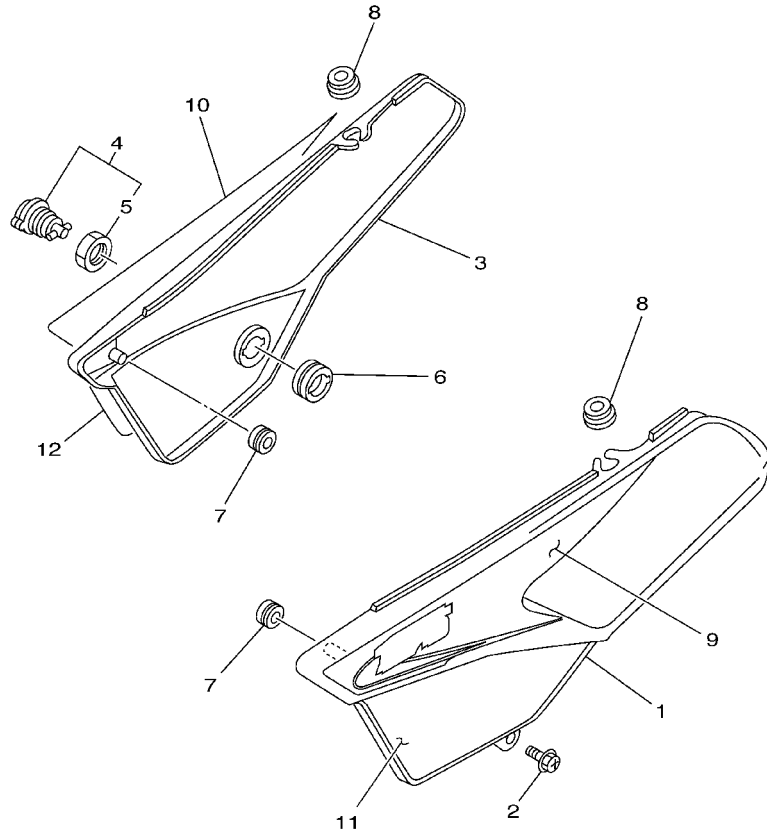

REF. NO.	PART NO. CODIGO NO.	DESCRIPTION DESCRIPTION	3TT7	3TT8	3TS9	3TSA	REMARKS OBSERVACION
11	3TT-2174G-00	GRAPHIC 3 GRAFICO 3	1	1	1	1	FOR VRC7,DPBMC
12	3TT-2174H-00	GRAPHIC 4 GRAFICO 4	1	1	1	1	FOR VRC7,DPBMC

3TT7200-A170

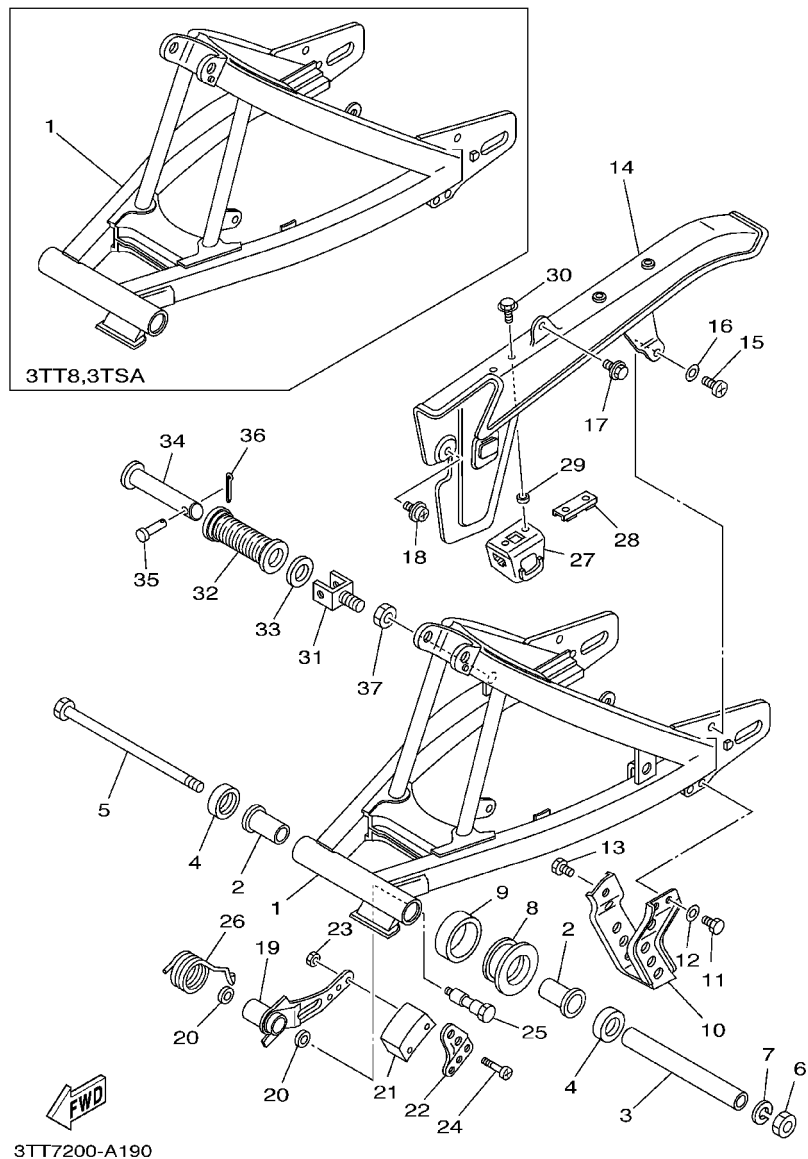
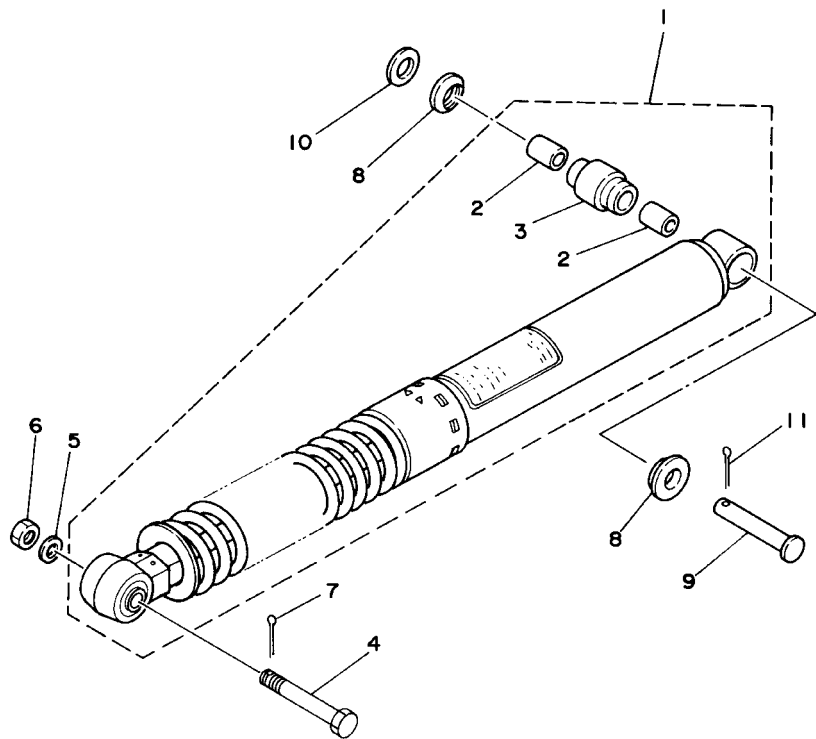

FIG. 19 REAR ARM

BRAZO TRASERO

REF. NO.	PART NO. CODIGO NO.	DESCRIPTION DESCRIPTION	3TT7	3TT8	3TS9	3TSA	REMARKS OBSERVACION
1	18G-22110-00	REAR ARM COMP. BRAZO TRASERO COMPLETO	1		1		
	18G-22110-10	REAR ARM COMP. BRAZO TRASERO COMPLETO		1		1	
2	90386-18028	BUSH BUJE	2	2	2	2	
3	18G-22124-00	BUSH 2 BUJE 2	1	1	1	1	
4	401-22128-01	SEAL, GUARD TAPA DE EMPUJE	2	2	2	2	
5	2N4-22141-00	SHAFT, PIVOT EJE DEL BARCULANTE	1	1	1	1	
6	90185-12046	NUT, SELF-LOCKING TUERCA AUTOBLOCANTE	1	1	1	1	
7	92907-12100	WASHER ARANDELA	1	1	1	1	
8	2A6-22151-00	SEAL, GUARD SELLO DE GUARDA	1	1	1	1	
9	2A6-22152-00	SEAL, GUARD SELLO DE GUARDA	1	1	1	1	
10	2A6-22318-00	GUARD, CHAIN GUARDACADENA	1	1	1	1	
11	97007-06016	BOLT PERNO	2	2	2	2	
12	92907-06600	WASHER, PLATE ARANDELA	2	2	2	2	
13	95807-08012	BOLT, FLANGE TUERCA DE REBORDE	1	1	1	1	
14	4F2-22311-01	CASE, CHAIN CABRECADENA	1	1	1	1	
15	98507-05016	SCREW, PAN HEAD TORNILLO DE CABEZA CON PLANA	1	1	1	1	
16	92907-05600	WASHER, PLATE ARANDELA	1	1	1	1	
17	90119-05059	BOLT, WITH WASHER TORNILLO CON ARANDELA	1	1	1	1	
18	90159-05018	SCREW, WITH WASHER TORNILLO CON VALONA	1	1	1	1	
19	2A6-22179-00	ARM, TENSIONER BRAZO DE TENSOR	1	1	1	1	
20	93109-14021	O-RING RETEN DE ACEITE	2	2	2	2	
21	2N0-22178-00	TENSIONER TENSOR	1	1	1	1	
22	1W1-22187-00	GUIDE, CHAIN GUIA DE CADENA	1	1	1	1	
23	95307-05700	NUT TUERCA	2	2	2	2	
24	98507-05035	SCREW, PAN HEAD TORNILLO DE CABEZA CON PLANA	2	2	2	2	
25	90109-10533	BOLT PERNO	1	1	1	1	
26	90508-35350	SPRING, TORSION RESORTE DE TORSION	1	1	1	1	



3TT3200-4200

FIG. 20 REAR SUSPENSION

SUSPENSION TRASERO

REF. NO.	PART NO. CODIGO NO.	DESCRIPTION DESCRIPTION	3TT7	3TT8	3TS9	3TSA	REMARKS OBSERVACION
1	18G-22210-02	SHOCK ABSORBER ASSY, REAR AMORTIGUADOR TRASERO COMPLETO	1	1	1	1	
2	90380-12051	.BUSH, SOLID .CASQUILLO SOLIDO	2	2	2	2	
3	3R4-22226-00	.BUSH, SHOCK ABSORBER LOWER .BUJE DE AMORTIGUADOR INFERIO	1	1	1	1	
4	90109-10453	BOLT PERNO	1	1	1	1	
5	92901-10200	WASHER, PLAIN ARANDELA PLANA	1			1	
	92907-10200	WASHER, PLAIN ARANDELA		1		1	
6	95302-10700	NUT TUERCA	1			1	
	95307-10700	NUT TUERCA		1		1	
7	91401-20025	PIN, COTTER CHAVETA	1	1	1	1	
8	1W1-22128-00	COVER, THRUST 1 TAPA DE EMPUJE 1	2	2	2	2	
9	90240-12092	PIN, CLEVIS PASADOR CON HOYO	1	1	1	1	
10	92901-12600	WASHER, PLATE ARANDELA PLANA	1			1	
	92907-12600	WASHER ARANDELA		1		1	
11	91401-25020	PIN, COTTER CHAVETA	1	1	1	1	

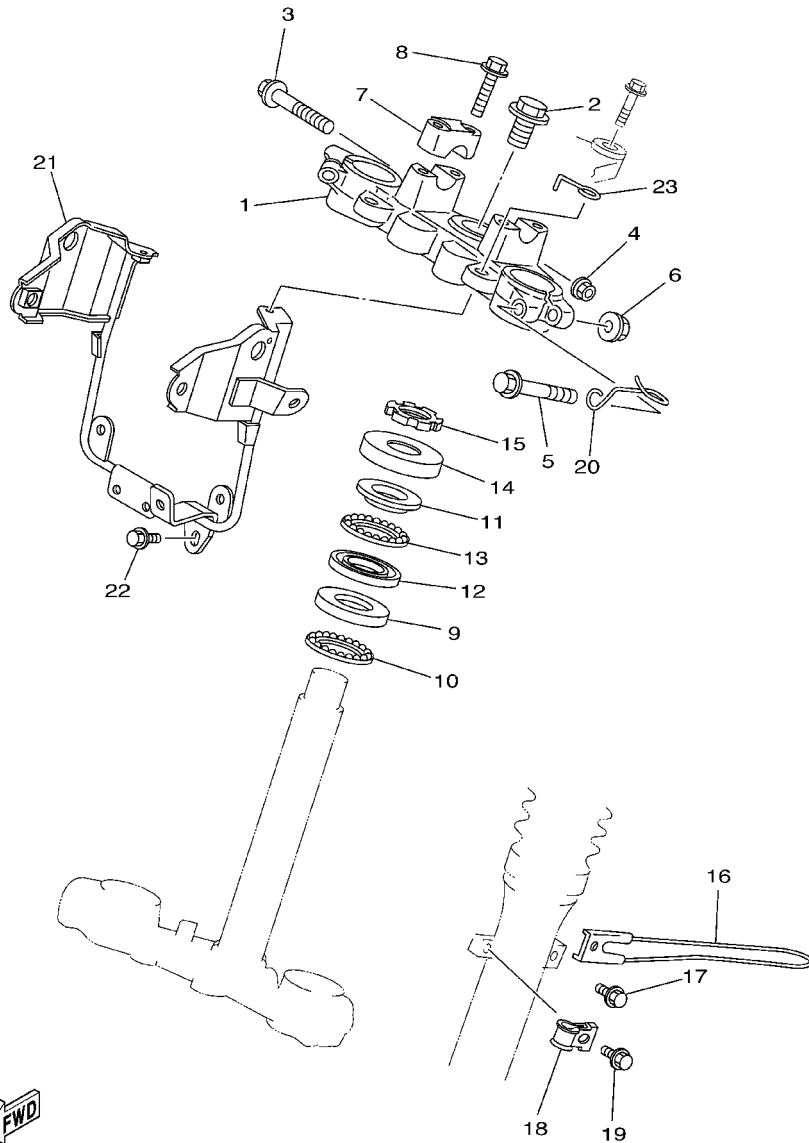

3TT7200-A210

FIG. 21 STEERING

DIRECCION

REF. NO.	PART NO. CODIGO NO.	DESCRIPTION DESCRIPTION	3TT7	3TT8	3TS9	3TSA	REMARKS OBSERVACION
1	18G-23435-00	CROWN, HANDLE PLATINA SUPERIOR	1	1	1		
2	90105-14220	BOLT, FLANGE TORNILLO	1	1	1		
3	95027-08055	BOLT, FLANGE PERNO, DE BRIDA	1	1	1		
4	95707-08500	NUT, FLANGE TUERCA DE BRIDA	1	1	1		
5	95827-10055	BOLT, FLANGE TUERCA DE REBORDE	2	2	2		
6	95707-10500	NUT, FLANGE TUERCA DE BRIDA	2	2	2		
7	1E6-23441-10-98	HOLDER, HANDLE UPPER SOPORTE DE MANUBRIO	2	2	2		LGB
8	95827-08035	BOLT, FLANGE TUERCA DE REBORDE	4	4	4		
9	156-23412-00	RACE, BALL 2 PISTA DE BOLAS 2	1	1	1		
10	156-2341E-00	RETAINER, BALL BEARING BUTTE DE ROULEMENT	1	1	1		
11	22F-23411-01	RACE, BALL 1 PISTA DE BOLAS 1	1	1	1		
12	22F-23412-01	RACE, BALL 2 PISTA DE BOLAS 2	1	1	1		
13	22F-2341E-00	RETAINER, BALL BEARING BUTTE DE ROULEMENT	1	1	1		
14	583-23416-01	COVER, BALL RACE 2 CUBIERTA DE BASE DE BOLA 2	1	1	1		
15	90179-25033	NUT TUERCA	1	1	1		
16	90466-35001	GUIDE GUIA	1	1	1		
17	95807-06010	BOLT, FLANGE TUERCA DE REBORDE	1	1	1		
18	3Y1-23319-00	HOLDER, CABLE 2 SOSTEN DE CABLE 2	1	1	1		
19	95807-06012	BOLT, FLANGE TUERCA DE REBORDE	1	1	1		
20	18G-23389-00	GUIDE, CABLE GUIA DE CABLE	1	1	1		
21	18G-23174-00	STAY, HEADLIGHT SOPORTE DEL FARO DELANTERO	1	1	1		
22	95807-06010	BOLT, FLANGE TUERCA DE REBORDE	1	1	1		
23	18G-2331E-00	GUIDE, CABLE GUIA DE CABLE	1	1	1		

FIG. 22 STEERING 2

DIRECCION 2

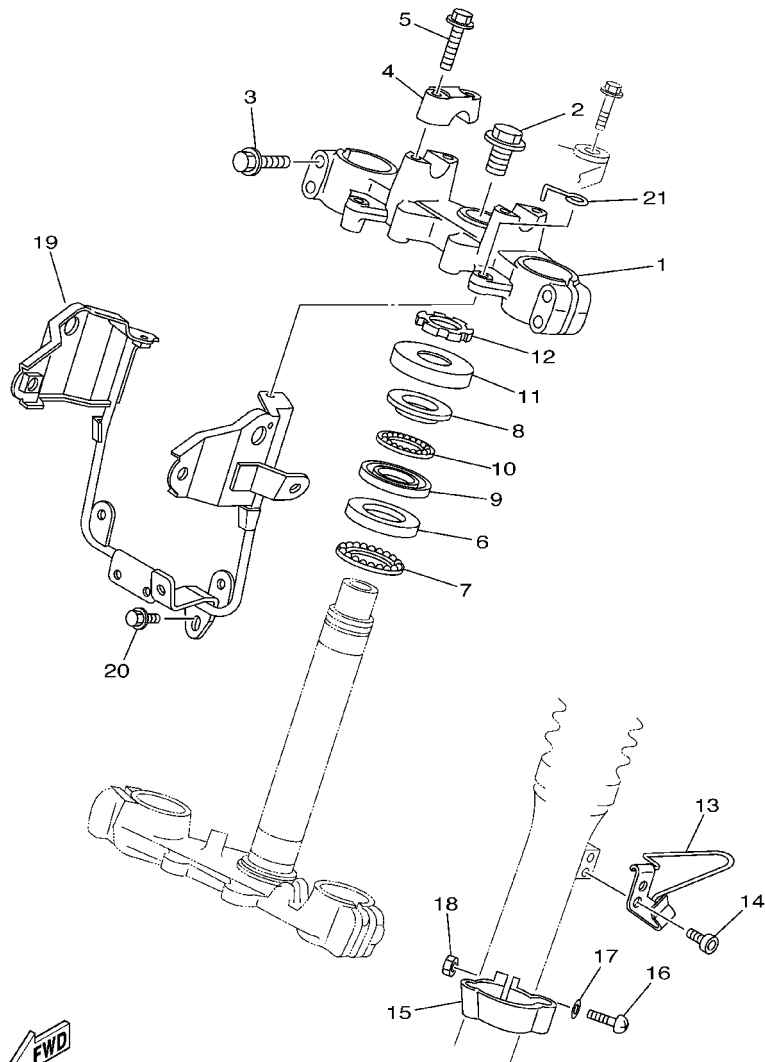

3FJE700-A210

REF. NO.	PART NO. CODIGO NO.	DESCRIPTION DESCRIPTION	3TT7	3TT8	3TS9	3TSA	REMARKS OBSERVACION
1	3TS-23435-00	CROWN, HANDLE PLATINA SUPERIOR				1	
2	90105-14220	BOLT, FLANGE TORNILLO				1	
3	95027-08040	BOLT, FLANGE PERNO, DE BRIDA				4	
4	1E6-23441-10-98	HOLDER, HANDLE UPPER SOPORTE DE MANUBRIO				2	LGB
5	95827-08035	BOLT, FLANGE TUERCA DE REBORDE				4	
6	156-23412-00	RACE, BALL 2 PISTA DE BOLAS 2				1	
7	156-2341E-00	RETAINER, BALL BEARING BUTTE DE ROULEMENT				1	
8	22F-23411-01	RACE, BALL 1 PISTA DE BOLAS 1				1	
9	22F-23412-01	RACE, BALL 2 PISTA DE BOLAS 2				1	
10	22F-2341E-00	RETAINER, BALL BEARING BUTTE DE ROULEMENT				1	
11	583-23416-01	COVER, BALL RACE 2 CUBIERTA DE BASE DE BOLA 2				1	
12	90179-25033	NUT TUERCA				1	
13	34X-25876-00	HOLDER, BRAKE HOSE 2 SOPORTE DE MANGUERA FRENO 2				1	
14	91317-06010	BOLT PERNO				2	
15	34X-23317-00	HOLDER, CABLE SOSTEN DE CABLE				1	
16	98507-05018	SCREW, PAN HEAD TORNILLO DE CABEZA CON PLANA				1	
17	92907-05600	WASHER, PLATE ARANDELA				1	
18	95307-05600	NUT TUERCA				1	
19	18G-23174-10	STAY, HEADLIGHT SOPORTE DEL FARO DELANTERO				1	
20	95807-06010	BOLT, FLANGE TUERCA DE REBORDE				1	
21	18G-2331E-00	GUIDE, CABLE GUIA DE CABLE				1	

FIG. 23 FRONT FORK

HORQUILLA DELANTERA

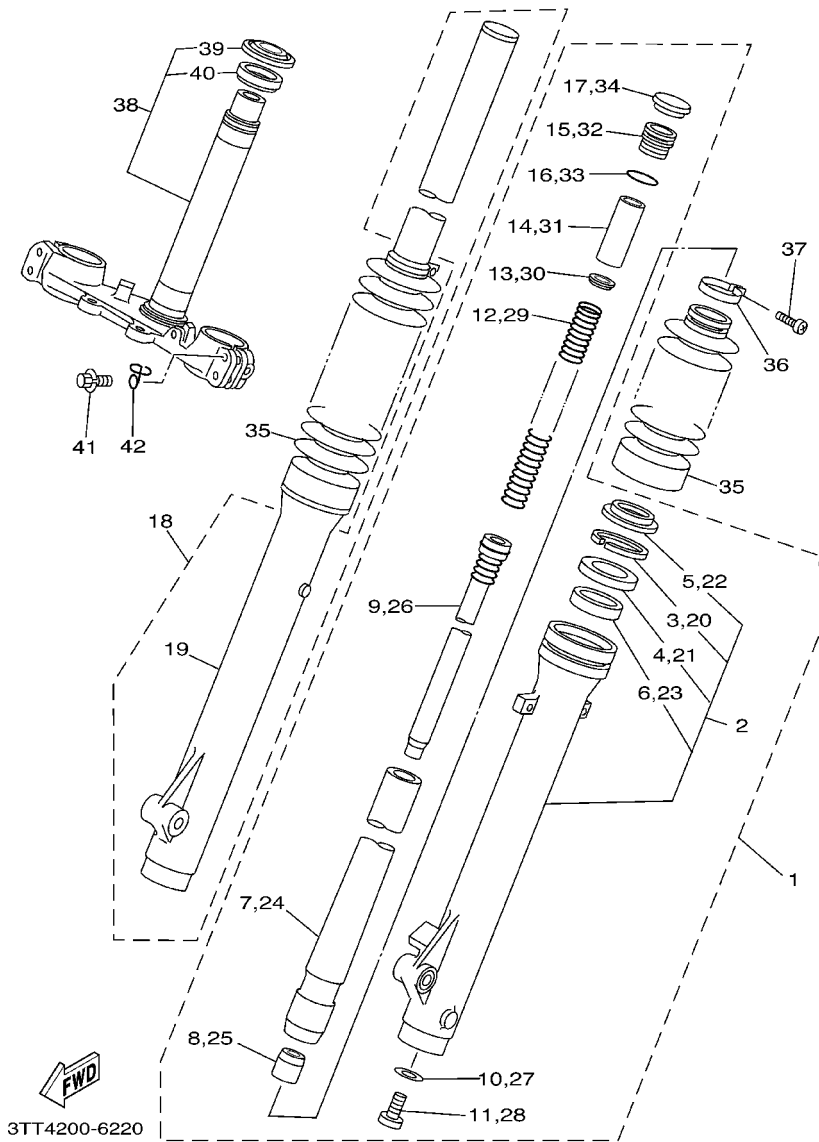

REF. NO.	PART NO. CODIGO NO.	DESCRIPTION DESCRIPTION	3TT7	3TT8	3TS9	3TSA	REMARKS OBSERVACION
1	18G-23102-00	FRONT FORK ASSY (L.H) HORQUILLA DELANTERA COMPL.(MI)	1	1	1		
2	3TT-23106-20	.OUTER TUBE COMP. (L.H) .TUBO EXTERIOR COMPLETO (MI)	1	1	1		
3	4A1-23156-00	..CLIP, OIL SEAL ..PRESILLA DEL RETEN DE ACEITE	1	1	1		
4	1T3-23145-00	..OIL SEAL ..RETEN DE ACEITE	1	1	1		
5	3R2-23144-00	..SEAL, DUST ..GUARDAPOLVO	1	1	1		
6	1H3-23125-00	..METAL, SLIDE 1 ..METAL CORREDIZO 1	1	1	1		
7	18G-23110-00	.INNER TUBE COMP.1 .TUBO INTERIOR COMPLETO 1	1	1	1		
8	1W1-23173-L0	.SPINDLE, TAPER .VASTAGO AHUSADO	1	1	1		
9	18G-23170-00	.CYLINDER COMP., FRONT FORK .CILINDRO COMPL. DE HORQ DELAN	1	1	1		
10	509-23158-L0	.GASKET .EMPAQUE	1	1	1		
11	278-23181-50	.BOLT, HEXAGON SOCKET HEAD .TORNILLO CABEZAHEXAGONAL	1	1	1		
12	18G-23141-00	.SPRING, FRONT FORK .RESORTE HORQUILLA DELANT.	1	1	1		
13	3DM-23149-10	.WASHER, SPRING UPPER .ARANDELA DE RESORTE SUPERIOR	1	1	1		
14	5N8-23118-00	.SPACER .SEPARADOR	1	1	1		
15	1U6-23111-M1	.BOLT, CAP .TAPON	1	1	1		
16	240-23114-00	.GASKET .EMPAQUE	1	1	1		
17	1U6-23168-M0	.CAP, FRONT FORK .TAPA DE HORQUILLA DELANTERA	1	1	1		
18	18G-23103-00	FRONT FORK ASSY (R.H) HORQUILLA DELANTERA COMPL.(MD)	1	1	1		
19	3TT-23107-20	.OUTER TUBE COMP. (R.H) .TUBO EXTERIOR COMPLETO (MD)	1	1	1		
20	4A1-23156-00	..CLIP, OIL SEAL ..PRESILLA DEL RETEN DE ACEITE	1	1	1		
21	1T3-23145-00	..OIL SEAL ..RETEN DE ACEITE	1	1	1		
22	3R2-23144-00	..SEAL, DUST ..GUARDAPOLVO	1	1	1		
23	1H3-23125-00	..METAL, SLIDE 1 ..METAL CORREDIZO 1	1	1	1		
24	18G-23110-00	.INNER TUBE COMP.1 .TUBO INTERIOR COMPLETO 1	1	1	1		
25	1W1-23173-L0	.SPINDLE, TAPER .VASTAGO AHUSADO	1	1	1		
26	18G-23170-00	.CYLINDER COMP., FRONT FORK .CILINDRO COMPL. DE HORQ DELAN	1	1	1		
27	509-23158-L0	.GASKET .EMPAQUE	1	1	1		

FIG. 23 FRONT FORK

HORQUILLA DELANTERA

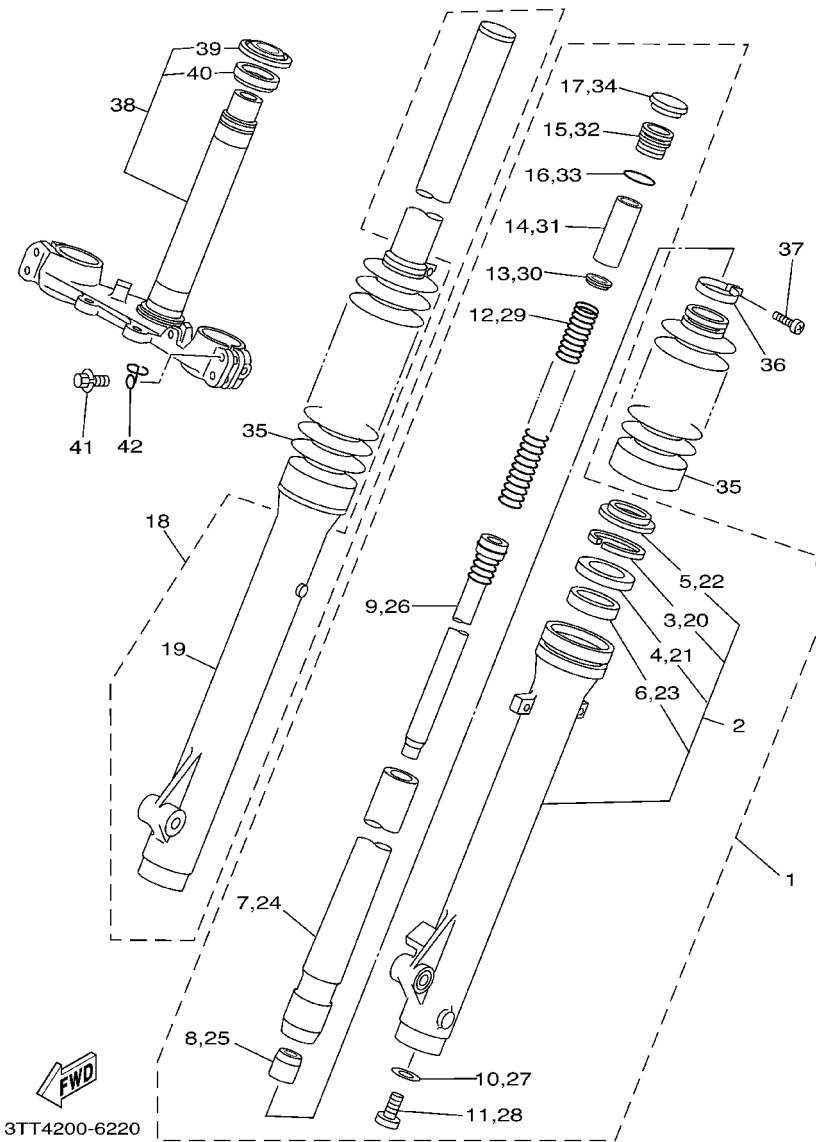

REF. NO.	PART NO. CODIGO NO.	DESCRIPTION DESCRIPTION	3TT7	3TT8	3TS9	3TSA	REMARKS OBSERVACION
28	278-23181-50	.BOLT, HEXAGON SOCKET HEAD .TORNILLO CABEZAHEXAGONAL	1	1	1		
29	18G-23141-00	.SPRING, FRONT FORK .RESORTE HORQUILLA DELANT.	1	1	1		
30	3DM-23149-10	.WASHER, SPRING UPPER .ARANDELA DE RESORTE SUPERIOR	1	1	1		
31	5N8-23118-00	.SPACER .SEPARADOR	1	1	1		
32	1U6-23111-M1	.BOLT, CAP .TAPON	1	1	1		
33	240-23114-00	.GASKET .EMPAQUE	1	1	1		
34	1U6-23168-M0	.CAP, FRONT FORK .TAPA DE HORQUILLA DELANTERA	1	1	1		
35	18G-23191-00	BOOT FUNDA	2	2	2		
36	18G-23192-00	BAND BANDA	2	2	2		
37	509-23194-L0	SCREW, BOOT BAND TORNILLO DE BANDA DE FUNDA	2	2	2		
38	18G-23340-00	UNDER BRACKET COMP. PLATINA INFERIOR COMPLETA	1	1	1		
39	164-23462-00	.SEAL, STEERING .RETEN DE DIRECCION	1	1	1		
40	156-23411-00	.RACE, BALL 1 .PISTA DE BOLAS 1	1	1	1		
41	3TS-23346-00	BOLT 1 PERNO 1	4	4	4		
42	18G-23317-00	HOLDER, CABLE SOSTEN DE CABLE	1	1	1		

FIG. 24 FRONT FORK 2

HORQUILLA DELANTERA 2

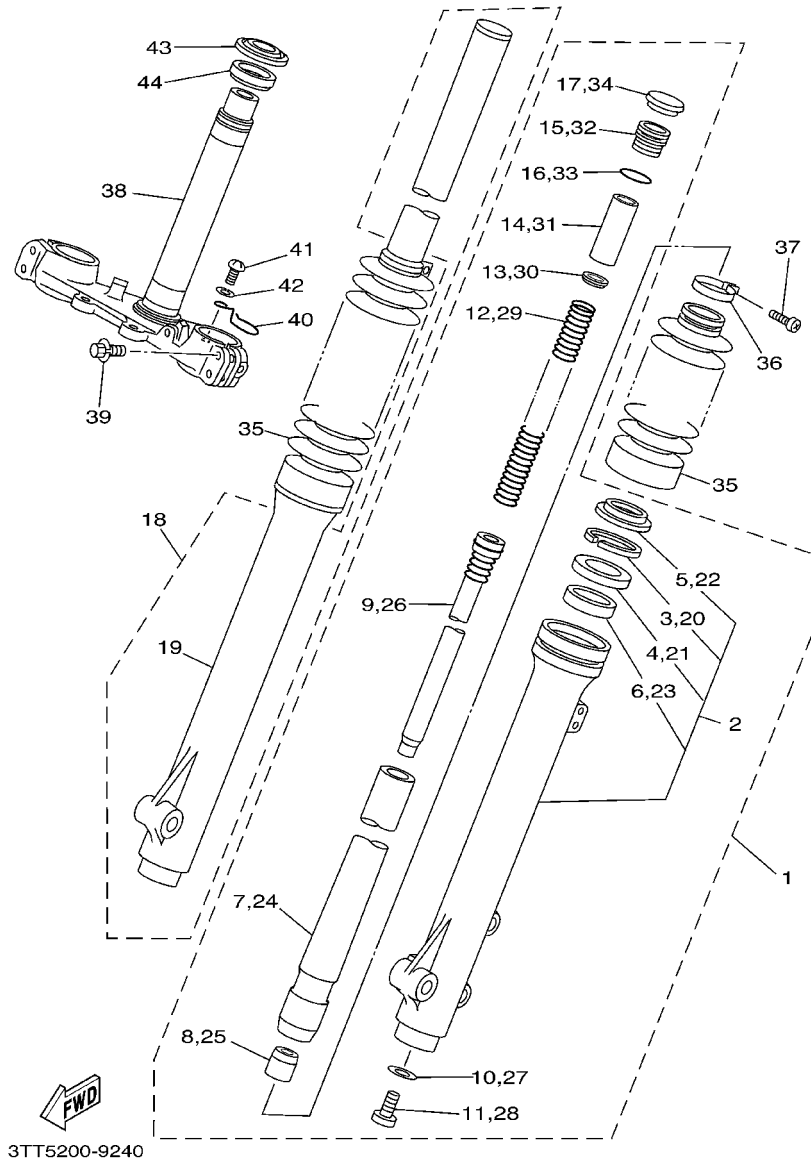

3TT5200-9240

REF. NO.	PART NO. CODIGO NO.	DESCRIPTION DESCRIPTION	3TT7	3TT8	3TS9	3TSA	REMARKS OBSERVACION
1	3TS-23102-00	FRONT FORK ASSY (L.H) HORQUILLA DELANTERA COMPL. (MI)				1	
2	3TS-23106-00	.OUTER TUBE COMP. (L.H) .TUBO EXTERIOR COMPLETO (MI)				1	
3	4A1-23156-00	.CLIP, OIL SEAL .PRESILLA DEL RETEN DE ACEITE				1	
4	1T3-23145-00	.OIL SEAL .RETEN DE ACEITE				1	
5	3R2-23144-00	.SEAL, DUST .GUARDAPOLVO				1	
6	1H3-23125-00	.METAL, SLIDE 1 .METAL CORREDIZO 1				1	
7	18G-23110-00	.INNER TUBE COMP.1 .TUBO INTERIOR COMPLETO 1				1	
8	1W1-23173-L0	.SPINDLE, TAPER .VASTAGO AHUSADO				1	
9	18G-23170-00	.CYLINDER COMP., FRONT FORK .CILINDRO COMPL. DE HORQ DELAN				1	
10	509-23158-L0	.GASKET .EMPAQUE				1	
11	278-23181-50	.BOLT, HEXAGON SOCKET HEAD .TORNILLO CABEZAHEXAGONAL				1	
12	18G-23141-00	.SPRING, FRONT FORK .RESORTE HORQUILLA DELANT.				1	
13	3DM-23149-10	.WASHER, SPRING UPPER .ARANDELA DE RESORTE SUPERIOR				1	
14	5N8-23118-00	.SPACER .SEPARADOR				1	
15	1U6-23111-M1	.BOLT, CAP .TAPON				1	
16	240-23114-00	.GASKET .EMPAQUE				1	
17	1U6-23168-M0	.CAP, FRONT FORK .TAPA DE HORQUILLA DELANTERA				1	
18	3TS-23103-00	FRONT FORK ASSY (R.H) HORQUILLA DELANTERA COMPL. (MD)				1	
19	3TS-23107-00	.OUTER TUBE COMP. (R.H) .TUBO EXTERIOR COMPLETO (MD)				1	
20	4A1-23156-00	.CLIP, OIL SEAL .PRESILLA DEL RETEN DE ACEITE				1	
21	1T3-23145-00	.OIL SEAL .RETEN DE ACEITE				1	
22	3R2-23144-00	.SEAL, DUST .GUARDAPOLVO				1	
23	1H3-23125-00	.METAL, SLIDE 1 .METAL CORREDIZO 1				1	
24	18G-23110-00	.INNER TUBE COMP.1 .TUBO INTERIOR COMPLETO 1				1	
25	1W1-23173-L0	.SPINDLE, TAPER .VASTAGO AHUSADO				1	
26	18G-23170-00	.CYLINDER COMP., FRONT FORK .CILINDRO COMPL. DE HORQ DELAN				1	
27	509-23158-L0	.GASKET .EMPAQUE				1	

FIG. 24 FRONT FORK 2

HORQUILLA DELANTERA 2

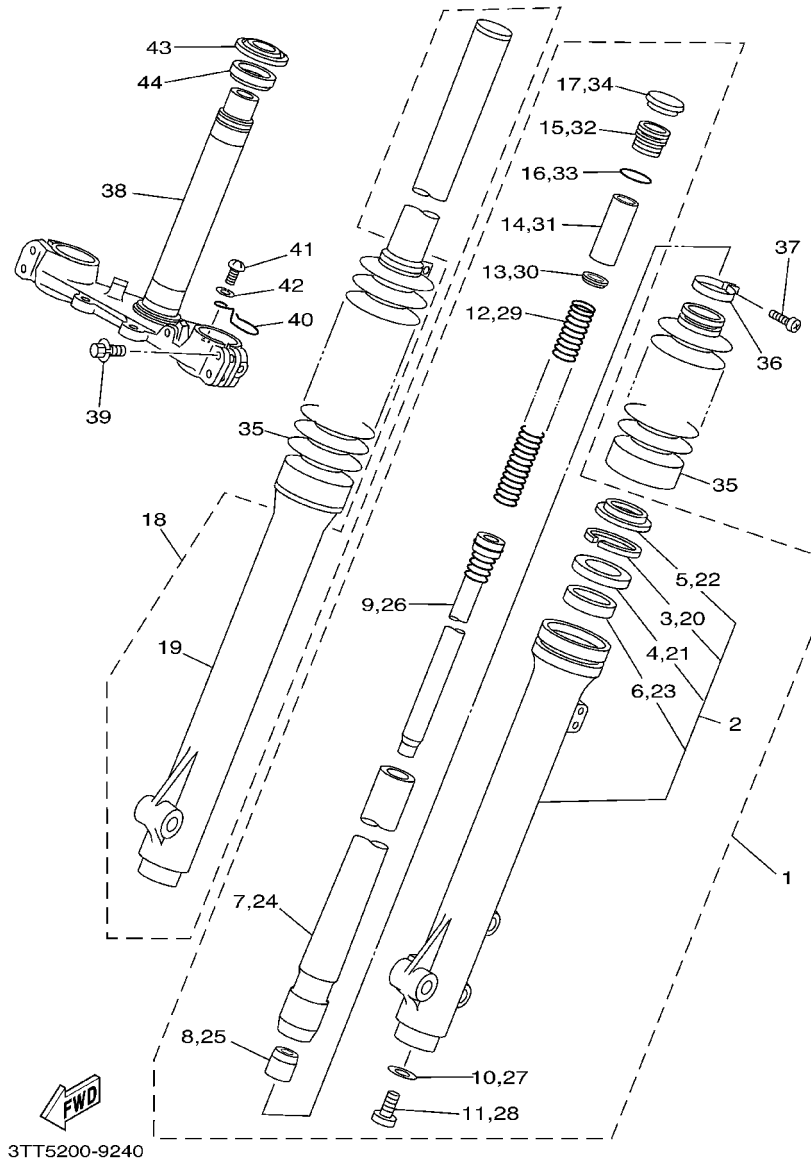

REF. NO.	PART NO. CODIGO NO.	DESCRIPTION DESCRIPTION	3TT7	3TT8	3TS9	3TSA	REMARKS OBSERVACION
28	278-23181-50	.BOLT, HEXAGON SOCKET HEAD .TORNILLO CABEZAHEXAGONAL				1	
29	18G-23141-00	.SPRING, FRONT FORK .RESORTE HORQUILLA DELANT.				1	
30	3DM-23149-10	.WASHER, SPRING UPPER .ARANDELA DE RESORTE SUPERIOR				1	
31	5N8-23118-00	.SPACER .SEPARADOR				1	
32	1U6-23111-M1	.BOLT, CAP .TAPON				1	
33	240-23114-00	.GASKET .EMPAQUE				1	
34	1U6-23168-M0	.CAP, FRONT FORK .TAPA DE HORQUILLA DELANTERA				1	
35	18G-23191-00	BOOT FUNDA				2	
36	18G-23192-00	BAND BANDA				2	
37	509-23194-L0	SCREW, BOOT BAND TORNILLO DE BANDA DE FUNDA				2	
38	3TS-23340-00	UNDER BRACKET COMP. PLATINA INFERIOR COMPLETA				1	
39	3TS-23346-00	BOLT 1 PERNO 1				4	
40	10V-2331E-02	GUIDE, CABLE GUIA DE CABLE				1	
41	98501-06012	SCREW, PAN HEAD TORNILLO DE CABEZA CRUZADA				1	
42	92901-06100	WASHER, SPRING ARANDELA PLANA				1	
43	156-23411-00	RACE, BALL 1 PISTA DE BOLAS 1				1	
44	164-23462-00	SEAL, STEERING RETEN DE DIRECCION				1	

FIG. 25 FUEL TANK

DEPOSITO DE COMBUSTIBLE

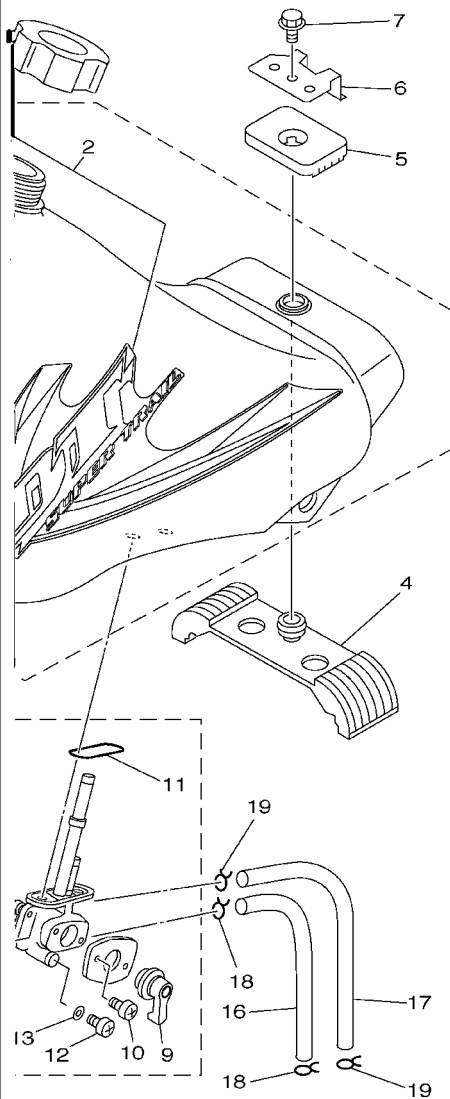

REF. NO.	PART NO. CODIGO NO.	DESCRIPTION DESCRIPTION	3TT7	3TT8	3TS9	3TSA	REMARKS OBSERVACION
1	18G-Y2410-00-01	FUEL TANK COMP. DEPOSITO DE COMBUSTIBLE COMP.	1		1		UR BWC1
	18G-Y2410-00-02	FUEL TANK COMP. DEPOSITO DE COMBUSTIBLE COMP.	1		1		UR VRC7
	18G-Y2410-00-03	FUEL TANK COMP. DEPOSITO DE COMBUSTIBLE COMP.	1		1		UR CM3
	18G-Y2410-00-04	FUEL TANK COMP. DEPOSITO DE COMBUSTIBLE COMP.	1		1		UR DPBMC
	18G-Y2410-20-04	FUEL TANK COMP. DEPOSITO DE COMBUSTIBLE COMP.		1		1	UR BWC1
	18G-Y2410-20-05	FUEL TANK COMP. DEPOSITO DE COMBUSTIBLE COMP.		1		1	UR VRC7
	18G-Y2410-20-07	FUEL TANK COMP. DEPOSITO DE COMBUSTIBLE COMP.		1		1	UR CM3
	18G-Y2410-20-06	FUEL TANK COMP. DEPOSITO DE COMBUSTIBLE COMP.		1		1	UR DPBMC
2	3TT-24240-60	.GRAPHIC SET .JUEGO DE CALCOMANIAS	1	1	1	1	UR FOR BWC1
	3TT-24240-70	.GRAPHIC SET .JUEGO DE CALCOMANIAS	1	1	1	1	UR FOR VRC7
	3TT-24240-80	.GRAPHIC SET .JUEGO DE CALCOMANIAS	1	1	1	1	UR FOR CM3
	3TT-24240-90	.GRAPHIC SET .JUEGO DE CALCOMANIAS	1	1	1	1	UR FOR DPBMC
3	278-24181-00	DAMPER, LOCATING 1 AMORTIGUADOR DE MONTAJE 1	2	2	2	2	
4	18G-24182-00	DAMPER, LOCATING 2 AMORTIGUADOR DE MONTAJE 2	1	1	1	1	
5	18G-24183-01	DAMPER, LOCATING 3 AMORTIGUADOR DE MONTAJE 3	1	1	1	1	
6	18G-24186-01	WASHER, SPECIAL ARANDELA ESPECIAL	1	1	1	1	
7	95807-06010	BOLT, FLANGE TUERCA DE REBORDE	1	1	1	1	
8	18G-24500-02	FUEL COCK ASSY 1 GRIFO DE COMBUSTIBLE 1	1	1	1	1	
9	3H3-W0092-00	.FUEL COCK VALVE SET .JUEGO DE VALVULAS DE GRIFO	1	1	1	1	
10	98501-03008	.SCREW, PAN HEAD .TORNILLO DE CABEZA CRUZADA	2	2	2	2	
11	2W6-24512-00	.O-RING EMPAQUE	1	1	1	1	
12	92502-06008	.SCREW, PAN HEAD .TORNILLO CABEZA CRUZADA	1	1	1	1	
13	2G2-24522-00	.GASKET .EMPAQUE	1	1	1	1	
14	90149-06011	SCREW TORNILLO DE REGLAJE	2	2	2	2	
15	90202-05193	WASHER, PLATE ARANDELA DE PLANA	2	2	2	2	
16	90445-104H8	HOSE (L185) TUBO (L185)	1	1	1	1	
17	90445-07176	HOSE (L200) TUBO (L200)	1		1		

FIG. 26 SEAT

ASIENTO

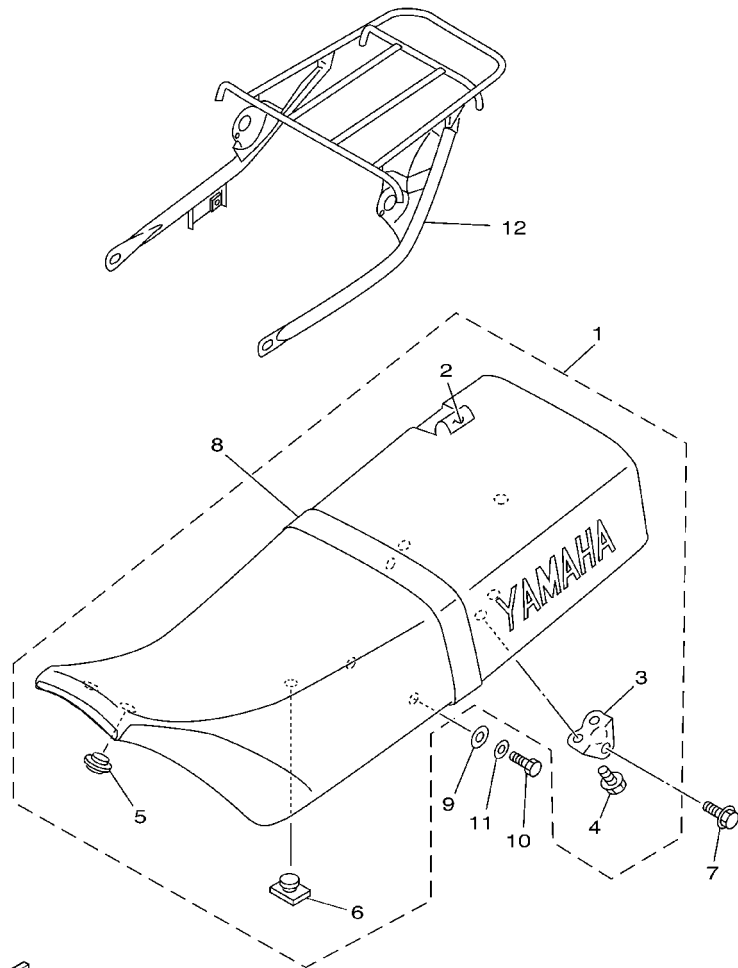

3TT4200-6240

REF. NO.	PART NO. CODIGO NO.	DESCRIPTION DESCRIPTION	3TT7	3TT8	3TS9	3TSA	REMARKS OBSERVACION
1	18G-24770-B0	SEMI-DOUBLE SEAT ASSY ASIENTO SEMI-DOBLE COMPLETO	1	1	1	1	UR BWC1,VRC7
	18G-24770-12	SEMI-DOUBLE SEAT ASSY ASIENTO SEMI-DOBLE COMPLETO	1	1	1	1	UR CM3
	18G-24770-91	SEMI-DOUBLE SEAT ASSY ASIENTO SEMI-DOBLE COMPLETO	1	1	1	1	UR DPBMC
2	18G-24731-B0	.COVER, SEAT .FUNDA DE SILLIN	1	1	1	1	UR BWC1,VRC7
	18G-24731-12	.COVER, SEAT .FUNDA DE SILLIN	1	1	1	1	UR CM3
	18G-24731-91	.COVER, SEAT .FUNDA DE SILLIN	1	1	1	1	UR DPBMC
3	18G-24738-00	.BRACKET, SEAT .SOPORTE DE ASIENTO	2	2	2	2	
4	95807-06012	.BOLT, FLANGE .TUERCA DE REBORDE	4	4	4	4	
5	18A-24723-00	.DAMPER, SEAT .AMORTIGUADOR DE ASIENTO	1	1	1	1	
6	509-24724-00	.DAMPER, SEAT .AMORTIGUADOR DE ASIENTO	2	2	2	2	
7	95807-08045	BOLT, FLANGE TUERCA DE REBORDE	2	2	2	2	
8	18G-24734-B0	BAND, SEAT BANDA DE ASIENTO	1	1	1	1	UR BWC1,VRC7
	18G-24734-10	BAND, SEAT BANDA DE ASIENTO	1	1	1	1	UR CM3
	18G-24734-90	BAND, SEAT BANDA DE ASIENTO	1	1	1	1	UR DPBMC
9	92907-08200	WASHER ARANDELA	2	2	2	2	
10	97007-08020	BOLT PERNO	2		2		
	97007-08016	BOLT PERNO		2		2	
11	92907-08600	WASHER, PLATE ARANDELA	2	2	2	2	
12	3TT-24830-00	SUB CARRIER ASSY SUBPORTADOR COMPLETO	1	1	1	1	

FIG. 27 FRONT WHEEL

RUEDA DELANTERA

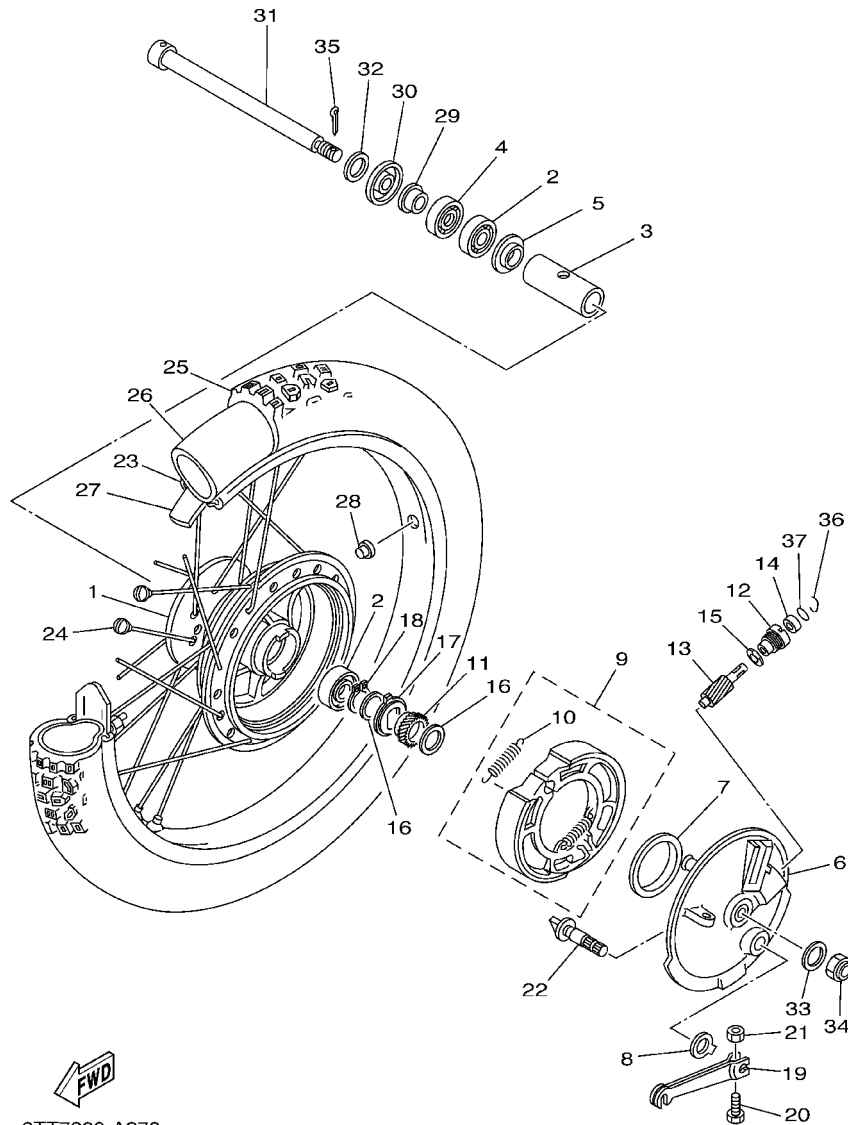

FWD
3TT7200-A270

REF. NO.	PART NO. CODIGO NO.	DESCRIPTION DESCRIPTION	3TT7	3TT8	3TS9	3TSA	REMARKS OBSERVACION
1	2A6-25111-00-35	HUB, FRONT MASA DELANTERA	1	1	1		SL
2	93306-30101	BEARING (B6301) COJINETE (B6301)	2	2	2		
3	90560-12138	SPACER SEPARADOR	1	1	1		
4	93102-18008	OIL SEAL RETEN DE ACEITE	1	1	1		
5	109-25315-00	FLANGE, SPACER SEPARADOR	1	1	1		
6	3TL-25121-00-35	PLATE, BRAKE SHOE PLACA DE ZAPATA DE FRENO	1	1	1		SL
7	93105-47007	OIL SEAL RETEN DE ACEITE	1	1	1		
8	3Y6-2533A-01	PLATE, INDICATOR PLACA INDICADOR	1	1	1		
9	3KG-W253E-00	BRAKE SHOE KIT JUEGO DE ZAPATA DE FRENO	1	1	1		
10	90506-15260	SPRING, TENSION RESORTE DE TENSION	2	2	2		
11	5J0-25135-00	GEAR, DRIVE ENGRANAJE DE TRACCION	1	1	1		
12	109-25136-00	BUSH BUJE	1	1	1		
13	5J0-25138-00	GEAR, METER ENGRANAJE DE MEDIDOR	1	1	1		
14	93104-07003	OIL SEAL SELLO ACEITE	1	1	1		
15	90201-07076	WASHER, PLATE ARANDELA PLANA	1	1	1		
16	90201-20269	WASHER, PLATE ARANDELA PLANA	2	2	2		
17	183-25149-00	CLUTCH, METER EMBRAGUE DEL CUENTAKMS	1	1	1		
18	99009-20400	CIRCLIP PRESILLA REDONDA	1	1	1		
19	2N4-25155-00	LEVER, CAMSHAFT 1 PALANCA DE ARBOL DE LEVAS 1	1	1	1		
20	90101-06278	BOLT TORNILLO	1	1	1		
21	95301-06600	NUT TUERCA HEXAGONAL	1	1	1		
22	248-25351-10	CAMSHAFT ARBOL DE LEVAS	1	1	1		
23	94416-21006	RIM (1.60-21) ARO (1.60-21)	1	1	1		
24	2A6-25104-01	SPOKE SET, FRONT JUEGO DE RAYOS DELANTERO	1	1	1		
25	94127-21779	TIRE (MCS 2.75-21 4PR) NEUMATICO (MCS 2.75-21 4PR)	1	1	1		UR BRIDGESTONE
	94127-210A1	TIRE (2.75-21) NEUMATICO (2.75-21)	1	1	1		UR YOKOHAMA
26	94227-21123	TUBE (2.75-21) TUBO (2.75-21)	1	1	1		UR BRIDGESTONE

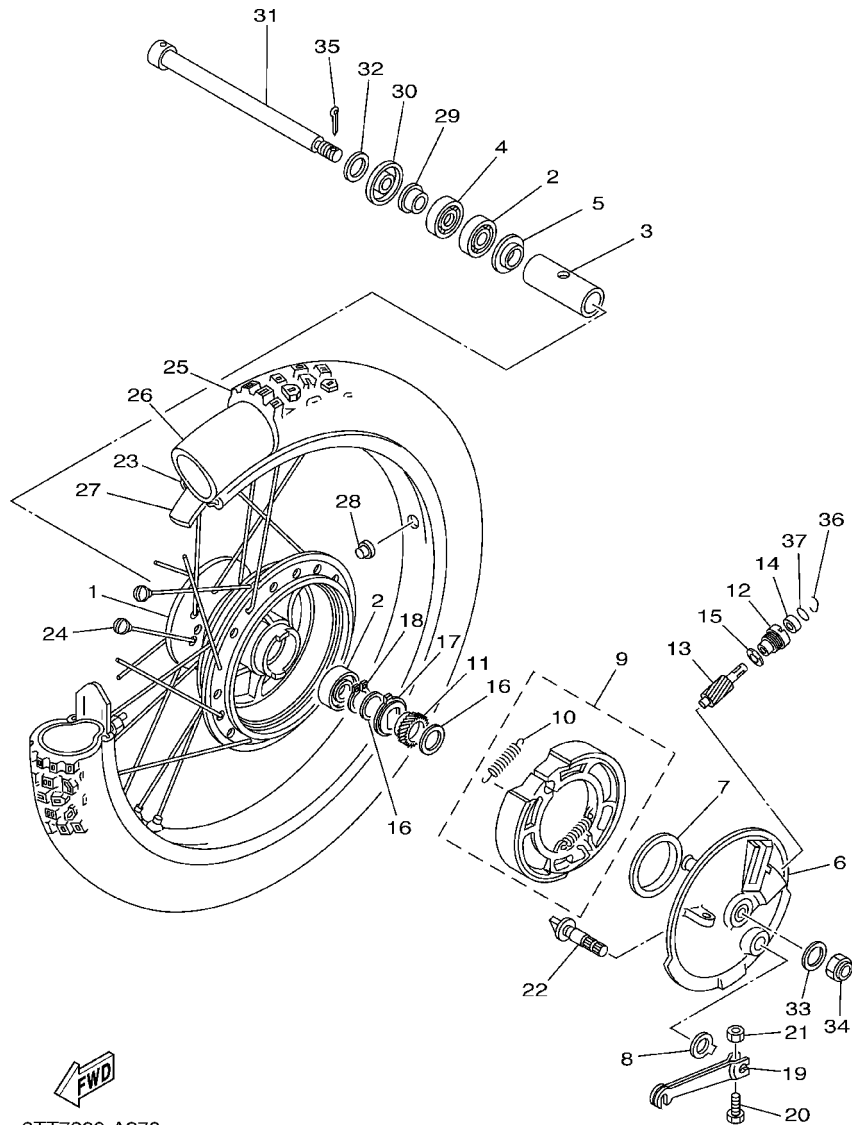

3TT7200-A270

FIG. 27 FRONT WHEEL

RUEDA DELANTERA

REF. NO.	PART NO. CODIGO NO.	DESCRIPTION DESCRIPTION	3TT7	3TT8	3TS9	3TSA	REMARKS OBSERVACION
26	94225-21186	TUBE (2.50-21) TUBO (2.50-21)	1	1	1		UR YOKOHAMA
27	94330-21084	BAND, RIM (3.00-21) BANDA DE ARO (3.00-21)	1	1	1		UR BRIDGESTONE
	94325-21117	BAND, RIM (3.00-21) BANDA DE ARO (3.00-21)	1	1	1		UR YOKOHAMA
28	90338-09130	PLUG TAPON	1	1	1		
29	90387-12265	COLLAR COLLAR	1	1	1		
30	2K5-25118-00	COVER, HUB DUST CUBIERTA DE MASA PARA POLVO	1	1	1		
31	353-25381-00	AXLE, WHEEL EJE DE RUEDA	1	1	1		
32	90201-12749	WASHER, PLATE ARANDELA PLANA	1	1	1		
33	92901-10200	WASHER, PLAIN ARANDELA PLANA	1	1	1		
34	90171-10004	NUT, CASTLE TUERCA ENTALLADA	1	1	1		
35	91401-20020	PIN, COTTER CHAVETA	1	1	1		
36	102-25137-00	RING, STOP ANILLO DE TOPE	1	1	1		
37	93210-14104	O-RING JUNTA TORICA	1	1	1		

FIG. 28 FRONT WHEEL 2

RUEDA DELANTERA 2

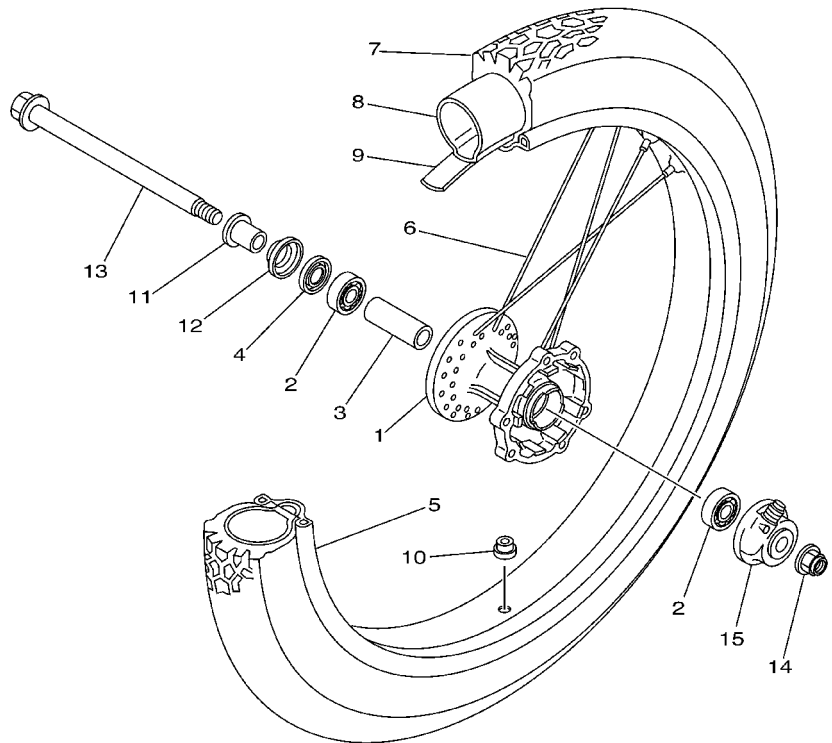

REF. NO.	PART NO. CODIGO NO.	DESCRIPTION DESCRIPTION	3TT7	3TT8	3TS9	3TSA	REMARKS OBSERVACION
1	34X-25111-02-35	HUB, FRONT MASA DELANTERA				1	SL
2	93306-20205	BEARING (B6202) COJINETE (B6202)				2	
3	90560-15290	SPACER SEPARADOR				1	
4	93102-20281	OIL SEAL (SD 20-35-5) SELLO ACEITE (SD 20-35-5)				1	
5	94416-21007	RIM (1.60-21) ARO (1.60-21)				1	
6	34Y-25104-00	SPOKE SET, FRONT JUEGO DE RAYOS DELANTERO				1	
7	94127-21779	TIRE (MCS 2.75-21 4PR) NEUMATICO (MCS 2.75-21 4PR)				1	UR BRIDGESTONE
	94127-210A1	TIRE (2.75-21) NEUMATICO (2.75-21)				1	UR YOKOHAMA
8	94227-21123	TUBE (2.75-21) TUBO (2.75-21)				1	UR BRIDGESTONE
	94225-21186	TUBE (2.50-21) TUBO (2.50-21)				1	UR YOKOHAMA
9	94330-21084	BAND, RIM (3.00-21) BANDA DE ARO (3.00-21)				1	UR BRIDGESTONE
	94325-21117	BAND, RIM (2.50-21) BANDA DE ARO (2.50-21)				1	UR YOKOHAMA
10	90338-09130	PLUG TAPON				1	
11	90387-15600	COLLAR COLLAR				1	
12	322-25118-00	COVER, HUB DUST CUBIERTA DE MASA PARA POLVO				1	
13	33M-25181-00	AXLE, WHEEL EJE DE LA RUEDA				1	
14	95604-14200	NUT, SELF-LOCKING TUERCA DE AUTO-CIERRE				1	
15	34X-25190-01	GEAR UNIT ASSY UNIDAD DE ENGRANAJE COMPLETA				1	



3TT5200-9280

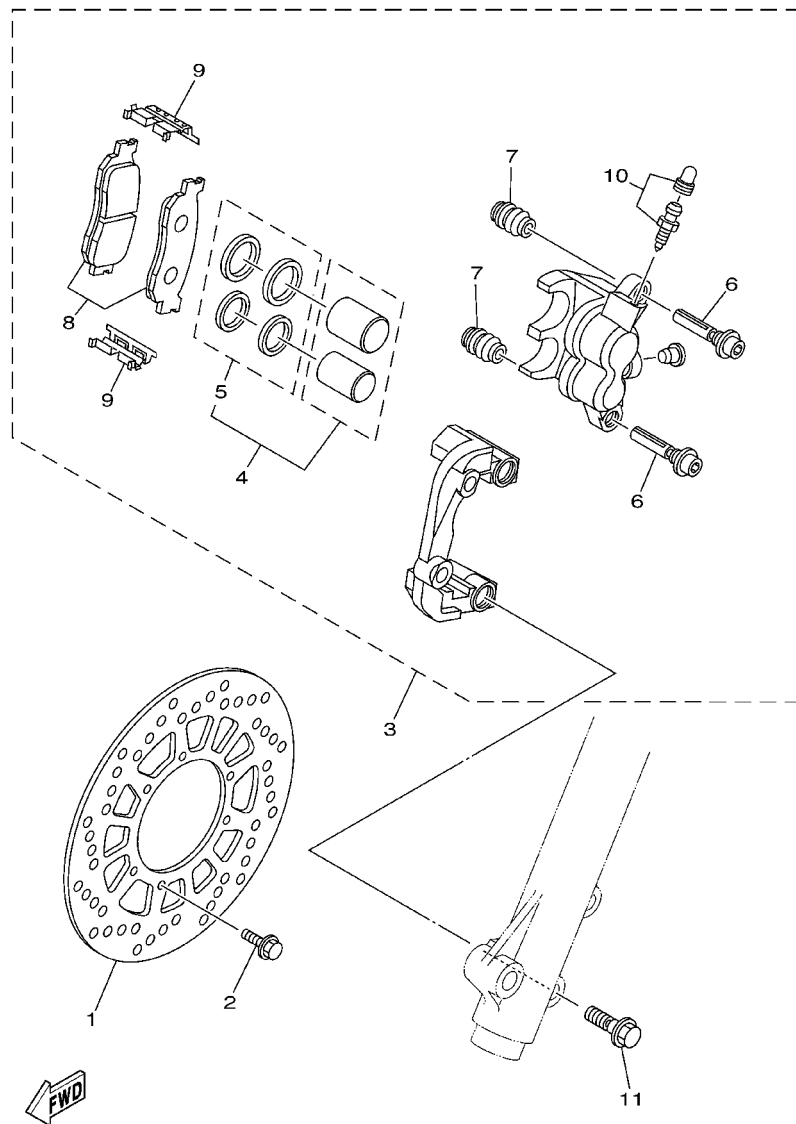

3TT5200-9290

FIG. 29 FRONT BRAKE CALIPER CALIBRE FRENO DELANTERA

REF. NO.	PART NO. CODIGO NO.	DESCRIPTION DESCRIPTION	3TT7	3TT8	3TS9	3TSA	REMARKS OBSERVACION
1	4JG-2582T-10	DISC, BRAKE DISCO DE FRENO (IZQUIERDO)				1	
2	90109-065G4	BOLT PERNO				6	
3	4JG-2580T-00	CALIPER ASSY (LEFT) CALIBRE COMPLETO (IZQUIERDO)				1	
4	4JG-W0057-00	.PISTON ASSY, CALIPER .PISTON COMPLETO PINZA				1	
5	4JG-W0047-00	..CALIPER SEAL KIT ..JUEGO DE RETENES DE PINZA				1	
6	5JW-25914-00	.PIN, SLIDE .PASADOR				2	
7	4TT-25937-00	.BOOT 2 .FUNDA 2				2	
8	4JG-W0045-00	.BRAKE PAD KIT .JUEGO DE COJIN DE FRENO				1	
9	4TT-25919-00	.SUPPORT, PAD .SOPORTE DE PASTILLAS				2	
10	51L-W0048-00	.BLEED SCREW KIT ..CJTO TORNILLO DE PURGA				1	
11	90105-10638	BOLT, WASHER BASED TORNILLO CON ARANDELA				2	

FIG. 30 REAR WHEEL

RUEDA TRASERA

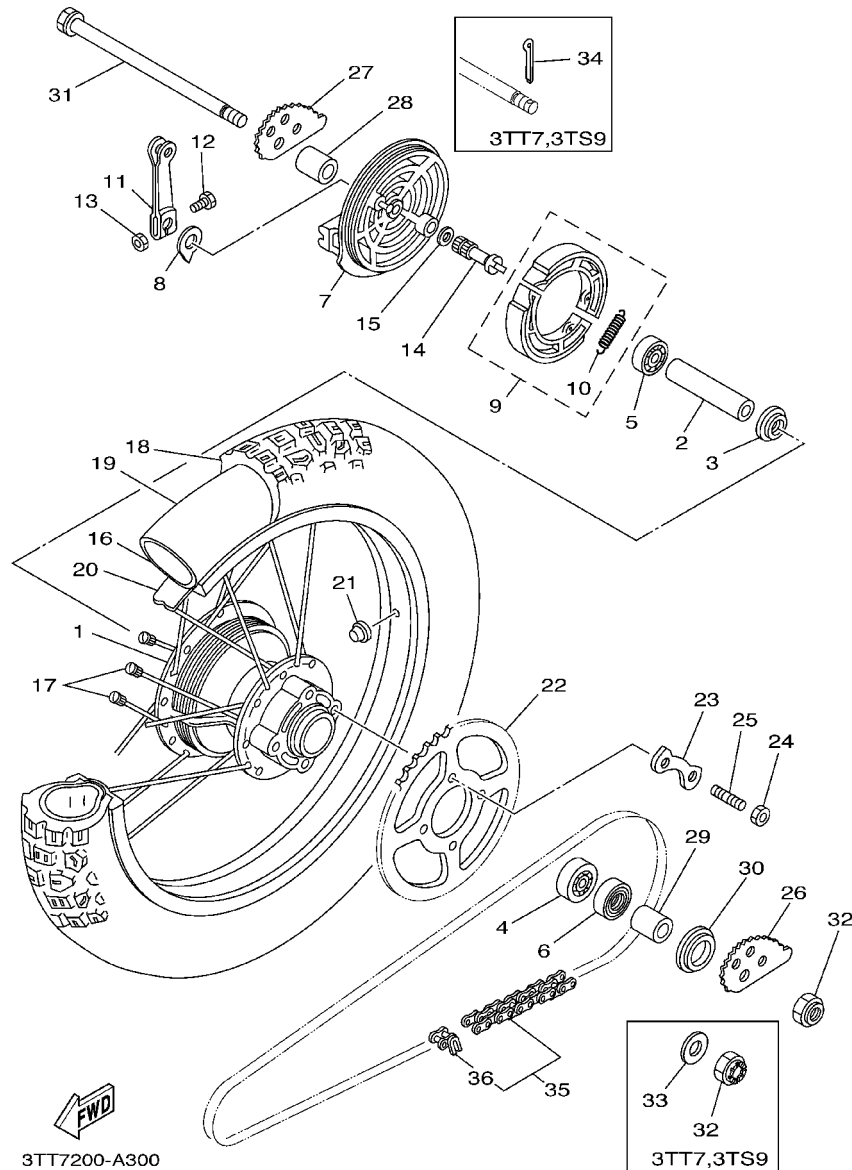

REF. NO.	PART NO. CODIGO NO.	DESCRIPTION DESCRIPTION	3TT7	3TT8	3TS9	3TSA	REMARKS OBSERVACION
1	10V-25311-00-35	HUB, REAR MASA TRASERA	1	1	1	1	SL
2	90560-15313	SPACER SEPARADOR	1	1	1	1	
3	148-25115-00	FLANGE, SPACER 1 BRIDA DE ESPACIADOR 1	1	1	1	1	
4	93306-30212	BEARING COJINETE	1	1	1	1	
5	93306-20212	BEARING COJINETE	1	1	1	1	
6	93106-26005	OIL SEAL RETEN DE ACEITE	1	1	1	1	
7	10V-25321-00-35	PLATE, BRAKE SHOE PLACA DE ZAPATA DE FRENO	1	1	1	1	SL
8	3Y6-2533A-01	PLATE, INDICATOR PLACA INDICADOR	1	1	1	1	
9	3KG-W253E-00	BRAKE SHOE KIT JUEGO DE ZAPATA DE FRENO	1	1	1	1	
10	90506-15260	.SPRING, TENSION .RESORTE DE TENSION	2	2	2	2	
11	1E2-25155-00	LEVER, CAMSHAFT 1 PALANCA DE ARBOL DE LEVAS 1	1	1	1	1	
12	90101-06278	BOLT TORNILLO	1	1	1	1	
13	95301-06600	NUT TUERCA HEXAGONAL	1	1			
	95307-06600	NUT TUERCA		1		1	
14	248-25351-10	CAMSHAFT ARBOL DE LEVAS	1	1	1	1	
15	148-25359-00	SEAL, CAMSHAFT SELLO DE ARBOL DE LEVAS	1	1	1	1	
16	94418-18007	RIM (1.85-18) ARO (1.85-18)	1	1	1	1	
17	10V-25304-01	SPOKE SET, REAR JUEGO DE RAYOS TRASEROS	1	1	1	1	
18	94141-18780	TIRE (MCS 4.10-18) NEUMATICO (MCS 4.10-18)	1	1	1	1	UR BRIDGESTONE
	94141-180A2	TIRE (4.10-18) NEUMATICO (4.10-18)	1	1	1	1	UR YOKOHAMA
19	94241-18153	TUBE (4.10-18) TUBO (4.10-18)	1	1	1	1	UR BRIDGESTONE
	94235-18085	TUBE (3.50-18) TUBO (3.50-18)	1	1	1	1	UR YOKOHAMA
20	94330-18087	BAND, RIM (3.00-18) BANDA DE ARO (3.00-18)	1	1	1	1	UR BRIDGESTONE
	94340-18065	BAND, RIM (4.00-18) BANDA DE ARO (4.00-18)	1	1	1	1	UR YOKOHAMA
21	90338-09130	PLUG TAPON	1	1	1	1	
22	3TT-25447-20	SPROCKET, DRIVEN (47T) CORONA (47T)	1	1			
	10V-25449-20	SPROCKET, DRIVEN (49T) CORONA (49T)				1	1

FIG. 30 REAR WHEEL

RUEDA TRASERA

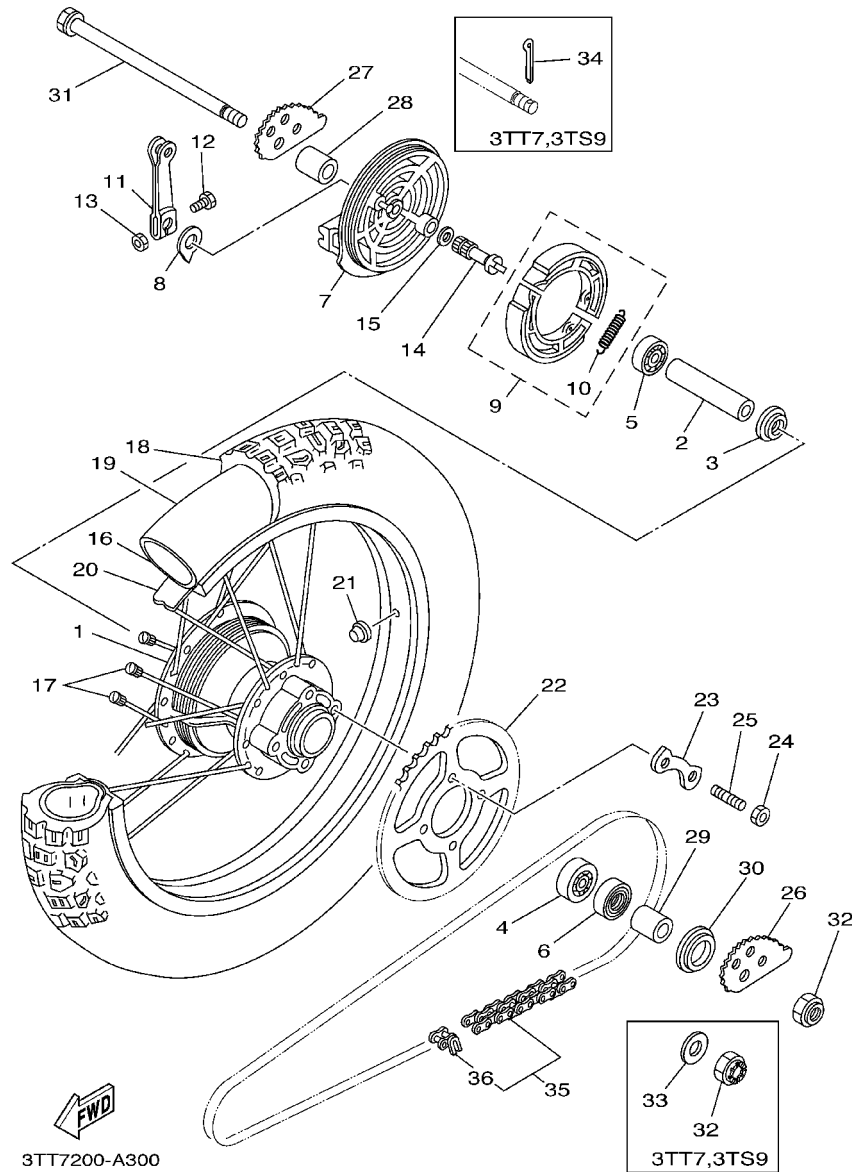

REF. NO.	PART NO. CODIGO NO.	DESCRIPTION DESCRIPTION	3TT7	3TT8	3TS9	3TSA	REMARKS OBSERVACION
23	10V-25412-00	WASHER ARANDELA	2	2	2	2	
24	90170-10219	NUT TUERCA	4	4	4	4	
25	90116-10390	BOLT, STUD ESPARRAGO	4	4	4	4	
26	1W2-25388-01	PULLER, CHAIN 1 TIRADOR DE CADENA 1	1	1	1	1	
27	1W2-25389-01	PULLER, CHAIN 2 TIRADOR DE CADENA 2	1	1	1	1	
28	90387-157F0	COLLAR COLLAR	1	1	1	1	
29	90387-157F0	COLLAR COLLAR	1	1	1	1	
30	401-25367-00	COVER, HUB DUST CUBIERTA DE MASA PARA POLVO	1	1	1	1	
31	18G-25381-00	AXLE, WHEEL EJE DE RUEDA	1				
	18G-25381-10	AXLE, WHEEL EJE DE RUEDA		1		1	
32	90171-14020	NUT, CASTLE TUERCA ENTALLADA	1				
	95607-14200	NUT, SELF-LOCKING TUERCA		1			
	95604-14200	NUT, SELF-LOCKING TUERCA DE AUTO-CIERRE				1	
33	90201-15238	WASHER, PLATE ARANDELA PLANA	1		1		
34	91401-30030	PIN, COTTER CHAVETA	1		1		
35	94580-88116	CHAIN (DID428HG-116LL) CADENA (DID428HG-116LL)	1	1			
	94580-88118	CHAIN (DID428HG-118L) CADENA (DID428HG-118L)			1	1	
36	94680-88001	.JOINT, CHAIN (DID 428HG) .CONECTOR DE CADENA (DID 428HG)	1	1	1	1	

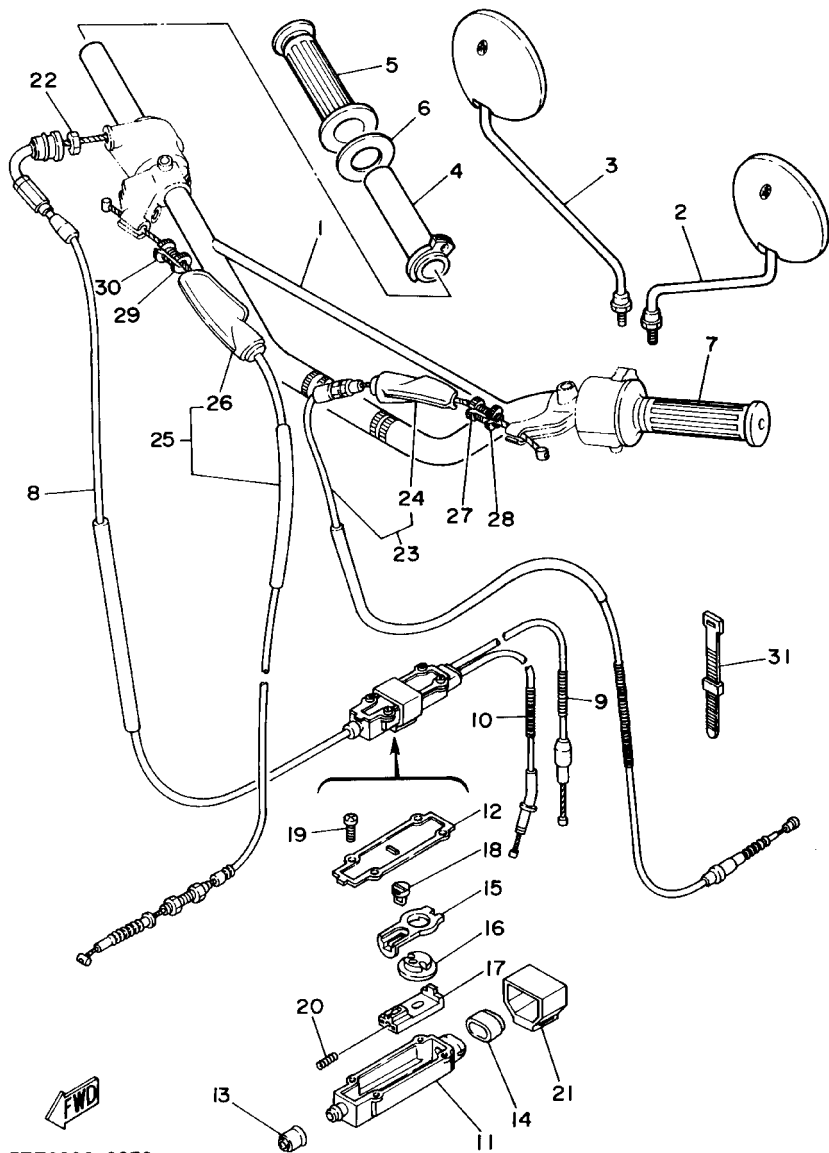

3TT2200-2270

FIG. 31 STEERING HANDLE. CABLE MANUBRIO. CABLE

REF. NO.	PART NO. CODIGO NO.	DESCRIPTION DESCRIPTION	3TT7	3TT8	3TS9	3TSA	REMARKS OBSERVACION
1	3G7-26111-00	HANDLEBAR MANUBRIO	1		1		
2	1Y1-26290-10	REAR VIEW MIRROR ASSY (L.H) ESPEJO COMPLETO (DERECHO)	1		1		
3	1Y1-26290-00	REAR VIEW MIRROR ASSY (R.H) ESPEJO COMPLETO (DERECHO)	1		1		
4	434-26243-00	TUBE, THROTTLE GUIDE TUBO DE GUIA DE OBTURADOR	1		1		
5	1A0-26242-01	GRIP (RIGHT) EMPUNADURA (MD)	1		1		
6	1M1-26249-01	RING, LEAF ANILLO DE FLEJE	1		1		
7	1E6-26241-00	GRIP EMPUNADURA	1		1		
8	3J0-26311-02	CABLE, THROTTLE 1 CABLE DE ACELERADOR 1	1		1		
9	3J1-26312-01	CABLE, THROTTLE 2 CABLE DE ACELERADOR 2	1		1		
10	18G-26321-10	CABLE, PUMP CABLE DE BOMBA	1				
	18L-26321-10	CABLE, PUMP CABLE DE BOMBA			1		
11	3J0-26261-00	CONNECTOR, CABLE CONECTOR DE CABLE	1		1		
12	3J0-26262-00	CAP, CABLE CONNECTOR TAPA DE CABLE CONECTOR	1		1		
13	360-26266-00	BOOT, CYLINDER FUNDA DE CILINDRO	1		1		
14	3J0-26272-00	CAP TAPON	1		1		
15	2T5-26274-00	GUIDE, ROTOR GUIA DE ROTOR	1		1		
16	2T5-26273-00	ROTOR ROTOR	1		1		
17	2T5-26244-00	SLIDER, THROTTLE CORREDERA DE OBTURADOR	1		1		
18	2T5-26267-00	PIN PASADOR	1		1		
19	90167-03004	SCREW, TAPPING TORNILLO DE ROSCA HEMBRA	4		4		
20	90501-05512	SPRING, COMPRESSION RESORTE DE COMPRESION	1		1		
21	3J0-26393-00	HOLDER SOPORTE	1		1		
22	90170-10038	NUT TUERCA	1		1		
23	18G-26335-00	CABLE, CLUTCH CABLE DE EMBRAGUE	1		1		
24	498-26372-00	.COVER, HANDLE LEVER 1 .CUBIERTA DE PALANCA DE MANUB 1			1		
25	18G-26341-01	CABLE, BRAKE CABLE DE FRENO	1		1		
26	498-26372-00	.COVER, HANDLE LEVER 1 .CUBIERTA DE PALANCA DE MANUB 1	1		1		

FIG. 32 STEERING HANDLE. CABLE 2 MANUBRIO. CABLE 2

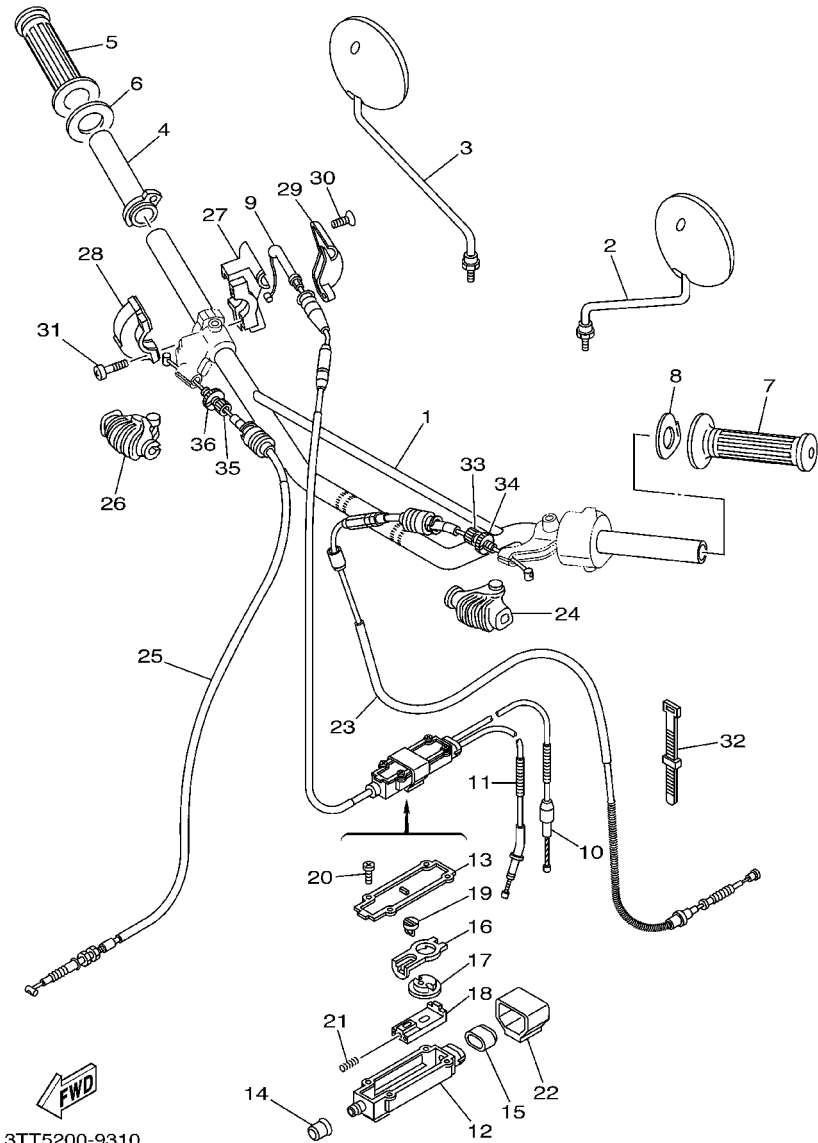

3TT5200-9310

REF. NO.	PART NO. CODIGO NO.	DESCRIPTION DESCRIPTION	3TT7	3TT8	3TS9	3TSA	REMARKS OBSERVACION
1	3TS-26111-00	HANDLEBAR MANUBRIO		1			
2	1Y1-26290-50	BACK MIRROR ASSY (L.H) ESPEJO COMPLETO (DERECHO)		1			
3	1Y1-26290-60	BACK MIRROR ASSY (R.H) ESPEJO COMPLETO (DERECHO)		1			
4	322-26243-00	TUBE, THROTTLE GUIDE TUBO DE GUIA DE OBTURADOR		1			
5	1A0-26242-01	GRIP (RIGHT) EMPUNADURA (MD)		1			
6	1M1-26249-01	RING, LEAF ANILLO DE FLEJE		1			
7	1E6-26241-00	GRIP EMPUNADURA		1			
8	4RR-26129-00	WASHER ARANDELA		1			
9	3TS-26311-00	CABLE, THROTTLE 1 CABLE DE ACELERADOR 1		1			
10	3J1-26312-01	CABLE, THROTTLE 2 CABLE DE ACELERADOR 2		1			
11	18G-26321-10	CABLE, PUMP CABLE DE BOMBA		1			
12	3J0-26261-00	CONNECTOR, CABLE CONECTOR DE CABLE		1			
13	3J0-26262-00	CAP, CABLE CONNECTOR TAPA DE CABLE CONECTOR		1			
14	156-26329-00	CAP, RUBBER TAPA DE ANILLO PROTECTOR		1			
15	3J0-26272-00	CAP TAPON		1			
16	2T5-26274-00	GUIDE, ROTOR GUIA DE ROTOR		1			
17	2T5-26273-00	ROTOR ROTOR		1			
18	2T5-26244-00	SLIDER, THROTTLE CORREDERA DE OBTURADOR		1			
19	2T5-26267-00	PIN PASADOR		1			
20	90167-03004	SCREW, TAPPING TORNILLO DE ROSCA HEMBRA		4			
21	90501-05512	SPRING, COMPRESSION RESORTE DE COMPRESION		1			
22	3J0-26393-00	HOLDER SOPORTE		1			
23	3TS-26335-00	CABLE, CLUTCH CABLE DE EMBRAGUE		1			
24	1E6-26372-00	COVER, HANDLE LEVER 1 CUBIERTA DE PALANCA DE MANUB 1		1			
25	18G-26341-10	CABLE, BRAKE CABLE DE FRENO		1			
26	1E6-26372-00	COVER, HANDLE LEVER 1 CUBIERTA DE PALANCA DE MANUB 1		1			
27	5X2-26281-00	CAP, GRIP UPPER TAPA DE EMPUNADURA SUPERIOR		1			

FIG. 33 STEERING.CABLE (DISK BRAKE) MANUBRIO CABLE(DISCO DE FRENO)

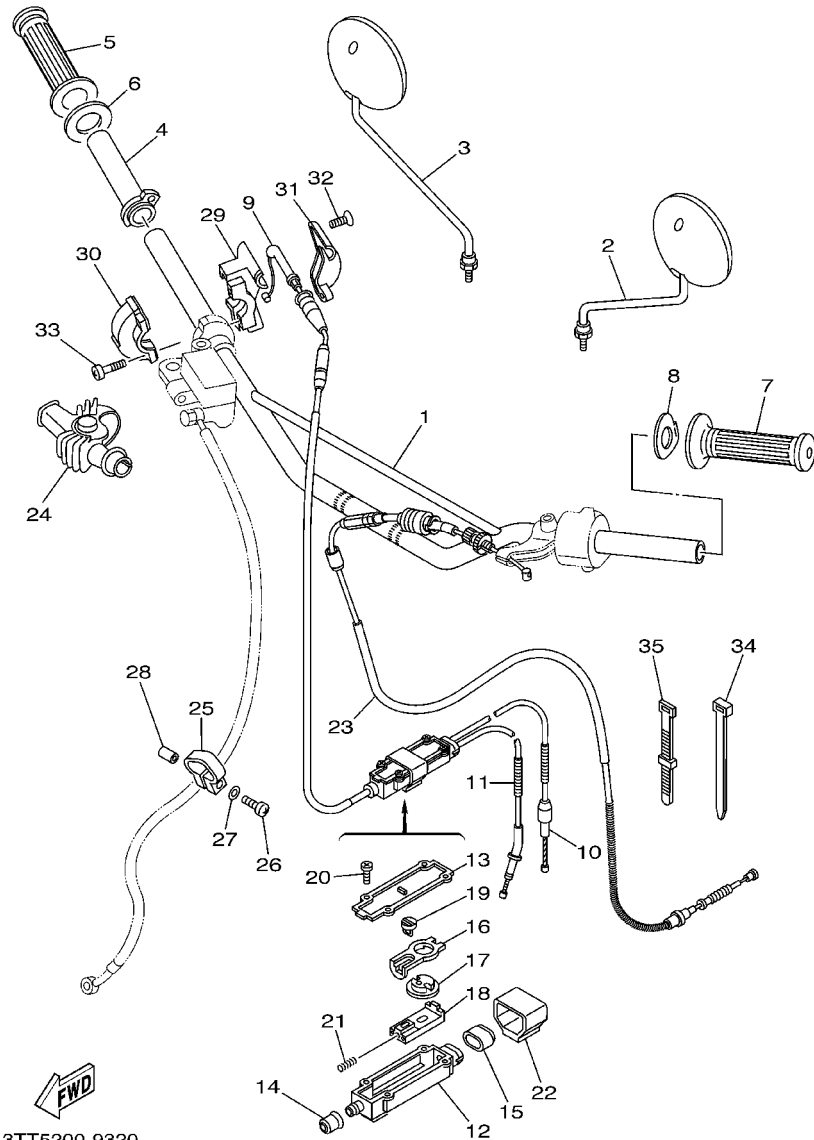

3TT5200-9320

REF. NO.	PART NO. CODIGO NO.	DESCRIPTION DESCRIPTION	3TT7	3TT8	3TS9	3TSA	REMARKS OBSERVACION
1	3TS-26111-00	HANDLEBAR MANUBRIO				1	
2	1Y1-26290-50	BACK MIRROR ASSY (L.H) ESPEJO COMPLETO (DERECHO)				1	
3	1Y1-26290-60	BACK MIRROR ASSY (R.H) ESPEJO COMPLETO (DERECHO)				1	
4	322-26243-00	TUBE, THROTTLE GUIDE TUBO DE GUIA DE OBTURADOR				1	
5	1A0-26242-01	GRIP (RIGHT) EMPUNADURA (MD)				1	
6	1M1-26249-01	RING, LEAF ANILLO DE FLEJE				1	
7	1E6-26241-00	GRIP EMPUNADURA				1	
8	4RR-26129-00	WASHER ARANDELA				1	
9	3TS-26311-00	CABLE, THROTTLE 1 CABLE DE ACELERADOR 1				1	
10	3J1-26312-01	CABLE, THROTTLE 2 CABLE DE ACELERADOR 2				1	
11	18L-26321-10	CABLE, PUMP CABLE DE BOMBA				1	
12	3J0-26261-00	CONNECTOR, CABLE CONECTOR DE CABLE				1	
13	3J0-26262-00	CAP, CABLE CONNECTOR TAPA DE CABLE CONECTOR				1	
14	156-26329-00	CAP, RUBBER TAPA DE ANILLO PROTECTOR				1	
15	3J0-26272-00	CAP TAPON				1	
16	2T5-26274-00	GUIDE, ROTOR GUIA DE ROTOR				1	
17	2T5-26273-00	ROTOR ROTOR				1	
18	2T5-26244-00	SLIDER, THROTTLE CORREDERA DE OBTURADOR				1	
19	2T5-26267-00	PIN PASADOR				1	
20	90167-03004	SCREW, TAPPING TORNILLO DE ROSCA HEMBRA				4	
21	90501-05512	SPRING, COMPRESSION RESORTE DE COMPRESION				1	
22	3J0-26393-00	HOLDER SOPORTE				1	
23	3TS-26335-00	CABLE, CLUTCH CABLE DE EMBRAGUE				1	
24	1T5-26372-00	COVER, HANDLE LEVER 1 CUBIERTA DE PALANCA DE MANUB 1				1	
25	3TB-23467-01	CLAMP GRAMPA				1	
26	98507-04018	SCREW, PAN HEAD TORNILLO DE CABEZA CON PLANA				1	
27	92907-04600	WASHER ARANDELA				1	

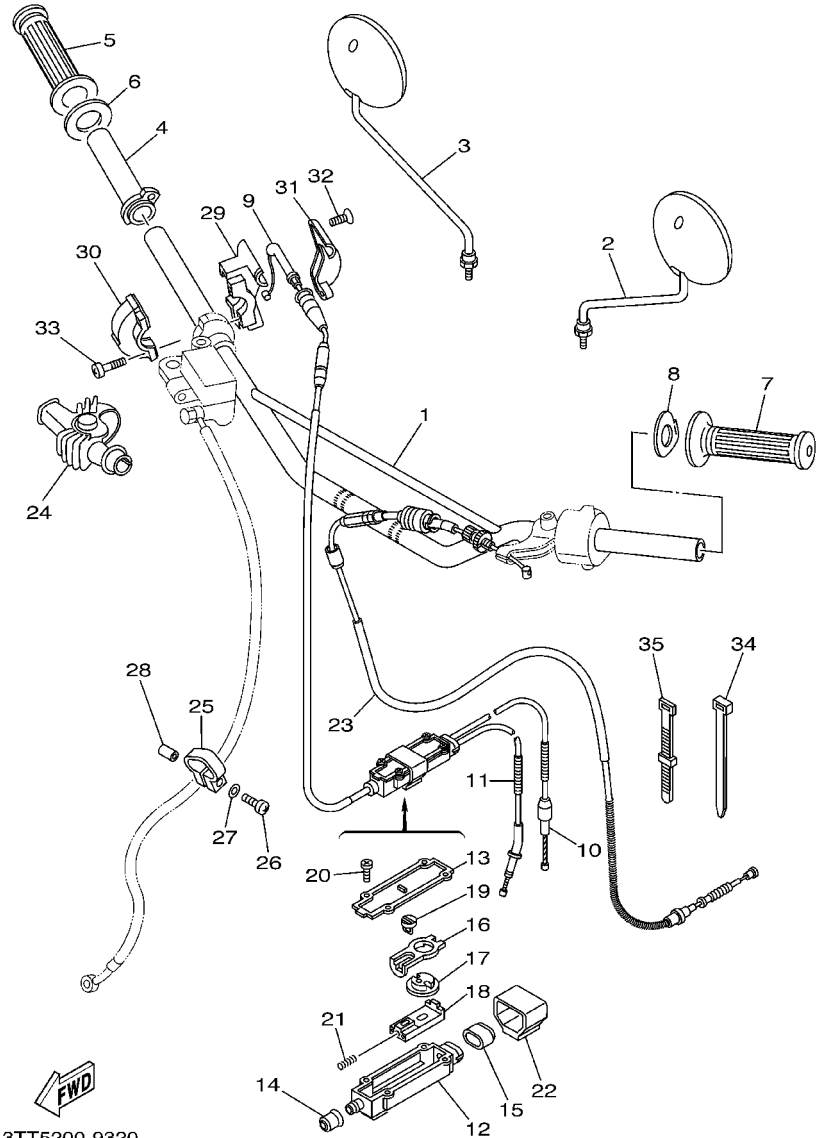

3TT5200-9320

FIG. 33 STEERING.CABLE (DISK BRAKE) MANUBRIO CABLE(DISCO DE FRENO)

REF. NO.	PART NO. CODIGO NO.	DESCRIPTION DESCRIPTION	3TT7	3TT8	3TS9	3TSA	REMARKS OBSERVACION
28	90445-057G5	HOSE (L10) TUBO (L10)				1	
29	5X2-26281-00	CAP, GRIP UPPER TAPA DE EMPUNADURA SUPERIOR				1	
30	322-26282-00	CAP, GRIP LOWER TAPA DE EMPUNADURA INFERIOR				1	
31	5X2-2628H-01	CAP, WIRE TAPA CABLE				1	
32	98707-04012	SCREW, FLAT HEAD TORNILLO DE CABEZA PLANA				2	
33	98507-05016	SCREW TORNILLO DE CABEZA CON PLANA				2	
34	1UA-82591-00	BAND BANDA				1	
35	437-83936-11	BAND, SWITCH CORD BANDA DE CABLE DE INTERRUPTOR				1	

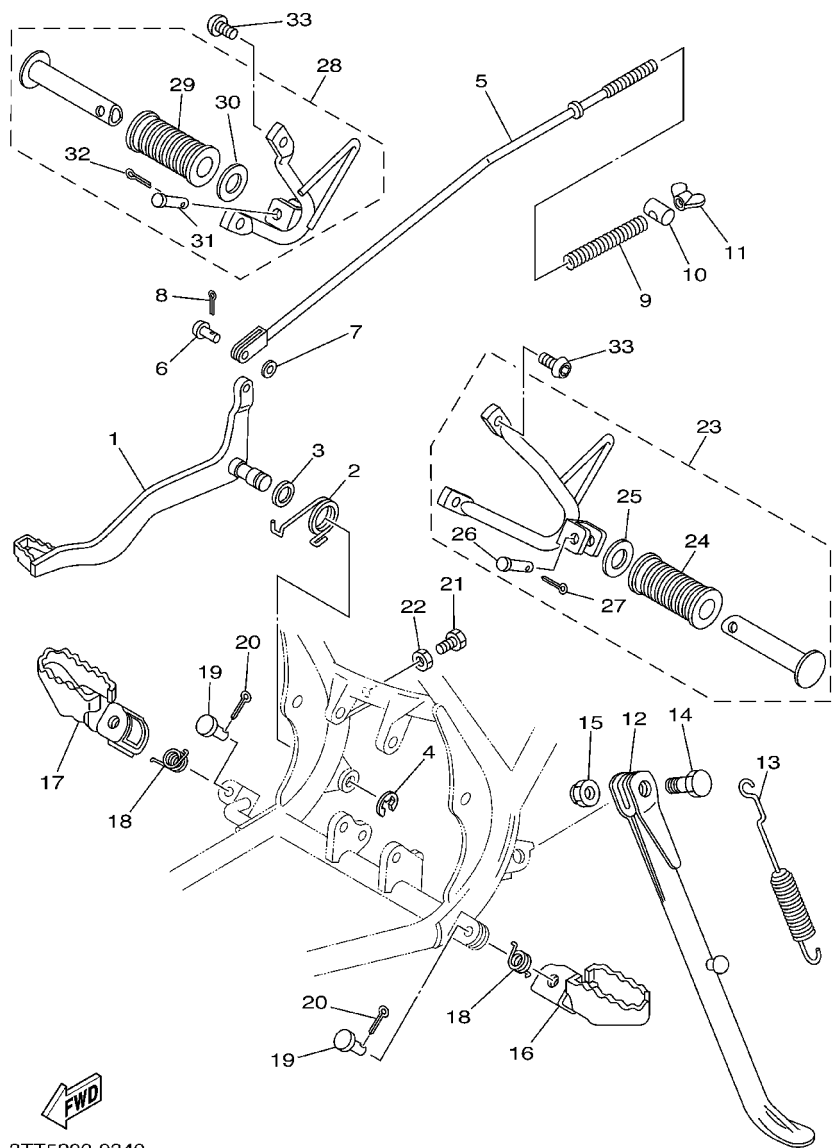

3TT5200-9340

FIG. 35 STAND. FOOTREST

SOPORTE. APOYAPIE

REF. NO.	PART NO. CODIGO NO.	DESCRIPTION DESCRIPTION	3TT7	3TT8	3TS9	3TSA	REMARKS OBSERVACION
1	2A6-27211-00	PEDAL, BRAKE PEDAL DE FRENO	1	1	1	1	
2	90508-32354	SPRING, TORSION RESORTE DE TORSION	1	1	1	1	
3	90201-14212	WASHER, PLATE ARANDELA PLANA	1	1	1	1	
4	93430-10015	CIRCLIP SEGURO	1	1	1	1	
5	18G-27231-00	ROD, BRAKE VARILLA DE FRENO	1	1	1	1	
6	90240-06076	PIN, CLEVIS PASADOR CON HOYO	1	1	1	1	
7	92907-06200	WASHER ARANDELA	1	1	1	1	
8	91401-20012	PIN, COTTER CHAVETA	1	1	1	1	
9	90501-10245	SPRING, COMPRESSION RESORTE DE COMPRESION	1	1	1	1	
10	90249-12008	PIN PASADOR	1	1	1	1	
11	90179-06411	NUT TUERCA	1	1	1	1	
12	18G-27311-00	STAND, SIDE PUNTAL LATERAL	1	1	1	1	
13	90507-29042	SPRING, TENSION RESORTE DE TENSION	1	1	1	1	
14	90109-10473	BOLT PERNO	1	1	1	1	
15	90185-10037	NUT, SELF-LOCKING TUERCA AUTOBLOCANTE	1	1	1	1	
16	3R1-27411-00-90	FOOTREST 1 APOYAPIE 1	1	1	1	1	ZK
17	3R1-27421-00-90	FOOTREST 2 APOYAPIE 2	1	1	1	1	ZK
18	90508-20023	SPRING, TORSION RESORTE DE TORSION	2	2	2	2	
19	90240-08084	PIN, CLEVIS PASADOR CON HOYO	2	2	2	2	
20	91401-25015	PIN, COTTER CHAVETA	2	2	2	2	
21	97007-06020	BOLT PERNO	1	1	1	1	
22	95307-06700	NUT TUERCA	1	1	1	1	
23	3TT-27430-00	REAR FOOTREST ASSY 1 APOYAPIE POSTERIOR COMPLETO 1		1		1	
24	120-27433-00	.COVER, REAR FOOTREST .CUBIERTA APOYAPIE TRASERO		1		1	
25	90201-20279	.WASHER, PLATE .ARANDELA PLANA		1		1	
26	91701-06032	.PIN, CLÉVIS .PASADOR		1		1	
27	91401-20012	.PIN, COTTER .CHAVETA		1		1	

FIG. 36 COWLING 1

BOVEDA 1

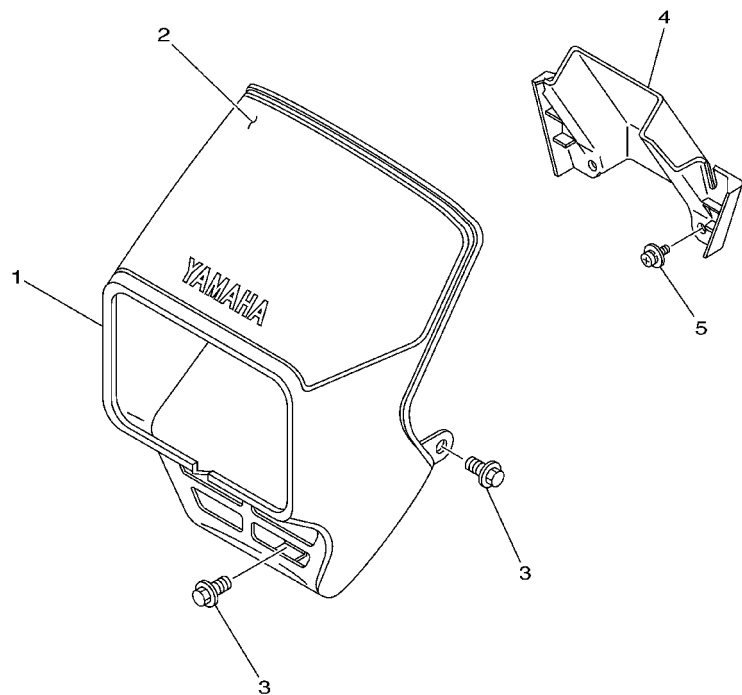

REF. NO.	PART NO. CODIGO NO.	DESCRIPTION DESCRIPTION	3TT7	3TT8	3TS9	3TSA	REMARKS OBSERVACION
1	18G-28351-10	BODY, COWLING CUERPO DE COBERTURA	1	1	1	1	UR BWC1,VRC7
	18G-28351-20	BODY, COWLING CUERPO DE COBERTURA	1	1	1	1	UR CM3
	18G-28351-02-P2	BODY, COWLING CUERPO DE COBERTURA	1	1	1	1	UR DPBMC
2	3TT-28391-00	GRAPHIC 1 CALCOMANIA DE BOVEDA 1	1	1	1	1	UR FOR BWC1
	3TT-28391-10	GRAPHIC 1 CALCOMANIA DE BOVEDA 1	1	1	1	1	UR FOR VRC7
	3TT-28391-20	GRAPHIC 1 CALCOMANIA DE BOVEDA 1	1	1	1	1	UR FOR CM3
	3TT-28391-30	GRAPHIC 1 CALCOMANIA DE BOVEDA 1	1	1	1	1	UR FOR DPBMC
3	90119-06044	BOLT, WITH WASHER TORNILLO CON ARANDELA	3	3	3	3	
4	18G-28361-00	PLATE, FRONT PLACA DELANTERA	1	1	1	1	
5	90159-06013	SCREW, WITH WASHER TORNILLO CON VALONA	2	2	2	2	



3TT7200-A360

FIG. 37 GENERATOR 1

GENERADOR 1

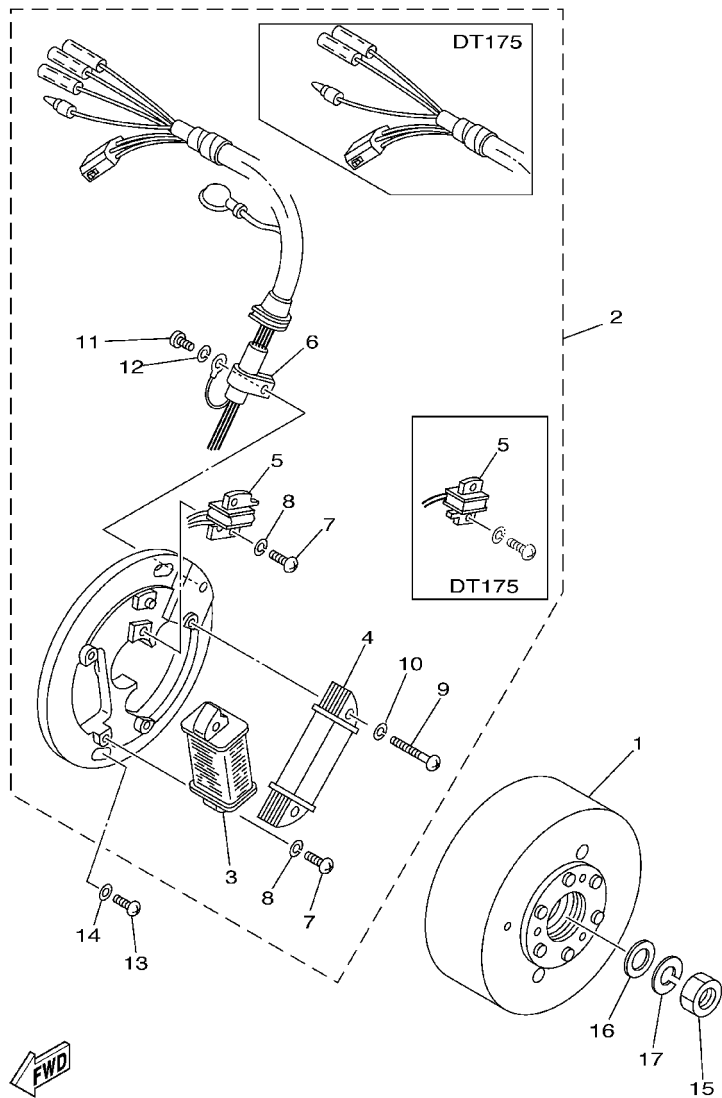

3TT7200-A370

REF. NO.	PART NO. CODIGO NO.	DESCRIPTION DESCRIPTION	3TT7	3TT8	3TS9	3TSA	REMARKS OBSERVACION
1	4AR-85550-00	ROTOR ASSY ROTOR COMPLETO	1				
	3FJ-85550-00	ROTOR ASSY ROTOR COMPLETO			1		
2	4AR-85510-00	STATOR ASSY ESTATOR COMPLET	1				
	3T6-85510-23	STATOR ASSY ESTATOR COMPLET			1		
3	3FJ-85512-00	.COIL, SOURCE .BOBINA DE FUENTE	1		1		
4	3T6-85512-00	.COIL, SOURCE .BOBINA DE FUENTE	1		1		
5	18G-85580-20	.COIL, PULSER .BOBINA DE PULSACION	1				
	3FJ-85580-00	.COIL, PULSER .BOBINA DE PULSACION			1		
6	104-81328-20	.CLAMP .GRAMPA	1		1		
7	98501-04014	.SCREW, PAN HEAD .TORNILLO DE CABEZA CRUZADA	3		3		
8	92901-04100	.WASHER, SPRING .ARANDELA PLANA	3		3		
9	98501-04030	.SCREW, PAN HEAD .TORNILLO DE CABEZA CRUZADA	2				
	98501-04032	.SCREW, PAN HEAD .TORNILLO DE CABEZA CRUZADA			2		
10	92901-04100	.WASHER, SPRING .ARANDELA PLANA	2		2		
11	98501-04006	.SCREW, PAN HEAD .TORNILLO DE CABEZA CRUZADA	1		1		
12	92901-04100	.WASHER, SPRING .ARANDELA PLANA	1		1		
13	98507-06016	SCREW TORNILLO DE CABEZA CON PLANA	2		2		
14	92907-06600	WASHER, PLATE ARANDELA	2		2		
15	90170-12347	NUT TUERCA	1		1		
16	90201-12593	WASHER, PLATE ARANDELA PLANA	1		1		
17	92907-12100	WASHER ARANDELA	1		1		

FIG. 38 GENERATOR 2

GENERADOR 2

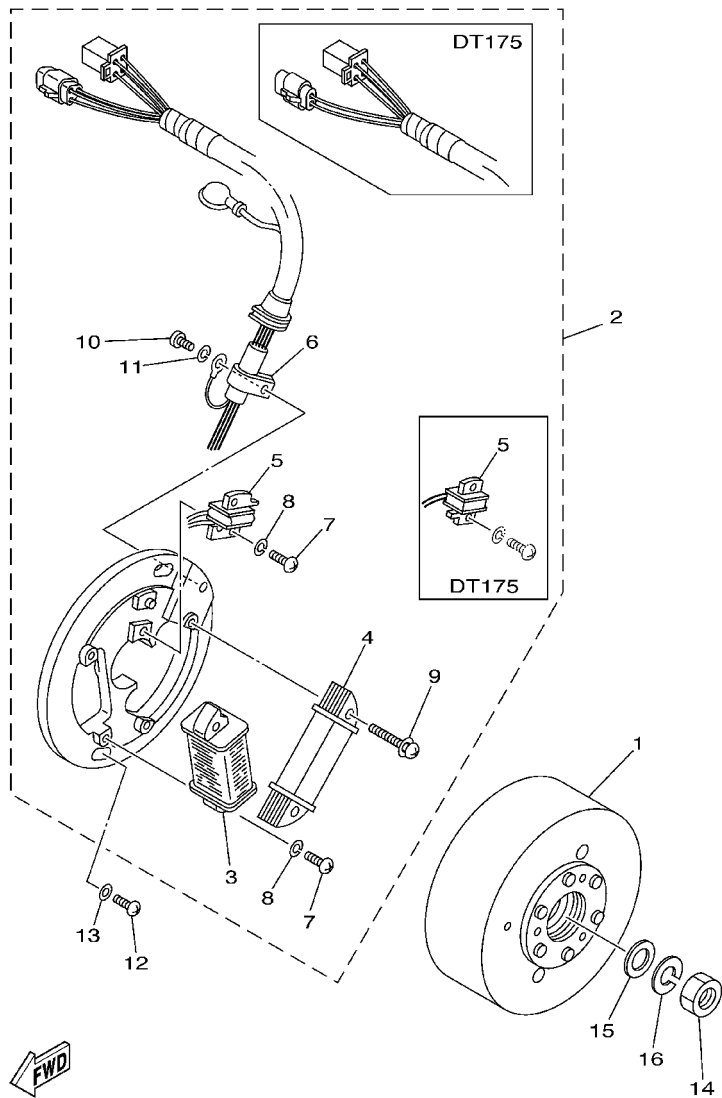

3TT5200-9361

REF. NO.	PART NO. CODIGO NO.	DESCRIPTION DESCRIPTION	3TT7	3TT8	3TS9	3TSA	REMARKS OBSERVACION
1	4AR-85550-00	ROTOR ASSY ROTOR COMPLETO		1			
	3FJ-85550-00	ROTOR ASSY ROTOR COMPLETO				1	
2	3TT-85510-00	STATOR ASSY ESTATOR COMPLET		1			
	3TS-85510-00	STATOR ASSY ESTATOR COMPLET				1	
3	3FJ-85512-00	.COIL, SOURCE .BOBINA DE FUENTE		1	1		
4	3FJ-85513-00	.COIL, LIGHTING 1 .BOBINA DE LUZ 1		1	1		
5	18G-85580-20	.COIL, PULSER .BOBINA DE PULSACION		1			
	3FJ-85580-00	.COIL, PULSER .BOBINA DE PULSACION				1	
6	104-81328-20	.CLAMP .GRAMPA		1	1		
7	98501-04014	.SCREW, PAN HEAD .TORNILLO DE CABEZA CRUZADA		3	3		
8	92901-04100	.WASHER, SPRING .ARANDELA PLANA		3	3		
9	97601-04132	.SCREW, PAN HEAD WITH WASHER .TORNILLO CON RONDONA		2	2		
10	98501-04008	.SCREW, PAN HEAD .TORNILLO DE CABEZA CRUZADA		1	1		
11	92901-04100	.WASHER, SPRING .ARANDELA PLANA		1	1		
12	98507-06016	SCREW TORNILLO DE CABEZA CON PLANA		2	2		
13	92907-06600	WASHER, PLATE ARANDELA		2	2		
14	90170-12347	NUT TUERCA		1	1		
15	90201-12593	WASHER, PLATE ARANDELA PLANA		1	1		
16	92907-12100	WASHER ARANDELA		1	1		

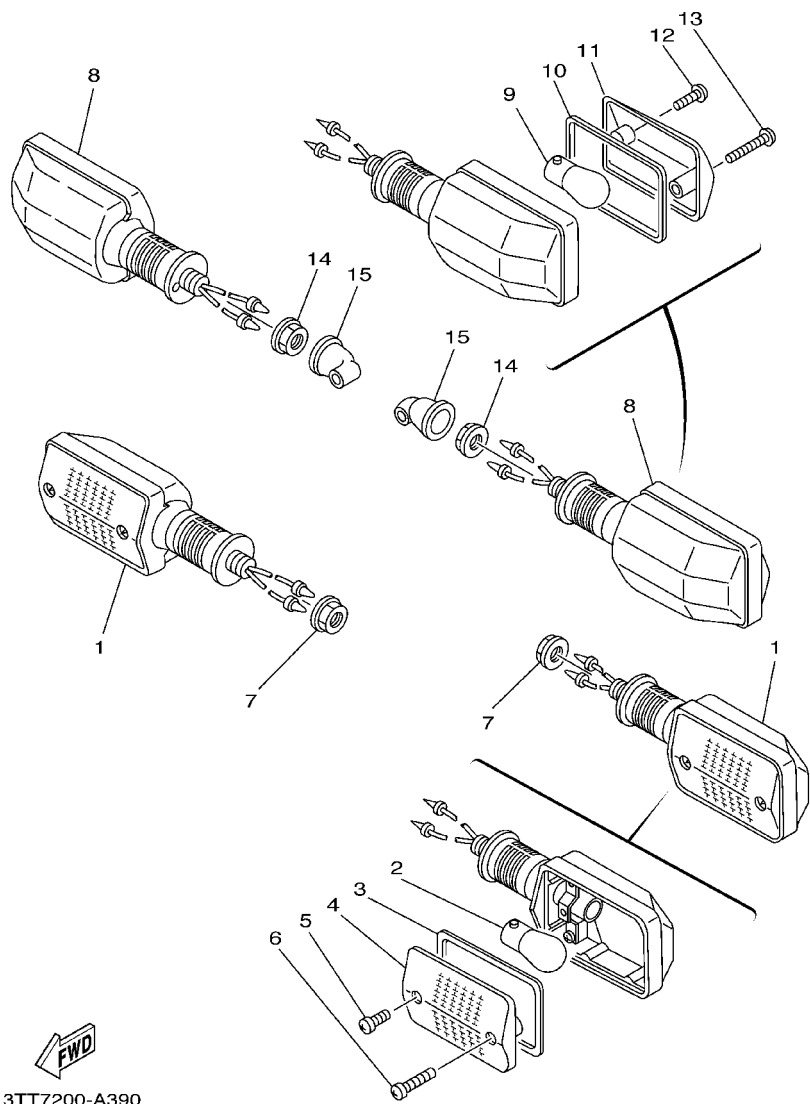

3TT7200-A390

FIG. 39 FLASHER LIGHT

LUZ DE DESTELLADOR

REF. NO.	PART NO. CODIGO NO.	DESCRIPTION DESCRIPTION	3TT7	3TT8	3TS9	3TSA	REMARKS OBSERVACION
1	18G-83310-00	FRONT FLASHER LIGHT ASSY 1 DESTELLADOR DE LUZ DELANT. 1	2		2		
2	115-83311-60	.BULB (6V-18W) .BOMBILLA DE DESTELLADOR (6V-18W)	1		1		
3	5Y1-83313-00	.GASKET, FLASHER LENS .EMPAQUE DE LENTE DESTELLADOR	1		1		
4	5Y1-83312-00	.LENS, FLASHER .LENTE DE DESTELLADOR	1		1		
5	98501-04010	.SCREW, PAN HEAD .TORNILLO DE CABEZA CRUZADA	1		1		
6	97701-40530	.SCREW, TAPPING .TORNILLO DE CABEZA CRUZADA	1		1		
7	95707-12500	NUT, FLANGE TUERCA DE BRIDA	2				
	95702-12500	NUT, FLANGE TUERCA DE REBORDE			2		
8	18G-83330-01	REAR FLASHER LIGHT ASSY 1 DESTELLADOR DE LUZ TRAS.COMPL. 1	2		2		
9	115-83311-60	.BULB (6V-18W) .BOMBILLA DE DESTELLADOR (6V-18W)	1		1		
10	5Y1-83313-00	.GASKET, FLASHER LENS .EMPAQUE DE LENTE DESTELLADOR	1		1		
11	5Y1-83312-00	.LENS, FLASHER .LENTE DE DESTELLADOR	1		1		
12	98502-04012	.SCREW, PAN HEAD .TORNILLO	1		1		
13	97702-40530	.SCREW, TAPPING .TORNILLO	1		1		
14	95707-12500	NUT, FLANGE TUERCA DE BRIDA	2				
	95702-12500	NUT, FLANGE TUERCA DE REBORDE			2		
15	18G-83365-00	CAP TAPON	2		2		

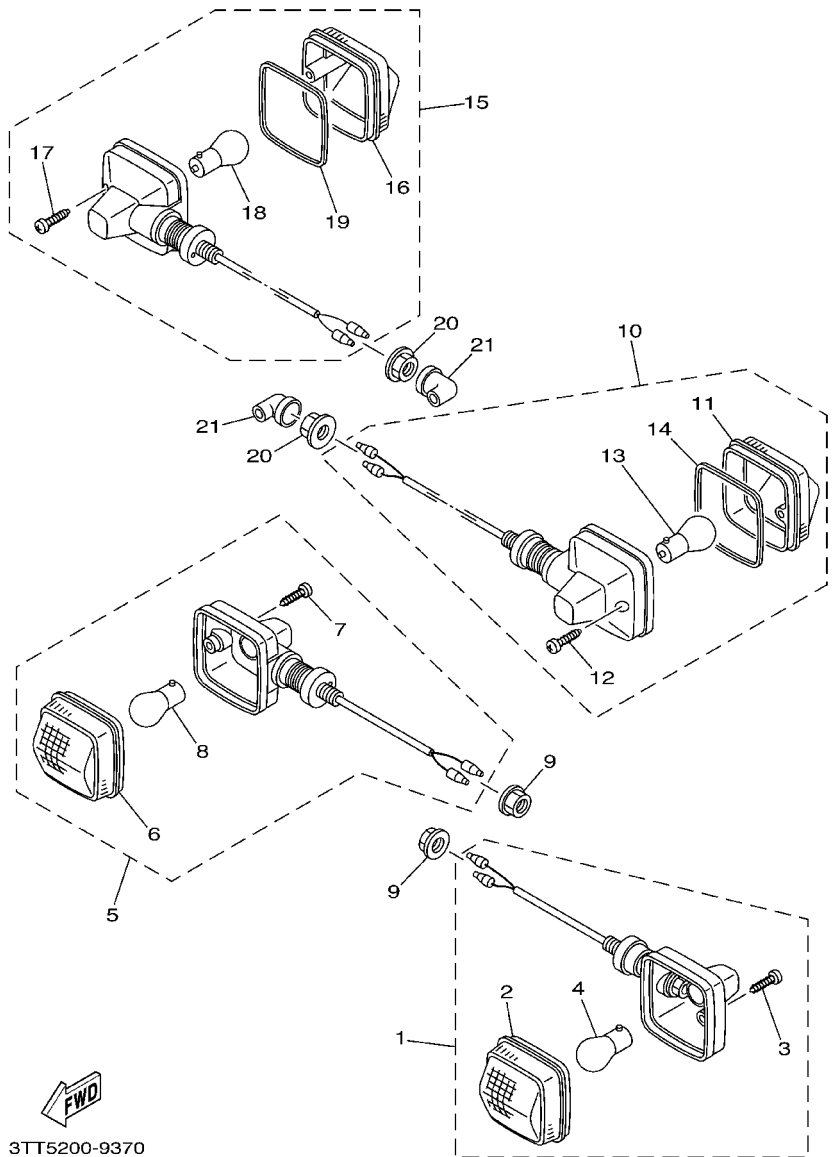

3TT5200-9370

FIG. 40 FLASHER LIGHT 2

LUZ DE DESTELLADOR 2

REF. NO.	PART NO. CODIGO NO.	DESCRIPTION DESCRIPTION	3TT7	3TT8	3TS9	3TSA	REMARKS OBSERVACION
1	3YF-83310-01	FRONT FLASHER LIGHT ASSY 1 DESTELLADOR DE LUZ DELANT. 1		1		1	
2	47J-83312-00	.LENS, FLASHER .LENTE DE DESTELLADOR		1		1	
3	97706-40620	.SCREW, TAPPING .TORNILLO, ROSCA CHAPA		1		1	
4	306-83311-40	.BULB, FLASHER (12V-21W) .BOMBILLA (12V-21W)		1		1	
5	3YF-83320-01	FRONT FLASHER LIGHT ASSY 2 DESTELLADOR DE LUZ DELANT. 2		1		1	
6	47J-83322-00	.LENS, FLASHER 2 .LENTE DE INTERMITENTE 2		1		1	
7	97706-40620	.SCREW, TAPPING .TORNILLO, ROSCA CHAPA		1		1	
8	306-83311-40	.BULB, FLASHER (12V-21W) .BOMBILLA (12V-21W)		1		1	
9	95707-12500	NUT, FLANGE TUERCA DE BRIDA		2		2	
10	3TT-83330-00	REAR FLASHER LIGHT ASSY 1 DESTELLADOR DE LUZ TRAS.COMPL. 1		1		1	
11	2KF-83332-00	.LENS, FLASHER .LENTE DE DESTELLADOR		1		1	
12	97706-40620	.SCREW, TAPPING .TORNILLO, ROSCA CHAPA		1		1	
13	306-83311-40	.BULB, FLASHER (12V-21W) .BOMBILLA (12V-21W)		1		1	
14	47J-83313-00	.GASKET, FLASHER LENS .EMPAQUE DE LENTE DESTELLADOR		1		1	
15	3TT-83340-00	FLASHER LIGHT ASSY 2 DESTELLADOR DE LUZ COMPL. 2		1		1	
16	2KF-83342-00	.LENS, FLASHER 2 .LENTE DE DESTELLADOR 2		1		1	
17	97706-40620	.SCREW, TAPPING .TORNILLO, ROSCA CHAPA		1		1	
18	306-83311-40	.BULB, FLASHER (12V-21W) .BOMBILLA (12V-21W)		1		1	
19	47J-83313-00	.GASKET, FLASHER LENS .EMPAQUE DE LENTE DESTELLADOR		1		1	
20	95707-12500	NUT, FLANGE TUERCA DE BRIDA		2		2	
21	18G-83365-00	CAP TAPON		2		2	

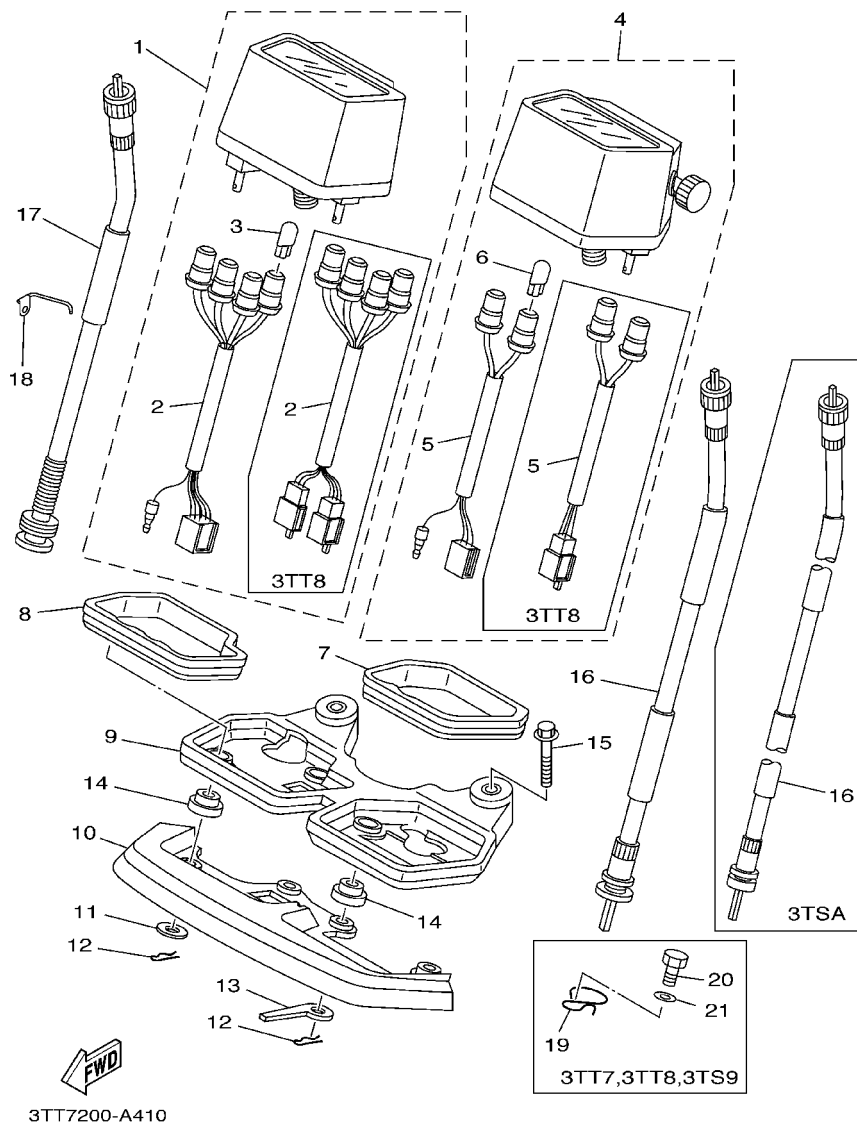

3TT7200-A410

FIG. 41 METER

MEDIDOR

REF. NO.	PART NO. CODIGO NO.	DESCRIPTION DESCRIPTION	3TT7	3TT8	3TS9	3TSA	REMARKS OBSERVACION
1	18G-83540-00	TACHOMETER ASSY TACOMETRO COMPLETO	1				
	3TT-83540-10	TACHOMETER ASSY TACOMETRO COMPLETO		1			
	18L-83540-00	TACHOMETER ASSY TACOMETRO COMPLETO			1		
	3TS-83540-00	TACHOMETER ASSY TACOMETRO COMPLETO				1	
2	18G-83520-00	.SOCKET CORD ASSY .ENCASTRE COMPLETO	1		1	1	
	3TT-83520-00	.SOCKET CORD ASSY .ENCASTRE COMPLETO		1			
3	4N0-83516-00	.BULB (6V-3W) .AMPOLLETA (6V-3W)	4				
	4R0-83517-00	.BULB (12V-3.4W T10) .AMPOLLETA (12V-3.4W T10)		4		4	
	122-83516-10	.BULB (6V-3W) .AMPOLLETA (6V-3W)			4		
4	18G-83570-F0	SPEEDOMETER ASSY VELOCIMETRO COMPLETO	1		1		KM/H
	3TT-83570-10	SPEEDOMETER ASSY VELOCIMETRO COMPLETO		1			KM/H
	3TS-83570-00	SPEEDOMETER ASSY VELOCIMETRO COMPLETO				1	KM/H
5	18G-83536-00	.SOCKET, METER .ENCASTRE DE MEDIDOR	1		1	1	
	3TT-83536-00	.SOCKET, METER .ENCASTRE DE MEDIDOR		1			
6	4N0-83516-00	BULB (6V-3W) AMPOLLETA (6V-3W)	2			2	
	4R0-83517-00	BULB (12V-3.4W T10) AMPOLLETA (12V-3.4W T10)		2		2	
7	5Y1-83513-00	DAMPER AMORTIGUADOR	1	1	1	1	
8	5Y1-83541-00	DAMPER AMORTIGUADOR	1	1	1	1	
9	5Y1-83519-00	BRACKET, METER SOPORTE DE MEDIDOR	1	1	1	1	
10	18G-83559-00	COVER, METER CUBIERTA DE MEDIDOR	1	1	1	1	
11	90201-05033	WASHER, PLATE ARANDELA PLANA	2	2	2	2	
12	437-83525-00	CLIP PRESILLA	4	4	4	4	
13	18G-83524-00	WASHER, SPECIAL ARANDELA ESPECIAL	2	2	2	2	
14	1M1-83526-00	DAMPER 2 AMORTIGUADOR 2	4	4	4	4	
15	95807-06045	BOLT, FLANGE TUERCA DE REBORDE	2	2	2		
	95807-06050	BOLT, FLANGE TUERCA DE REBORDE				2	
16	18G-83550-00	SPEEDOMETER CABLE ASSY CABLE DE VELOCIMETRO COMPLETO	1	1	1		

FIG. 42 HEADLIGHT

FARO DELANTERO

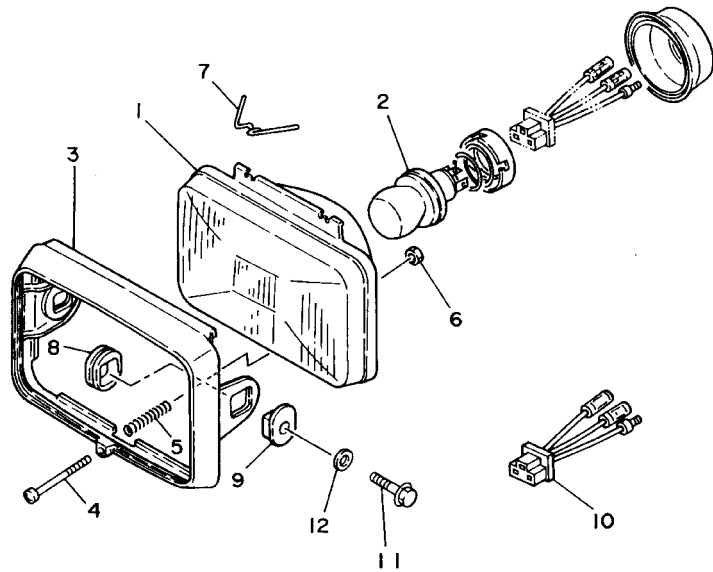

3TT4200-6330

REF. NO.	PART NO. CODIGO NO.	DESCRIPTION DESCRIPTION	3TT7	3TT8	3TS9	3TSA	REMARKS OBSERVACION
1	18G-84120-00	LENS ASSY LENTES COMPLETO	1		1		
2	17F-84114-00	BULB (6V-35/35W) AMPOLLETA DE FARO DELANTERO	1				
	18G-84114-20	BULB (6V-35/35W) AMPOLLETA DE FARO DELANTERO			1		YELLOW BULB
3	18G-84115-00	RIM, HEADLIGHT ARO DE FARO DELANTERO	1	1			
4	10X-84131-00	SCREW, RIM ADJUSTER TORNILLO AJUSTADOR DE ARO	1	1			
5	5G2-84332-60	SPRING, SCREW RESORTE DE TORNILLO	1	1			
6	198-84334-60	NUT, ADJUSTING TUERCA DE AJUSTE	1	1			
7	1M1-84124-60	SPRING, SET JUEGO DE RESORTES	2	2			
8	584-84345-60	DAMPER, HEADLIGHT AMORT DE FARO DELANTERO	2	2			
9	584-84338-60	COLLAR, BODY FITTING COLLAR ACCESORIO DE CUERPO	2	2			
10	371-84312-60	HOLDER, SOCKET ENCASTRE	1	1			
11	90105-08486	BOLT, FLANGE TORNILLO	2	2			
12	90201-08612	WASHER, PLATE ARANDELA PLANA	2	2			

FIG. 43 HEADLIGHT 2

FARO DELANTERO 2

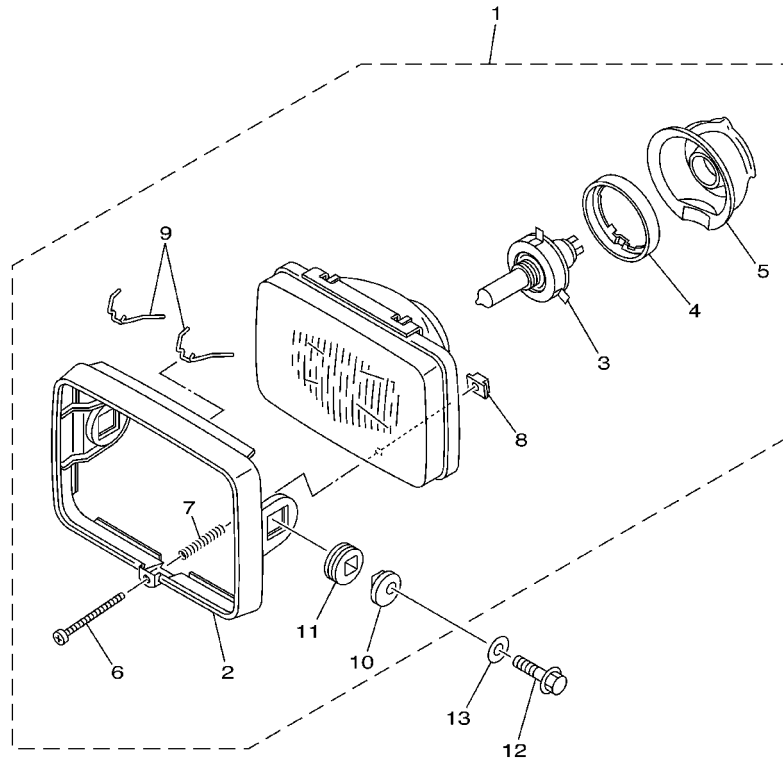

REF. NO.	PART NO. CODIGO NO.	DESCRIPTION DESCRIPTION	3TT7	3TT8	3TS9	3TSA	REMARKS OBSERVACION
1	3TT-84310-00	HEADLIGHT UNIT ASSY UNIDAD DE FARO DELANTERO COMPL		1		1	
2	18G-84115-00	.RIM, HEADLIGHT .ARO DE FARO DELANTERO		1		1	
3	1FM-84314-H0	.BULB (12V-35/35W) .BOMBILLA DE FARO DELANTERO		1		1	HALOGEN
4	2F9-84375-00	.SETTING PLATE, BULB .PLACA FIXATION DE BOMBILLO		1		1	
5	2F9-84379-01	.COVER 2 .CUBIERTA 2		1		1	
6	43F-84131-00	.SCREW, RIM ADJUSTER .TORNILLO AJUSTADOR DE ARO		1		1	
7	5G2-84332-60	.SPRING, SCREW .RESORTE DE TORNILLO		1		1	
8	198-84334-60	.NUT, ADJUSTING .TUERCA DE AJUSTE		1		1	
9	1M1-84124-60	.SPRING, SET .JUEGO DE RESORTES		2		2	
10	584-84345-60	.DAMPER, HEADLIGHT .AMORT DE FARO DELANTERO		2		2	
11	584-84338-60	.COLLAR, BODY FITTING .COLLAR ACCESORIO DE CUERPO		2		2	
12	90105-08486	BOLT, FLANGE TORNILLO		2		2	
13	90201-08612	WASHER, PLATE ARANDELA PLANA		2		2	



3TT5200-9390

FIG. 44 TAILLIGHT

LUZ DE COLA

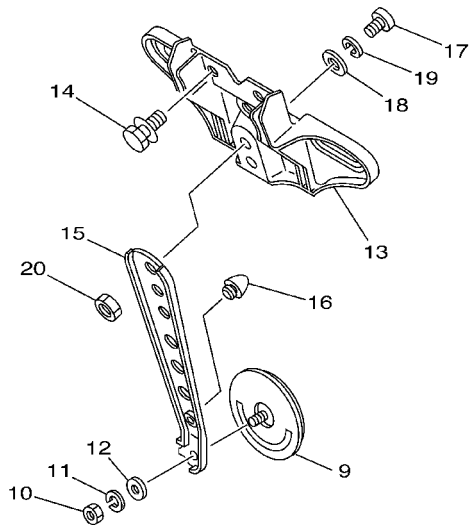
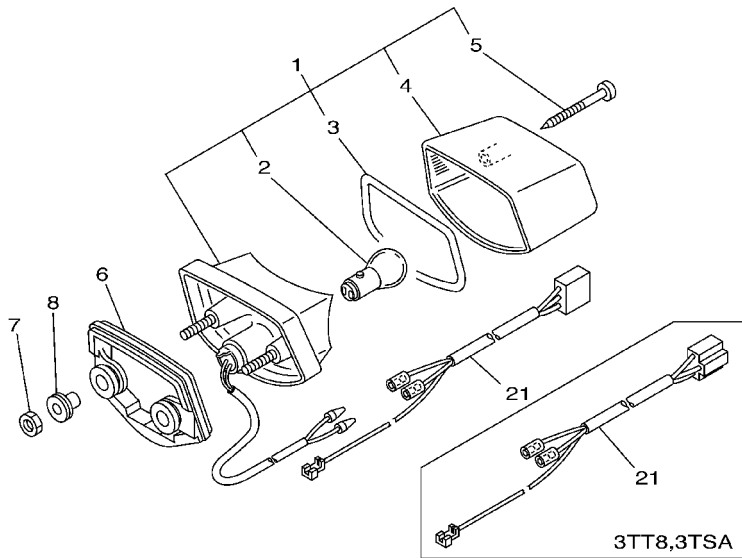



3TT7200-A440

REF. NO.	PART NO. CODIGO NO.	DESCRIPTION DESCRIPTION	3TT7	3TT8	3TS9	3TSA	REMARKS OBSERVACION
1	17F-84510-00	TAILLIGHT UNIT ASSY FARO TRASERO COMPLETO	1		1		
	37E-84710-E1	TAILLIGHT UNIT ASSY CONJT. FARO TRASERO		1		1	
2	122-84514-30	.BULB (6V-17/5.3W) .AMPOLLETA (6V-17/5.3W)	1		1		
	1A2-84714-41	.BULB (12V-21/5W) .AMPOLLETA (12V-21/5W)		1		1	
3	10V-84523-00	.GASKET, LENS .EMPAQUE DE LENTE	1	1	1	1	
4	10V-84521-00	.LENS, TAILLIGHT .LENTE DE FARO TRASERO	1		1		
	37E-84721-E1	.LENS, TAILLIGHT .LENTE DE FARO TRASERO		1		1	
5	97701-40530	.SCREW, TAPPING .TORNILLO, DE CABEZA CRUZADA	2	2	2	2	
6	18G-84736-00	DAMPER, TAIL 1 AMORTIGUADOR DE COLA 1	1	1	1	1	
7	95307-06600	NUT TUERCA	2	2	2	2	
8	90387-07391	COLLAR COLLAR	2		2		
	3TT-84557-00	COLLAR COLLAR		2		2	
9	449-85131-02	REFLECTOR, REAR 1 REFLECTOR TRASERO 1	1	1	1	1	
10	95307-05700	NUT TUERCA	1	1	1	1	
11	92907-05100	WASHER, SPRING ARANDELA	1	1	1	1	
12	92907-05200	WASHER ARANDELA	1	1	1	1	
13	18G-84551-00	BRACKET, LICENCE SOPORTE DE LICENCIA	1	1	1	1	
14	90119-06044	BOLT, WITH WASHER TORNILLO CON ARANDELA	3	3	3	3	
15	18G-85132-01	BRACKET, REFLECTOR 1 SOPORTE DE REFLECTOR 1	1	1	1	1	
16	5A8-21639-00	DAMPER 2 AMORTIGUADOR 2	1	1	1	1	
17	98507-06016	SCREW, PAN HEAD TORNILLO DE CABEZA CON PLANA	2	2	2	2	
18	90201-062A8	WASHER, PLATE ARANDELA PLANA	2	2	2	2	
19	92907-06100	WASHER, SPRING ARANDELA	2	2	2	2	
20	95307-06600	NUT TUERCA	2	2	2	2	
21	18G-84517-00	CORD, TAILLIGHT CABLE DE FARO TRASERO	1		1		
	3TT-84517-00	CORD, TAILLIGHT CABLE DE FARO TRASERO		1		1	

FIG. 45 HANDLE SWITCH. LEVER

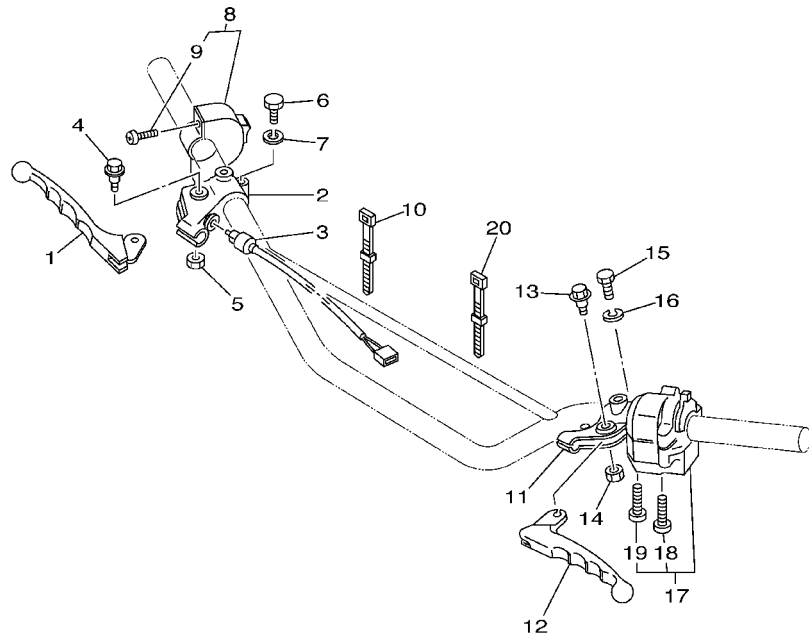
INTERRUPTOR DE MANIJA. PALANCA



REF. NO.	PART NO. CODIGO NO.	DESCRIPTION DESCRIPTION	3TT7	3TT8	3TS9	3TSA	REMARKS OBSERVACION
1	2H0-83922-30	LEVER 2 PALANCA 2	1		1		
2	361-82921-31	HOLDER, LEVER 2 SOPORTE DE LEVA 2	1		1		
3	1M1-83980-30	FRONT STOP SWITCH ASSY INTERRUP.PARADA DELANTERO	1		1		
4	90109-06799	BOLT PERNO	1		1		
5	95607-06100	NUT, U TUERCA AUTOBLOCANTE	1		1		
6	97007-06022	BOLT PERNO	1		1		
7	92907-06100	WASHER, SPRING ARANDELA	1		1		
8	18G-83976-00	SWITCH, HANDLE 1 INTERRUPTOR MANIJA 1	1		1		
9	90157-05027	.SCREW, PAN HEAD .TORNILLO CABEZA CONICA PLANA	2		2		
10	437-83936-01	BAND, SWITCH CORD BANDA DE CABLE DE INTERRUPTOR	2		2		
11	3Y6-82911-00	HOLDER, LEVER 1 SOPORTE DE LEVA 1	1		1		
12	2H0-83912-30	LEVER 1 PALANCA 1	1		1		
13	90109-06799	BOLT PERNO	1		1		
14	95607-06100	NUT, U TUERCA AUTOBLOCANTE	1		1		
15	97007-06022	BOLT PERNO	1		1		
16	92907-06100	WASHER, SPRING ARANDELA	1		1		
17	18G-83972-01	SWITCH, HANDLE 4 INTERRUPTOR DE MANIJA 4	1		1		
18	98506-05025	.SCREW, PAN HEAD .TORNILLO, DE CABEZA CRUZADA	1		1		
19	98506-05030	.SCREW, PAN HEAD .TORNILLO, DE CABEZA CRUZADA	1		1		
20	437-83936-01	BAND, SWITCH CORD BANDA DE CABLE DE INTERRUPTOR	2		2		



3TT7200-A450

FIG. 46 HANDLE SWITCH. LEVER 2 INTERRUPTOR DE MANIJA. PALANCA 2

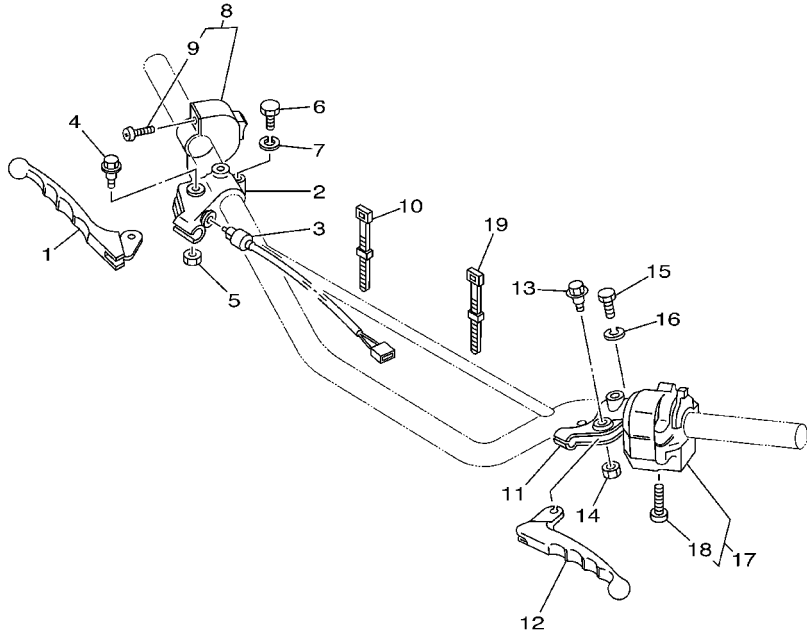

REF. NO.	PART NO. CODIGO NO.	DESCRIPTION DESCRIPTION	3TT7	3TT8	3TS9	3TSA	REMARKS OBSERVACION
1	2H0-83922-30	LEVER 2 PALANCA 2		1			
2	361-82921-31	HOLDER, LEVER 2 SOPORTE DE LEVA 2		1			
3	3TT-83980-00	FRONT STOP SWITCH ASSY INTERRUPTOR.PARADA DELANTERO		1			
4	90109-06799	BOLT PERNO		1			
5	95607-06100	NUT, U TUERCA AUTOBLOCANTE		1			
6	97007-06022	BOLT PERNO		1			
7	92907-06100	WASHER, SPRING ARANDELA		1			
8	3TS-83976-00	SWITCH, HANDLE 1 INTERRUPTOR MANIJA 1		1			
9	98507-04014	.SCREW .TORNILLO DE CABEZA CON PLANA		2			
10	437-83936-01	BAND, SWITCH CORD BANDA DE CABLE DE INTERRUPTOR		2			
11	3Y6-82911-00	HOLDER, LEVER 1 SOPORTE DE LEVA 1		1			
12	2H0-83912-30	LEVER 1 PALANCA 1		1			
13	90109-06799	BOLT PERNO		1			
14	95607-06100	NUT, U TUERCA AUTOBLOCANTE		1			
15	97007-06022	BOLT PERNO		1			
16	92907-06100	WASHER, SPRING ARANDELA		1			
17	3TS-83972-00	SWITCH, HANDLE 4 INTERRUPTOR DE MANIJA 4		1			
18	98507-05030	.SCREW .TORNILLO DE CABEZA CON PLANA		2			
19	437-83936-01	BAND, SWITCH CORD BANDA DE CABLE DE INTERRUPTOR		2			



3TT5200-9410

FIG. 48 ELECTRICAL 1

EQUIPO ELECTRICO 1

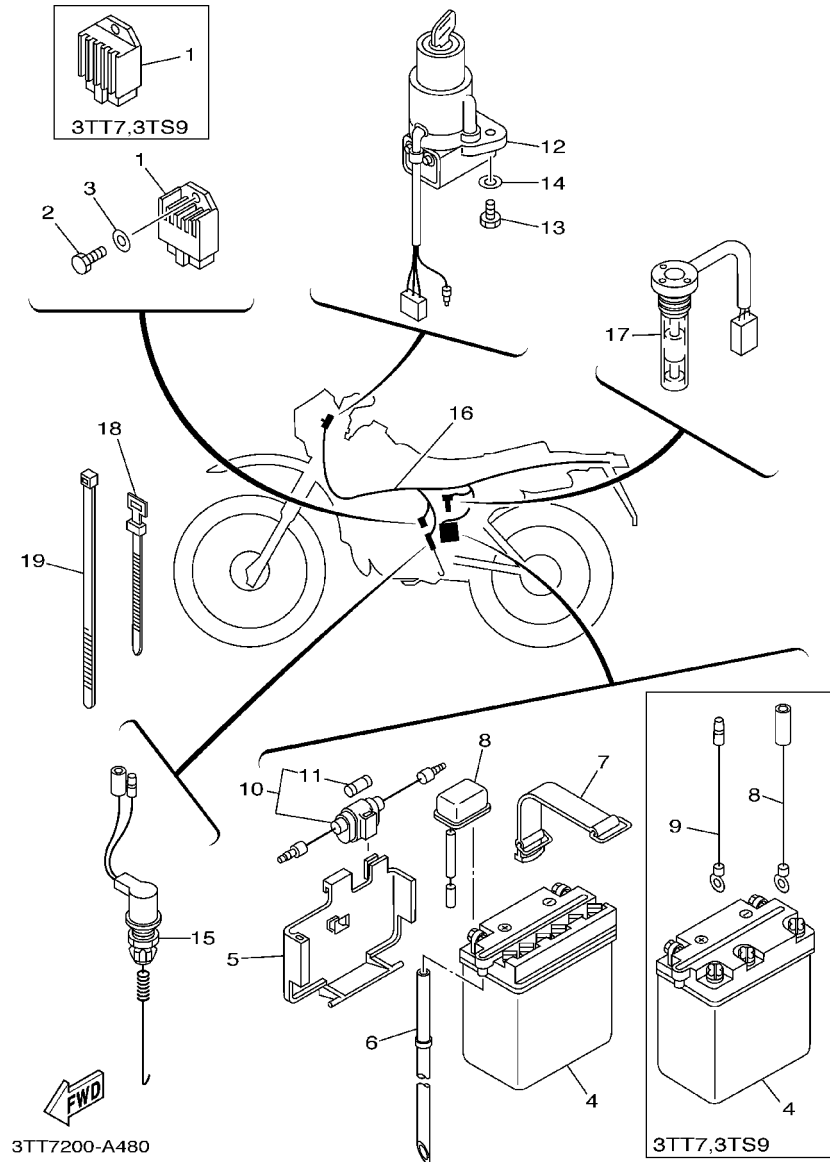

REF. NO.	PART NO. CODIGO NO.	DESCRIPTION DESCRIPTION	3TT7	3TT8	3TS9	3TSA	REMARKS OBSERVACION
1	1RH-81960-11	RECTIFIER & REGULATOR ASSY	1		1		
	4CK-81960-01	RECTIFICADOR Y REGULADOR					
	4CK-81960-01	RECTIFIER & REGULATOR ASSY		1		1	
	4CK-81960-01	RECTIFICADOR Y REGULADOR					
2	97007-06014	BOLT	1	1	1	1	
	97007-06014	PERNO					
3	92907-06600	WASHER, PLATE	1	1	1	1	
	92907-06600	ARANDELA					
4	1E6-82110-13	BATTERY ASSY (6N6-3B-1)	1		1		
	1E6-82110-13	BATERIA COMPLETA (6N6-3B-1)					
	30W-82110-01	BATTERY ASSY (GM3-3B)		1		1	
	30W-82110-01	BATERIA COMPLETA (GM3-3B)					
5	18G-82122-01	SEAT, BATTERY	1	1	1	1	
	18G-82122-01	ASIENTO DE BATERIA					
6	90445-08357	HOSE (L350)	1	1	1	1	
	90445-08357	TUBO (L350)					
7	18G-82131-00	BAND, BATTERY	1	1	1	1	
	18G-82131-00	TIRANTE DE BATERIA					
8	2A6-82115-00	WIRE, PLUS LEAD	1		1		
	2A6-82115-00	CABLE CONDUCTOR POSITIVO					
	2RH-82115-00	WIRE, PLUS LEAD		1		1	
	2RH-82115-00	CABLE CONDUCTOR POSITIVO					
9	1E6-81949-00	WIRE, LEAD	1		1		
	1E6-81949-00	CABLE CONDUCTOR					
10	55K-82150-01	FUSE HOLDER ASSY	1	1	1	1	
	55K-82150-01	PORTA-FUSIBLES COMPLETO					
11	116-82151-00	FUSE (10A)	2	2	2	2	
	116-82151-00	FUSIBLE (10A)					
12	18G-82501-00	MAIN SWITCH STEERING LOCK	1		1		
	18G-82501-00	LLAVE DE IGNICION COMPLT					
	3TT-82501-00	MAIN SWITCH STEERING LOCK		1		1	
	3TT-82501-00	LLAVE DE IGNICION COMPLT					
13	97007-06016	BOLT	2	2	2	2	
	97007-06016	PERNO					
14	92907-06600	WASHER, PLATE	2	2	2	2	
	92907-06600	ARANDELA					
15	3J0-82530-02	STOP SWITCH ASSY	1	1	1	1	
	3J0-82530-02	INTERRUPTOR DE PARADA COMPLETO					
16	3TT-82590-00	WIRE HARNESS ASSY	1				
	3TT-82590-00	CONJUNTO DE CABLES					
	3TT-82590-10	WIRE HARNESS ASSY		1			
	3TT-82590-10	CONJUNTO DE CABLES					
	3TS-82590-00	WIRE HARNESS ASSY			1		
	3TS-82590-00	CONJUNTO DE CABLES					
	3TS-82590-10	WIRE HARNESS ASSY				1	
	3TS-82590-10	CONJUNTO DE CABLES					
17	3J0-85720-00	OIL LEVEL GAUGE ASSY	1	1	1	1	
	3J0-85720-00	MEDIDOR DE NIVEL DE ACEITE					
18	437-83936-01	BAND, SWITCH CORD	4		4		
	437-83936-01	BANDA DE CABLE DE INTERRUPTOR					
19	1UA-82591-00	BAND		8		8	
	1UA-82591-00	BANDA					

FIG. 49 ELECTRICAL 2

EQUIPO ELECTRICO 2

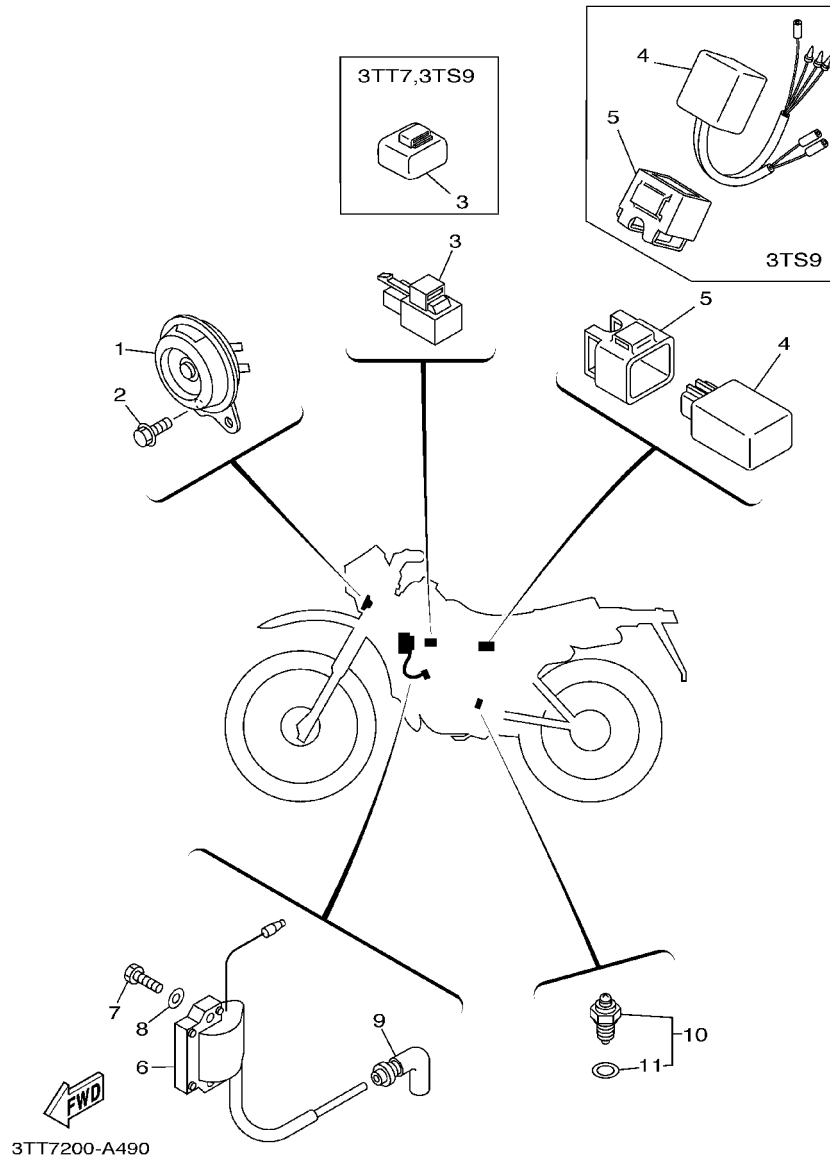

REF. NO.	PART NO. CODIGO NO.	DESCRIPTION DESCRIPTION	3TT7	3TT8	3TS9	3TSA	REMARKS OBSERVACION
1	18G-83371-10	HORN BOCINA	1		1		
	4GL-83371-00	HORN BOCINA		1		1	
2	95807-06010	BOLT, FLANGE TUERCA DE REBORDE	2	2	2	2	
3	3BK-83350-00	FLASHER RELAY ASSY RELE DE DESTELLADOR COMPL.	1		1		
	3GM-83350-01	FLASHER RELAY ASSY RELE DE DESTELLADOR COMPL.			1	1	
4	4AR-85540-00	C.D.I. UNIT ASSY UNIDAD C.D.I. COMPLETA	1	1			
	3J0-85540-20	C.D.I. UNIT ASSY UNIDAD C.D.I. COMPLETA			1		
	3TS-85540-00	C.D.I. UNIT ASSY UNIDAD C.D.I. COMPLETA				1	
5	2A7-85546-00	BAND BANDA	1	1	1	1	
6	4AR-82310-00	IGNITION COIL ASSY BOBINA DE ENCENDIDO COMPLETA	1				
	3TT-82310-00	IGNITION COIL ASSY BOBINA DE ENCENDIDO COMPLETA		1		1	
	4V5-82310-40	IGNITION COIL ASSY BOBINA DE ENCENDIDO COMPLETA			1		
7	97007-06020	BOLT PERNO	2	2	2	2	
8	92907-06600	WASHER, PLATE ARANDELA	2	2	2	2	
9	1M1-82370-30	PLUG CAP ASSY TAPON DE BUJIA COMPLT	1	1	1	1	
10	136-82540-03	NEUTRAL SWITCH ASSY INTERRUPTOR NEUTRAL COMPL	1	1	1	1	
11	136-82543-00	.GASKET .EMPAQUE	1	1	1	1	

NUMERICAL INDEX
INDICE NUMERICO

PART NO. CODIGO NO.	REF. NO.	PART NO. CODIGO NO.	REF. NO.	PART NO. CODIGO NO.	REF. NO.	PART NO. CODIGO NO.	REF. NO.	PART NO. CODIGO NO.	REF. NO.	PART NO. CODIGO NO.	REF. NO.
3RW-W0041-02	34-2	3M5-11681-00	2-5	10V-14190-20	5-4	2JK-16111-01	10-1	3TT-21110-01-P2	15-1	18G-21751-00	18-1
4JG-W0045-00	29-8	5Y9-12491-00	15-10	214-14195-00	5-6	3TL-16150-00	10-4	3TT-21110-01-33	15-1	179-21771-00	18-2
4JG-W0047-00	29-5	18G-13101-00	3-1	183-14196-00	5-23	598-16321-01	10-7	3TT-21110-10-P0	15-1	18G-22110-00	19-1
51L-W0048-00	29-10	18L-13101-00	3-1	18G-1441K-00	4-26	1V1-16324-00	10-8	3TT-21110-10-33	15-1	18G-22110-10	19-1
4JG-W0057-00	29-4	126-13116-01	3-15	18G-14411-00	4-11	18G-16351-00	10-9	3J0-21170-01	15-11	18G-22124-00	19-3
3H3-W0092-00	25-9	363-13133-01	3-22	18G-14412-00	4-12	1W1-16356-02	10-17	5G3-21308-01	15-8	18G-22128-00	20-8
3KG-W253E-00	27-9	137-13137-00-03	3-8	3TK-14451-00	4-13	2X3-16357-00	10-20	5H0-21308-01	15-8	401-22128-01	19-4
	30-9	137-13137-00-05	3-8	18G-14452-00	4-16	1W1-16358-01	10-16	3RW-21511-B0	16-1	3J0-22131-00	19-28
18G-Y2410-00-01	25-1	137-13137-00-10	3-8	18G-14453-01	4-17	18G-16371-00	10-6	3RW-21511-60	16-1	1W1-22128-00	19-5
18G-Y2410-00-02	25-1	137-13138-01	3-7	18G-14458-00	4-14	18L-16371-00	10-6	3RW-21511-70	16-1	3J0-22147-00	19-27
18G-Y2410-00-03	25-1	18G-13174-00	3-29	18G-14465-00	4-28	18G-16380-02	10-22	37N-21511-20	16-1	2A6-22151-00	19-8
18G-Y2410-00-04	25-1	275-13175-01	3-13	3TK-14472-00	4-20	4J3-17121-00	11-2	37N-21511-30	16-1	2A6-22152-00	19-9
18G-Y2410-20-04	25-1	522-13175-01	3-13	18G-14493-00	4-15	4J3-17131-00	11-3	37N-21511-60	16-1	2N0-22178-00	19-21
18G-Y2410-20-05	25-1	137-13176-00	3-18	18G-14610-01	6-1	4J3-17151-01	11-4	4BE-21511-00	16-1	2A6-22179-00	19-19
18G-Y2410-20-06	25-1	2A6-13178-00	3-19	18L-14610-01	6-1	4J3-17161-00	11-5	4BE-21511-10	16-1	1W1-22187-00	19-22
18G-Y2410-20-07	25-1	402-13552-00	3-2	3PA-14613-10	6-2	4J3-17211-00	11-9	4BE-21511-20	16-1	18G-22210-02	20-1
18G-11111-00	1-1	10V-13565-01	4-7	1W2-14714-00	6-15	4J3-17221-00	11-10	37N-21611-20	16-4	3R4-22226-00	20-3
18L-11111-00	1-1	18G-13581-00	4-25	18G-14718-00	6-7	4J3-17231-00	11-11	37N-21611-50	16-4	4F2-22311-01	19-14
18G-11127-00	1-9	18G-13584-00	4-27	18G-14753-00	6-10	4J3-17241-00	11-12	18G-21620-00	16-6	2A6-22318-00	19-10
18G-11128-00	1-5	10V-13610-01	4-1	10V-14758-00	6-17	4J3-17251-00	11-13	18G-21620-10	16-6	18G-23102-00	23-1
18G-11161-00	1-3	10V-13613-01	4-2	2A6-14726-00	6-4	4J3-17261-00	11-14	1M1-21621-00	16-8	3TS-23102-00	24-1
363-11161-00	1-2	10V-13616-01	4-3	18G-1490J-00	5-8	4J3-17411-00	11-1	168-21638-00	6-11	18G-23103-00	23-18
18G-11162-00	1-4	3TT-13621-00	4-6	18L-1490J-00	5-8	137-17417-00-05	9-8	2A6-21639-00	16-7	3TS-23103-00	24-18
4F2-11162-00	1-2	18G-14101-00	5-1	18L-15111-01	7-1	2A6-17421-00	11-8	5A8-21639-00	44-16	3TS-23106-00	24-2
2A6-11181-00	1-10	18L-14101-00	5-1	2A6-15111-03	7-1	1W1-17471-01	11-27	3TT-21708-00	17-4	3TT-23106-20	23-2
2A7-11181-10	1-10	18G-14103-00	5-15	18L-15121-01	7-2	2A6-17831-01	12-2	4L8-21708-00	17-4	3TS-23107-00	24-19
18G-11311-01	1-6	10W-14104-00	5-20	2A6-15121-02	7-2	2A6-17841-00	12-5	18G-21711-10	17-1	3TT-23107-20	23-19
18L-11311-00	1-6	10X-14106-00	5-16	304-15128-00	7-16	248-17861-00	12-1	18G-21711-20	17-1	18G-23110-00	23-7
18G-11351-02	1-12	314-14112-25	5-18	328-15316-00	7-5	4F2-18101-02	14-5	18G-21721-10	17-3		23-24
3TN-11351-00	1-12	500-14115-00	5-12	401-15317-00	7-6	2A6-18111-00	14-8	18G-21721-20	17-3		24-7
18G-11400-00	2-1	2A6-14126-00	5-21	18G-15362-00	8-10	132-18113-01	14-9	3TS-2173E-A0	17-9		24-24
1W1-11412-01	2-2	2N4-14131-00	5-22	2N4-15371-00	7-12	4F2-18120-00	14-1	3TS-2173E-B0	17-9	1U6-23111-M1	23-15
1W1-11422-01	2-3	2F5-14141-36	5-9	1W1-15381-00	11-25	1W1-18140-00	13-13	3TS-2173E-C0	17-9		23-32
3TK-11603-00	2-9	2F5-14141-38	5-9	2A7-15411-01	8-1	401-18178-00	14-6	3TS-2173E-D0	17-9		24-15
3TL-11603-00	2-9	260-14142-20	5-2	18G-15416-00	8-12	1W1-18185-00	13-3	3TT-2173E-A0	17-9		24-32
3TK-11604-00	2-9	260-14142-22	5-2	18G-15431-01	8-5	1W1-18197-01	14-15	3TT-2173E-B0	17-9	240-23114-00	23-16
3TL-11604-00	2-9	137-14143-33	5-3	18G-15451-03	8-6	2A6-18511-00	13-9	3TT-2173E-C0	17-9		23-33
3TK-11605-00	2-9	137-14143-34	5-3	2A6-15455-01	8-2	2A6-18512-00	13-10	3TT-2173E-D0	17-9		24-16
3TL-11605-00	2-9	137-14143-35	5-3	18G-15456-02	8-13	2A6-18531-00	13-11	3TS-2173F-A0	17-10		24-33
18G-11631-01-96	2-8	2N4-14145-00	5-11	2A6-15484-01	8-4	2A6-18535-00	13-12	3TS-2173F-B0	17-10	5N8-23118-00	23-14
18L-11631-00-97	2-8	214-14147-00	5-10	156-15618-01	9-16	1W1-18540-00	13-1	3TS-2173F-C0	17-10		23-31
251-11633-00	2-11	558-14147-00	5-13	2A6-15620-02	9-10	136-18542-00	13-2	3TS-2173F-D0	17-10		24-14
4Y2-11633-00	2-11	1M1-14169-00	5-19	1W1-15621-01	9-11	1W1-18561-00	13-5	3TT-2173F-A0	17-10		24-31
18G-11635-01	2-8	4U5-14171-00	5-17	1W1-15641-00	9-2	3TT-21107-00	15-11	3TT-2173F-B0	17-10	1H3-23125-00	23-6
18L-11635-00	2-8	304-14184-00	5-14	525-15651-00	9-7	3TS-21110-01-P2	15-1	3TT-2173F-C0	17-10		23-23
18G-11636-01	2-8	314-14185-00	5-7	4F2-15660-01	9-1	3TS-21110-01-33	15-1	3TT-2173F-D0	17-10		24-6
18L-11636-00	2-8	127-14186-00	5-5	1W1-15666-00	9-6	3TS-21110-10-P0	15-1	3TT-2174G-00	17-11		24-23
4Y2-11651-00	2-4	1V0-14190-25	5-4	401-15676-00	9-4	3TS-21110-10-33	15-1	3TT-2174H-00	17-12	18G-23141-00	23-12

NUMERICAL INDEX
INDICE NUMERICO

PART NO. CODIGO NO.	REF. NO.	PART NO. CODIGO NO.	REF. NO.	PART NO. CODIGO NO.	REF. NO.	PART NO. CODIGO NO.	REF. NO.	PART NO. CODIGO NO.	REF. NO.	PART NO. CODIGO NO.	REF. NO.
18G-23141-00	23 - 29	18G-2331E-00	21 - 23	18G-24731-91	26 - 2	3RW-25867-00	34 - 6	5X2-2628H-01	32 - 29	120-27433-00	35 - 29
	24 - 12		22 - 21	18G-24734-B0	26 - 8	5RS-25870-00	34 - 1		33 - 31	3TT-27440-00	35 - 28
	24 - 29	18G-23317-00	23 - 42	18G-24734-10	26 - 8	3TS-25872-00	34 - 9	5X2-26281-00	32 - 27	2A6-28100-00	15 - 14
3R2-23144-00	23 - 5	34X-23317-00	22 - 15	18G-24734-90	26 - 8	3RW-25875-00	34 - 12		33 - 29	2A6-28100-10	15 - 14
	23 - 22	3Y1-23319-00	21 - 18	18G-24738-00	26 - 3	34X-25876-00	22 - 13	322-26282-00	32 - 28	18G-28351-02-P2	36 - 1
	24 - 5	18G-23340-00	23 - 38	18G-24770-B0	26 - 1	36Y-2589H-00	34 - 5		33 - 30	18G-28351-10	36 - 1
	24 - 22	3TS-23340-00	24 - 38	18G-24770-12	26 - 1	5JW-25914-00	29 - 6	1Y1-26290-00	31 - 3	18G-28351-20	36 - 1
1T3-23145-00	23 - 4	3TS-23346-00	23 - 41	18G-24770-91	26 - 1	4TT-25919-00	29 - 9	1Y1-26290-10	31 - 2	18G-28361-00	36 - 4
	23 - 21		24 - 39	3TT-24830-00	26 - 12	4TT-25937-00	29 - 7	1Y1-26290-50	32 - 2	3TT-28391-00	36 - 2
	24 - 4	18G-23389-00	21 - 20	2A6-25104-01	27 - 24	3G7-26111-00	31 - 1		33 - 2	3TT-28391-10	36 - 2
	24 - 21	156-2341E-00	21 - 10	34Y-25104-00	28 - 6	3TS-26111-00	32 - 1	1Y1-26290-60	32 - 3	3TT-28391-20	36 - 2
3DM-23149-10	23 - 13		22 - 7	2A6-25111-00-35	27 - 1		33 - 1		33 - 3	3TT-28391-30	36 - 2
	23 - 30	22F-2341E-00	21 - 13	34X-25111-02-35	28 - 1	4RR-26129-00	32 - 8	3J0-26311-02	31 - 8	104-81328-20	37 - 6
	24 - 13		22 - 10	148-25115-00	30 - 3		33 - 8	3TS-26311-00	32 - 9		38 - 6
	24 - 30	156-23411-00	23 - 40	2K5-25118-00	27 - 30	1E6-26241-00	31 - 7		33 - 9	1E6-81949-00	48 - 9
4A1-23156-00	23 - 3		24 - 43	322-25118-00	28 - 12		32 - 7	3J1-26312-01	31 - 9	1RH-81960-11	48 - 1
	23 - 20	22F-23411-01	21 - 11	3TL-25121-00-35	27 - 6		33 - 7		32 - 10	4CK-81960-01	48 - 1
	24 - 3		22 - 8	5J0-25135-00	27 - 11	1A0-26242-01	31 - 5		33 - 10	1E6-82110-13	48 - 4
	24 - 20	156-23412-00	21 - 9	109-25136-00	27 - 12		32 - 5	18G-26321-10	31 - 10	30W-82110-01	48 - 4
509-23158-L0	23 - 10		22 - 6	102-25137-00	27 - 36		33 - 5		32 - 11	2A6-82115-00	48 - 8
	23 - 27	22F-23412-01	21 - 12	5J0-25138-00	27 - 13	322-26243-00	32 - 4	18L-26321-10	31 - 10	2RH-82115-00	48 - 8
	24 - 10		22 - 9	183-25149-00	27 - 17		33 - 4		33 - 11	18G-82122-01	48 - 5
	24 - 27	583-23416-01	21 - 14	1E2-25155-00	30 - 11	434-26243-00	31 - 4	156-26329-00	32 - 14	18G-82131-00	48 - 7
1U6-23168-M0	23 - 17		22 - 11	2N4-25155-00	27 - 19	2T5-26244-00	31 - 17		33 - 14	55K-82150-01	48 - 10
	23 - 34	18G-23435-00	21 - 1	33M-25181-00	28 - 13		32 - 18	18G-26335-00	31 - 23	116-82151-00	48 - 11
	24 - 17	3TS-23435-00	22 - 1	34X-25190-01	28 - 15		33 - 18	3TS-26335-00	32 - 23	3TT-82310-00	49 - 6
	24 - 34	1E6-23441-10-98	21 - 7	10V-25304-01	30 - 17	1M1-26249-01	31 - 6		33 - 23	4AR-82310-00	49 - 6
18G-23170-00	23 - 9		22 - 4	10V-25311-00-35	30 - 1		32 - 6	18G-26341-01	31 - 25	4V5-82310-40	49 - 6
	23 - 26	164-23462-00	23 - 39	109-25315-00	27 - 5		33 - 6	18G-26341-10	32 - 25	1M1-82370-30	49 - 9
	24 - 9		24 - 44	10V-25321-00-35	30 - 7	3J0-26261-00	31 - 11	1E6-26372-00	32 - 24	18G-82501-00	48 - 12
	24 - 26	3TB-23467-01	33 - 25	3Y6-2533A-01	27 - 8		32 - 12		32 - 26	3TT-82501-00	48 - 12
1W1-23173-L0	23 - 8	278-24181-00	25 - 3		30 - 8		33 - 12		47 - 20	3J0-82530-02	48 - 15
	23 - 25	18G-24182-00	25 - 4	248-25351-10	27 - 22	3J0-26262-00	31 - 12	1T5-26372-00	33 - 24	136-82540-03	49 - 10
	24 - 8	18G-24183-01	25 - 5		30 - 14		32 - 13	498-26372-00	31 - 24	136-82543-00	49 - 11
	24 - 25	18G-24186-01	25 - 6	148-25359-00	30 - 15		33 - 13		31 - 26	3TS-82590-00	48 - 16
18G-23174-00	21 - 21	3TT-24240-60	25 - 2	401-25367-00	30 - 30	360-26266-00	31 - 13	3J0-26393-00	31 - 21	3TS-82590-10	48 - 16
18G-23174-10	22 - 19	3TT-24240-70	25 - 2	18G-25381-00	30 - 31	2T5-26267-00	31 - 18		32 - 22	3TT-82590-00	48 - 16
278-23181-50	23 - 11	3TT-24240-80	25 - 2	18G-25381-10	30 - 31		32 - 19		33 - 22	3TT-82590-10	48 - 16
	23 - 28	3TT-24240-90	25 - 2	353-25381-00	27 - 31		33 - 19	2A6-27211-00	35 - 1	1UA-82591-00	33 - 34
	24 - 11	18G-24500-02	25 - 8	1W2-25388-01	30 - 26	3J0-26272-00	31 - 14	18G-27231-00	35 - 5		48 - 19
	24 - 28	2W6-24512-00	25 - 11	1W2-25389-01	30 - 27		32 - 15	18G-27311-00	35 - 12	1LN-82911-00	47 - 11
18G-23191-00	23 - 35	2G2-24522-00	25 - 13	10V-25412-00	30 - 23		33 - 15	3R1-27411-00-90	35 - 16	3Y6-82911-00	45 - 11
	24 - 35	11H-24602-03	25 - 20	3TT-25447-20	30 - 22	2T5-26273-00	31 - 16	3R1-27421-00-90	35 - 17		46 - 11
	23 - 36	3Y1-24602-01	25 - 20	10V-25449-20	30 - 22		32 - 17	3TT-27430-00	35 - 23	33G-82913-01	47 - 12
18G-23192-00	24 - 36	18A-24723-00	26 - 5	4JG-2580T-00	29 - 3		33 - 17	120-27431-00	19 - 34	361-82921-31	45 - 2
509-23194-L0	23 - 37	509-24724-00	26 - 6	4JG-2582T-10	29 - 1	2T5-26274-00	31 - 15	120-27432-02	19 - 31		46 - 2
	24 - 37	18G-24731-B0	26 - 2	4GY-25852-01	34 - 4		32 - 16	120-27433-00	19 - 32	18G-83310-00	39 - 1
10V-2331E-02	24 - 40	18G-24731-12	26 - 2	5RB-25854-00	34 - 3		33 - 16		35 - 24	3YF-83310-01	40 - 1

NUMERICAL INDEX
INDICE NUMERICO

PART NO. CODIGO NO.	REF. NO.	PART NO. CODIGO NO.	REF. NO.	PART NO. CODIGO NO.	REF. NO.	PART NO. CODIGO NO.	REF. NO.	PART NO. CODIGO NO.	REF. NO.	PART NO. CODIGO NO.	REF. NO.
115-83311-60	39-2	18G-83560-F0	41-17	584-84338-60	43-11	90105-10638	29-11	90170-08029	14-12	90201-20279	35-25
	39-9	18G-83570-F0	41-4	584-84345-60	42-8	90105-14220	21-2	90170-10038	31-22		35-30
306-83311-40	40-4	3TS-83570-00	41-4		43-10		22-2	90170-10219	30-24	90201-22555	11-15
	40-8	3TT-83570-10	41-4	2F9-84375-00	43-4	90109-063F7	13-14	90170-12347	37-15	90202-05187	6-9
	40-13	2A6-83595-00	41-19	2F9-84379-01	43-5	90109-065G4	29-2		38-14		6-19
	40-18	3TT-83599-00	41-18	17F-84510-00	44-1	90109-06577	47-2	90170-14171	10-15	90202-05193	25-15
47J-83312-00	40-2	2H0-83912-30	45-12	122-84514-30	44-2	90109-06799	45-4	90170-22187	17-5	90204-12007	10-2
5Y1-83312-00	39-4		46-12	18G-84517-00	44-21		45-13	90171-10004	27-34	90209-18135	11-16
	39-11	23X-83912-00	47-13	3TT-84517-00	44-21		46-4	90171-14020	30-32	90209-22071	2-6
47J-83313-00	40-14	2H0-83922-30	45-1	10V-84521-00	44-4		46-13	90179-06013	18-8	90215-08014	14-13
	40-19		46-1	10V-84523-00	44-3		47-14	90179-06411	35-11	90215-14122	10-14
5Y1-83313-00	39-3	55Y-83922-00	47-1	18G-84551-00	44-13	90109-10453	20-4	90179-08148	31-28	90215-16127	11-31
	39-10	437-83936-01	45-10	3TT-84557-00	44-8	90109-10473	35-14		31-30	90240-06076	35-6
3YF-83320-01	40-5		45-20	37E-84710-E1	44-1	90109-10533	19-25		32-34	90240-08084	35-19
47J-83322-00	40-6		46-10	1A2-84714-41	44-2	90116-06016	1-8		32-36	90240-12092	20-9
18G-83330-01	39-8		46-19	37E-84721-E1	44-4	90116-08394	1-7		47-19	90249-12008	35-10
3TT-83330-00	40-10		47-10	18G-84736-00	44-6	90116-10278	1-13	90179-08299	1-11	90280-03017	2-19
2KF-83332-00	40-11		47-23	449-85131-02	44-9	90116-10279	1-14	90179-10279	1-16	90282-05005	2-20
3TT-83340-00	40-15		48-18	18G-85132-01	44-15	90116-10390	30-25	90179-12659	10-3	90338-09130	27-28
2KF-83342-00	40-16	437-83936-11	31-31	3TS-85510-00	38-2	90119-05020	10-11	90179-16226	11-32		28-10
3BK-83350-00	49-3		32-32	3TT-85510-00	38-2	90119-05059	19-17	90179-25033	21-15		30-21
3GM-83350-01	49-3		33-35	3T6-85510-23	37-2	90119-05193	19-30		22-12	90338-18122	15-13
18G-83365-00	39-15	18G-83972-01	45-17	4AR-85510-00	37-2	90119-06018	34-13	90185-08089	15-6	90340-12005	7-14
	40-21	3TS-83972-00	46-17	3FJ-85512-00	37-3	90119-06044	16-5	90185-10037	35-15	90380-12051	20-2
	49-1		47-21		38-3		16-9	90185-12046	19-6	90381-08002	12-4
18G-83371-10	49-1			3T6-85512-00	37-4		36-3	90201-05033	41-11	90386-18028	19-2
4GL-83371-00	49-1	18G-83976-00	45-8	3FJ-85513-00	38-4		44-14	90201-062A8	44-18	90387-05682	19-29
5Y1-83513-00	41-7	3TS-83976-00	46-8	3J0-85540-20	49-4	90119-06056	4-29	90201-07076	27-15	90387-06681	16-3
122-83516-10	41-3		47-8	3TS-85540-00	49-4	90119-06063	16-2	90201-08612	42-12	90387-07391	4-19
4N0-83516-00	41-3	1M1-83980-30	45-3	4AR-85540-00	49-4	90122-06001	18-7		43-13		18-9
	41-6	3TS-83980-00	47-7	2A7-85546-00	49-5	90123-08046	31-27	90201-08624	3-14		44-8
4R0-83517-00	41-3	3TT-83980-00	46-3	3FJ-85550-00	37-1		31-29	90201-10118	34-11	90387-07789	16-3
	41-6	17F-84114-00	42-2		38-1		32-33	90201-10123	12-3	90387-093H1	6-12
5Y1-83519-00	41-9	18G-84114-20	42-2	4AR-85550-00	37-1		32-35	90201-12163	12-6	90387-12265	27-29
18G-83520-00	41-2	18G-84115-00	42-3		38-1		47-18		14-16	90387-15600	28-11
3TT-83520-00	41-2		43-2		37-5	90149-06011	25-14	90201-12541	9-14	90387-157F0	30-28
18G-83524-00	41-13	18G-84120-00	42-1	18G-85580-20	38-5	90149-06131	47-4	90201-12593	37-16		30-29
437-83525-00	41-12	1M1-84124-60	42-7		37-5	90149-08108	10-26		38-15	90387-202A0	11-29
1M1-83526-00	41-14		43-9	3FJ-85580-00	38-5	90149-08111	14-11	90201-12749	27-32	90387-20488	2-18
18G-83536-00	41-5	10X-84131-00	42-4		48-17	90157-05027	45-9	90201-14212	35-3	90401-10159	34-10
3TT-83536-00	41-5	43F-84131-00	43-6	3J0-85720-00	27-20	90157-08131	7-17	90201-14217	10-24	90430-04004	3-5
18G-83540-00	41-1	3TT-84310-00	43-1	90101-06278	30-12	90159-05018	19-18	90201-15238	30-33	90430-08216	10-25
18L-83540-00	41-1	371-84312-60	42-10		15-12	90159-06013	17-2	90201-15700	11-18	90430-12227	7-15
3TS-83540-00	41-1	1FM-84314-H0	43-3	90101-06529	15-2		36-5	90201-17550	10-5	90445-05681	3-11
3TT-83540-10	41-1	5G2-84332-60	42-5	90105-08099	15-3	90167-03004	31-19		10-13	90445-057G5	33-28
5Y1-83541-00	41-8		43-7	90105-08120	42-11		32-20	90201-20266	11-6	90445-07176	25-17
18G-83550-00	41-16	198-84334-60	42-6	90105-08486	43-12		33-20	90201-20269	27-16	90445-07340	7-13
3Y0-83550-01	41-16		43-8		15-4	90170-06010	47-5	90201-20279	19-33	90445-083J4	3-27
18G-83559-00	41-10	584-84338-60	42-9	90105-10037							

NUMERICAL INDEX
INDICE NUMERICO

PART NO. CODIGO NO.	REF. NO.	PART NO. CODIGO NO.	REF. NO.	PART NO. CODIGO NO.	REF. NO.	PART NO. CODIGO NO.	REF. NO.	PART NO. CODIGO NO.	REF. NO.	PART NO. CODIGO NO.	REF. NO.
90445-083J7	18 - 3	90560-12138	27 - 3	92907-06600	19 - 12	93310-216A3	2 - 10	95027-08012	6 - 6	95827-08035	22 - 5
90445-08357	48 - 6	90560-15290	28 - 3		34 - 8	93310-216E1	2 - 10	95027-08040	22 - 3	95827-10055	21 - 5
90445-095A1	25 - 17	90560-15313	30 - 2		37 - 14	93310-42231	2 - 7	95027-08055	21 - 3	97007-06012	41 - 20
90445-104H8	25 - 16	90560-17147	10 - 12		38 - 13	93311-31515	11 - 23	95301-05600	3 - 10	97007-06014	48 - 2
90450-44046	4 - 8	91317-06010	22 - 14		41 - 21	93311-41530	11 - 20	95301-06600	27 - 21	97007-06016	19 - 11
90460-37026	6 - 16	91317-08025	9 - 17		48 - 3	93315-21813	13 - 8		30 - 13		48 - 13
90460-49058	4 - 21	91401-20012	19 - 36		48 - 14	93410-20038	11 - 7	95302-10700	20 - 6	97007-06020	35 - 21
90464-16061	15 - 10		35 - 8		49 - 8	93410-22039	11 - 17	95307-05600	22 - 18		49 - 7
90466-35001	21 - 16		35 - 27	92907-08100	6 - 14	93430-08006	13 - 6	95307-05700	19 - 23	97007-06022	45 - 6
90467-07029	25 - 19		35 - 32	92907-08200	15 - 5	93430-08007	9 - 15		44 - 10		45 - 15
90467-08075	3 - 28	91401-20020	27 - 35		26 - 9	93430-10015	35 - 4	95307-06600	10 - 19		46 - 6
	18 - 4	91401-20025	20 - 7	92907-08600	26 - 11	93440-15012	9 - 9		30 - 13		46 - 15
	25 - 19	91401-25015	35 - 20	92907-10100	15 - 7		11 - 19		44 - 7	97007-06025	4 - 9
90467-09006	25 - 18	91401-25020	20 - 11	92907-10200	20 - 5	93450-17025	2 - 12		44 - 20		4 - 23
90467-13073	4 - 31	91401-30030	30 - 34	92907-12100	19 - 7	93450-17044	2 - 12	95307-06700	35 - 22		34 - 7
90467-20050	4 - 30	91701-06032	19 - 35		37 - 17	93503-16003	9 - 13	95307-10700	20 - 6	97007-08016	26 - 10
90468-02033	3 - 12		35 - 26		38 - 16		10 - 21	95307-12700	19 - 37	97007-08020	26 - 10
	3 - 26		35 - 31	92907-12600	20 - 10	93505-32002	3 - 3	95604-14200	28 - 14	97027-06012	11 - 28
90468-08086	3 - 25	92017-08016	35 - 33	93101-10001	3 - 17	93603-22028	3 - 20		30 - 32	97027-06020	14 - 10
90468-26048	9 - 3	92502-06008	25 - 12	93101-12173	14 - 14	93604-12037	13 - 4	95607-06100	45 - 5	97507-08625	6 - 13
90468-26183	9 - 3	92901-04100	37 - 8	93101-17062	9 - 18	93604-30018	13 - 7		45 - 14	97601-04132	38 - 9
90480-12053	17 - 7		37 - 10	93102-18008	27 - 4	93822-15065	11 - 30		46 - 5	97701-40530	39 - 6
90480-13197	17 - 8		37 - 12	93102-20281	28 - 4	93822-16093	11 - 30		46 - 14		44 - 5
90480-13253	18 - 6		38 - 8	93102-25061	2 - 15	94127-210A1	27 - 25		47 - 3	97702-40530	39 - 13
90480-14102	4 - 18		38 - 11	93102-26042	11 - 24		28 - 7		47 - 15	97706-40620	40 - 3
	18 - 10	92901-05100	3 - 9	93103-28011	2 - 16	94127-21779	27 - 25	95607-14200	30 - 32		40 - 7
90480-18171	4 - 22	92901-06100	24 - 42	93104-07003	27 - 14		28 - 7	95702-12500	39 - 7		40 - 12
	18 - 5	92901-10200	20 - 5	93104-14004	10 - 27	94141-180A2	30 - 18		39 - 14		40 - 17
90480-24186	17 - 6		27 - 33	93105-47007	27 - 7	94141-18780	30 - 18	95707-06500	6 - 3	98501-03008	25 - 10
90501-02217	3 - 4	92901-12600	20 - 10	93106-26005	30 - 6	94225-21186	27 - 26	95707-08500	21 - 4	98501-04006	37 - 11
90501-05512	31 - 20	92902-04100	5 - 25	93109-08017	12 - 7		28 - 8	95707-10500	21 - 6	98501-04008	38 - 10
	32 - 21	92906-08600	3 - 23	93109-14021	19 - 20	94227-21123	27 - 26	95707-12500	39 - 7	98501-04010	39 - 5
	33 - 21	92907-03100	4 - 5	93210-07100	3 - 24		28 - 8		39 - 14	98501-04014	37 - 7
90501-10245	35 - 9	92907-04600	33 - 27	93210-11073	7 - 7	94235-18085	30 - 19		40 - 9		38 - 7
90501-10312	47 - 6	92907-05100	44 - 11	93210-14104	12 - 8	94241-18153	30 - 19		40 - 20	98501-04030	37 - 9
90501-10459	9 - 12		47 - 17		27 - 37	94325-21117	27 - 27	95807-06010	21 - 17	98501-04032	37 - 9
90501-20568	10 - 10	92907-05200	44 - 12	93210-18023	2 - 17		28 - 9		21 - 22	98501-06012	24 - 41
90506-08155	14 - 2	92907-05600	19 - 16	93210-21190	8 - 11	94330-18087	30 - 20		22 - 20	98502-04012	39 - 12
90506-09156	13 - 15		22 - 17	93306-20205	28 - 2	94330-21084	27 - 27		25 - 7	98502-04016	5 - 24
90506-15260	27 - 10	92907-06100	4 - 24	93306-20212	30 - 5		28 - 9		49 - 2	98506-05025	45 - 18
	30 - 10		44 - 19	93306-20529	2 - 13	94340-18065	30 - 20	95807-06012	21 - 19	98506-05030	45 - 19
90507-29042	35 - 13		45 - 7		2 - 14	94416-21006	27 - 23		26 - 4	98507-03008	4 - 4
90508-20023	35 - 18		45 - 16	93306-30101	27 - 2	94416-21007	28 - 5	95807-06045	41 - 15	98507-04014	46 - 9
90508-20345	10 - 23		46 - 7	93306-30212	30 - 4	94418-18007	30 - 16	95807-06050	41 - 15		47 - 9
90508-26450	9 - 5		46 - 16	93306-30304	11 - 21	94580-88116	30 - 35	95807-08012	6 - 5	98507-04018	33 - 26
90508-32349	14 - 3	92907-06200	10 - 18	93306-30411	11 - 22	94580-88118	30 - 35		19 - 13	98507-05014	3 - 16
90508-32354	35 - 2		35 - 7	93306-30421	2 - 13	94680-88001	30 - 36	95807-08045	26 - 7	98507-05016	19 - 15
90508-35350	19 - 26	92907-06600	4 - 10		2 - 14	94701-00045	1 - 17	95827-08035	21 - 8		32 - 31

NUMERICAL INDEX
INDICE NUMERICO

PART NO. CODIGO NO.	REF. NO.	PART NO. CODIGO NO.	REF. NO.	PART NO. CODIGO NO.	REF. NO.	PART NO. CODIGO NO.	REF. NO.	PART NO. CODIGO NO.	REF. NO.
98507-05016	33 - 33								
98507-05018	22 - 16								
98507-05020	47 - 16								
98507-05030	46 - 18								
	47 - 22								
98507-05035	19 - 24								
98507-06016	37 - 13								
	38 - 12								
	44 - 17								
98507-06025	8 - 3								
98507-06030	8 - 8								
	8 - 14								
	12 - 9								
98507-06040	8 - 9								
98507-06050	7 - 8								
98507-06060	7 - 9								
98507-06070	7 - 10								
98507-06075	7 - 11								
98707-04012	32 - 30								
	33 - 32								
98707-06012	11 - 26								
98707-06020	15 - 9								
98901-04008	3 - 6								
98907-06008	6 - 8								
	6 - 18								
99001-08600	3 - 21								
99001-10600	14 - 4								
	14 - 7								
	14 - 17								
99009-20400	27 - 18								
99530-10114	7 - 3								
	8 - 7								
99530-14016	1 - 15								
99530-20020	7 - 4								