



**PARTS
CATALOGUE
CATALOGO
DE REPUESTOS**

YZF-R15 (B121) C. SOUTH AMERICA, ANGOLA



1PB12-200S1

()

YZF-R15
CATALOGO DE REPUESTOS
©2014 por Yamaha Motor Co., Ltd.
1ª edición, junio 2014
Todos los derechos reservados.
Toda reproducción o uso no autorizado
sin el consentimiento escrito de
Yamaha Motor Co., Ltd.
quedan expresamente prohibidos
Impreso en Japón.

YZF-R15
PARTS CATALOGUE
©2014 by Yamaha Motor Co., Ltd.
1st edition, June 2014
All rights reserved.
Any reprinting or unauthorized use
without the written permission of
Yamaha Motor Co., Ltd.
is expressly prohibited.
Printed in Japan.

PROLOGO

Este catálogo de repuestos corresponde a las piezas para el o los modelos que figuran en la página de portada. Al formular el pedido de repuestos, se ruega citar este catálogo y especificar correctamente el número y el nombre de las piezas.

1. Las modificaciones y agregados que se hayan realizado después de la edición de este Catálogo de Repuestos, serán anunciados en las Informaciones de Recambios. Es recomendable que se hagan las correcciones necesarias en el Catálogo de Repuestos de acuerdo con las Informaciones de Recambios.

2. Abreviaciones

En este. Catálogo de Repuestos se emplean las siguientes abreviaciones.

“UR” Usar el número de partes especificado

“UN” Usar la cantidad necesaria

“AP” Piezas sustitutivas

“LM” Fabricación local (Hay que pedir los repuestos en las cercanías)

“F#” N° de bastidor (N° aplicable a la máquina)

“O/S” Sobredimensionado

3. La cantidad de componentes para el montaje

- Los componentes, suministrados como conjunto, se describen con un punto (.) que precede al nombre del parte como se indica a continuación.
- La numeración que aparece a la derecha de cada descripción indica la cantidad de partes por cada unidad de conjunto.

CODIGO N°	DESCRIPCION	CANT.	OBSERVACIONES
2F5-83310-60	ENSAMBLAJE DE LA LUZ	2	
115-83311-60	.BOMBILLA (6V-18W)	1	

4. Los colores de los componentes se indican como sigue en la columna de “OBSERVACIONES”.

CODIGO N°	DESCRIPCION	CANT.	OBSERVACIONES
2N4-24110-00-X5	COMP. DEL TANQUE	2	MXR
3J1-24240-10	.GRAFICO, DEL TANQUE	1	PARA MXR

5. Debe tenerse en cuenta que las ilustraciones sirven como guía para la búsqueda de los números de partes y no deben usarse para el montaje. Durante el montaje, se recomienda usar el manual de taller correspondiente.

6. EL asterisco (*) antes del número de referencia indica los elementos modificados después de la primera edición.

FOREWORD

This Parts Catalogue is related to the parts for the model(s) on the cover page. When you are ordering replacement parts, please refer to this Parts Catalogue and quote both part numbers and part names correctly.

1. Modifications or additions which have been made after the issue of the Parts Catalogue will be announced in the Parts News.

It is advisable that you make the necessary corrections to the Parts Catalogue according to the Parts News.

2. Abbreviations

The following abbreviations are used in this Parts Catalogue.

“UR” Use specified parts number.

“UN” Use as many as needed.

“AP” Alternate Parts

“LM” Locally Made (Parts need to be ordered locally)

“F#” Frame No. (Applicable machine No.)

“O/S” Over Size

3. The number of components for assembly

- Parts, which are to be supplied in an assembly, are listed with a dot (.) in front of the part name as shown below.
- The numeral appearing to the right of each component part indicates the quantity of parts for each assembly unit.

PART NO.	DESCRIPTION	Q'TY	REMARKS
2F5-83310-60	FRONT FLASHER LIGHT ASSY	2	
115-83311-60	.BULB (6V-18W)	1	

4. Applicable colours of graphics are represented in the “REMARKS” as shown below.

PART NO.	DESCRIPTION	Q'TY	REMARKS
2N4-24110-00-X5	FUEL TANK COMP.	2	MXR
3J1-24240-10	.GRAPHIC, FUEL TANK	1	FOR MXR

5. Note that the illustrations for reference in finding parts numbers are not to be used for assembling. When assembling, please use the applicable service manual.

6. The asterisk (*) before a reference number indicates modified items after the first edition.

PROLOGO

7. Números de serie

Nº de Serie del bastidor

Nº de Serie del motor

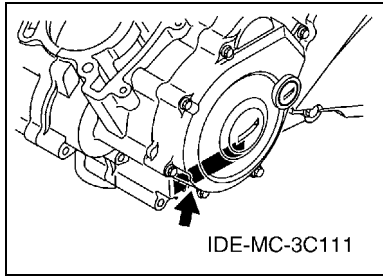
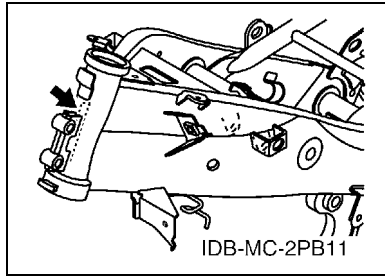

8. Códigos de color aplicables (El símbolo (*) muestra el color de modelo.)

Abreviatura	Nombre de color	Código de color
BWC1(*)	BLUISH WHITE COCKTAIL 1	0390
DBNM8(*)	DARK BLUISH GRAY METALLIC 8	0919
DPBMY	DEEP PURPLISH BLUE METALLIC Y	1115
S3	SILVER 3	0791
SMX	BLACK METALLIC X	0903
VRC1(*)	VIVID RED COCKTAIL 1	0121
YB	YAMAHA BLACK	0033

9. Nº de serie inicial aplicable

Nº de Serie del bastidor

Nº de serie	Nombre de la columna de cantidades	Código de Modelo

Nº de Serie del motor

Nº de serie	Nombre de la columna de cantidades	Código de Modelo

FOREWORD

7. Applicable Serial No.

Frame Serial No.

Engine Serial No.

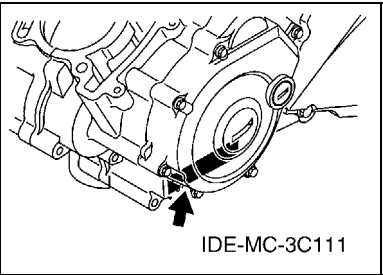
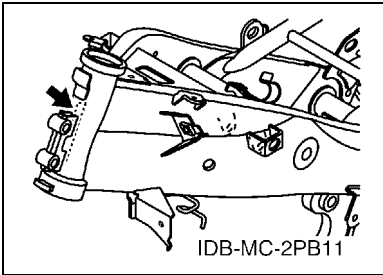

8. Applicable Colour Code (The (*) mark shows Model colour.)

Abbreviation	Colour Name	Colour Code
BWC1(*)	BLUISH WHITE COCKTAIL 1	0390
DBNM8(*)	DARK BLUISH GRAY METALLIC 8	0919
DPBMY	DEEP PURPLISH BLUE METALLIC Y	1115
S3	SILVER 3	0791
SMX	BLACK METALLIC X	0903
VRC1(*)	VIVID RED COCKTAIL 1	0121
YB	YAMAHA BLACK	0033

9. Applicable Starting Serial No.

Frame Serial No.

Serial No.	Name Of Q'ty Column	Model Code

Engine Serial No.

Serial No.	Name Of Q'ty Column	Model Code

CONTENIDO

MOTOR

CULATA DE CILINDRO	1
CIGUENAL & PISTON	2
VALVULA	3
ARBOL DE LEVAS & CADENA	4
BOMBA DE AGUA	5
RADIADOR & MANGUERA	6
BOMBA DE ACEITE	7
ADMISION	8
DESCARGA	10
CARTER	11
CUBIERTA DE CARTER 1	12
EMBRAGUE DEL ARRANQUE	13
EMBRAGUE	14
TRANSMISION	15
LEVA DE CAMBIO & HORQUILLA	17
EJE DE CAMBIO & PEDAL	18

SHASIS

CUADRO	19
GUARDABARRO	20
CUBIERTA LATERAL	21
BRAZO TRASERO & SUSPENSION	23
DIRECCION	24
HORQUILLA DELANTERA	25
DEPOSITO DE COMBUSTIBLE	27
ASIENTO	29
RUEDA DELANTERA	30
CALIBRE FRENO DELANTERA	31
RUEDA TRASERA	32
CALIBRE FRENO TRASERA	34
MANILLAR & CABLE	35
CILINDRO MAESTRO DELANTERO	36
SOPORTE & APOYAPIE	37
CILINDRO MAESTRO TRASERO	39
PATA PROTEGIDA	40
PARABRISAS	41
GENERADOR	44
MOTOR DE ARRANQUE	45
LUZ DE DESTELLADOR	46
MEDIDOR	48
FARO DELANTERO	49

LUZ DE COLA	50
INTERRUPTOR DE MANILLAR&PALANC	51
EQUIPO ELECTRICO 1	52
EQUIPO ELECTRICO 2	53

INDICE

INDICE NUMERICO	55
-----------------------	----

CONTENTS

ENGINE

CYLINDER HEAD	1
CRANKSHAFT & PISTON	2
VALVE	3
CAMSHAFT & CHAIN	4
WATER PUMP	5
RADIATOR & HOSE	6
OIL PUMP	7
INTAKE	8
EXHAUST	10
CRANKCASE	11
CRANKCASE COVER 1	12
STARTER CLUTCH	13
CLUTCH	14
TRANSMISSION	15
SHIFT CAM & FORK	17
SHIFT SHAFT	18

CHASSIS

FRAME	19
FENDER	20
SIDE COVER	21
REAR ARM & SUSPENSION	23
STEERING	24
FRONT FORK	25
FUEL TANK	27
SEAT	29
FRONT WHEEL	30
FRONT BRAKE CALIPER	31
REAR WHEEL	32
REAR BRAKE CALIPER	34
STEERING HANDLE & CABLE	35
FRONT MASTER CYLINDER	36
STAND & FOOTREST	37
REAR MASTER CYLINDER	39
LEG SHIELD	40
WINDSHIELD	41
GENERATOR	44
STARTING MOTOR	45
FLASHER LIGHT	46
METER	48
HEADLIGHT	49

TAILLIGHT	50
HANDLE SWITCH & LEVER	51
ELECTRICAL 1	52
ELECTRICAL 2	53

INDEX

NUMERICAL INDEX	55
-----------------------	----

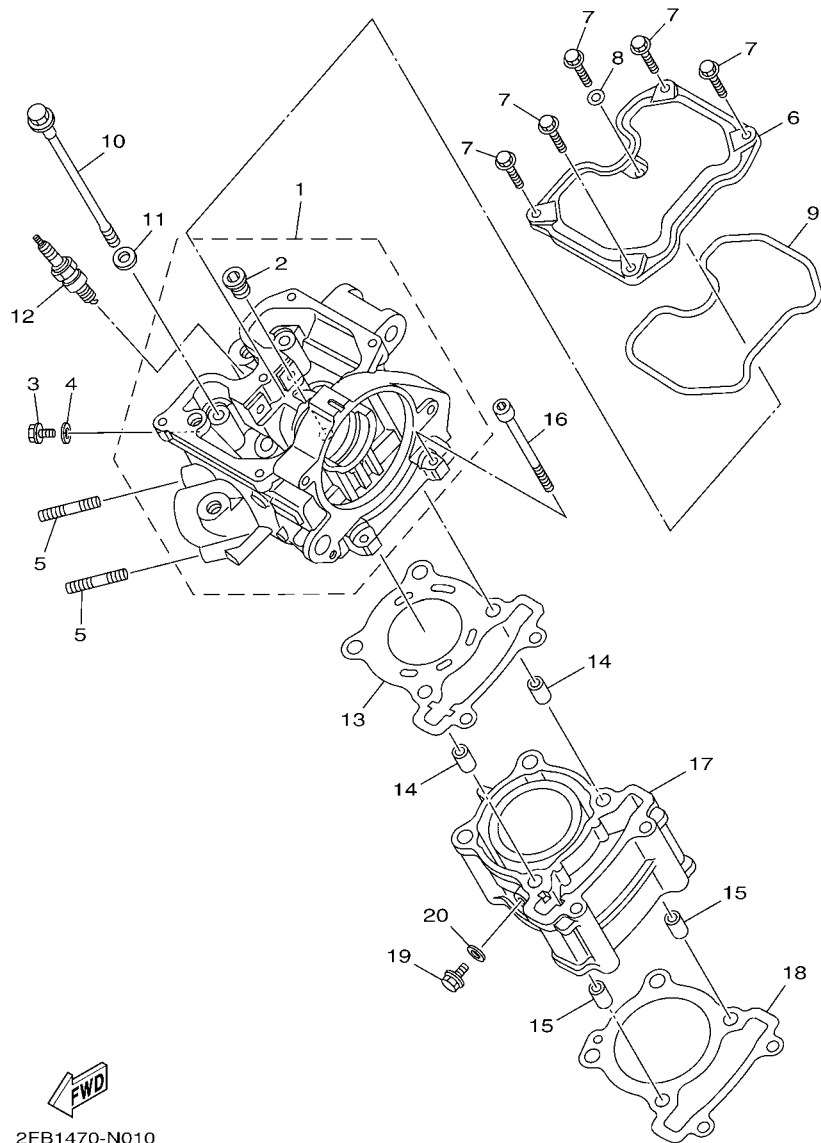
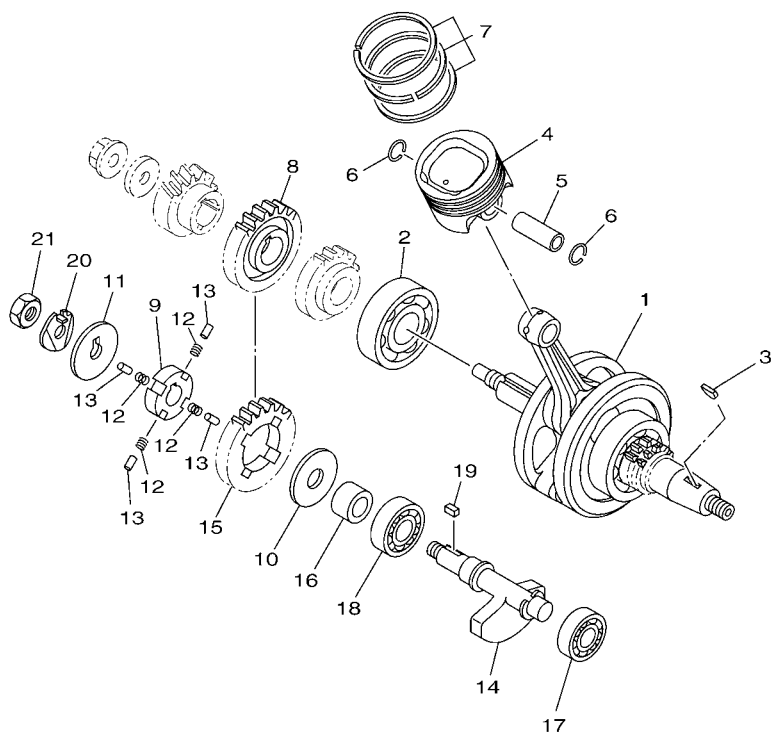

FIG. 1 CULATA DE CILINDRO CYLINDER HEAD

REF. N°	CODIGO N° PART NO.	DESCRIPCION DESCRIPTION	B121				OBSERVACIONES REMARKS
1	2FB-E1102-00	CULATA DE CILINDRO COMPLETA CYLINDER HEAD ASSY	1				
2	90340-12813	.TORNILLO, DE DRENAJE .PLUG, STRAIGHT SCREW	1				
3	95022-06010	PERNO, DE BRIDA BOLT, FLANGE	1				
4	90430-06014	JUNTA GASKET	1				
5	95612-08640	PERNO DE PUNTAL BOLT, STUD	2				
6	1PA-E1191-00	TAPA CULATA DE CILINDRO 1 COVER, CYLINDER HEAD 1	1				
7	95022-06020	PERNO, DE BRIDA BOLT, FLANGE	5				
8	90430-06014	JUNTA GASKET	1				
9	38B-E1193-00	EMPAQUE GASKET, HEAD COVER 1	1				
10	90105-08850	TORNILLO BOLT, FLANGE	4				
11	90201-08609	WASHER, PLATE WASHER, PLATE	4				
12	94703-00318	BUJIA (NGK R CR9E) PLUG, SPARK (NGK R CR9E)	1				
13	1CK-E1181-00	JUNTA, DE CULATA 1 GASKET, CYLINDER HEAD 1	1				
14	91810-14809	PASADOR DE CLAVIJA PIN, DOWEL	2				
15	91810-14809	PASADOR DE CLAVIJA PIN, DOWEL	2				
16	91312-06100	TORNILLO BOLT	2				
17	1PA-E1311-00	CILINDRO 1 CYLINDER 1	1				
18	38B-E1351-00	JUNTA, DE CILINDRO GASKET, CYLINDER	1				
19	95022-06010	PERNO, DE BRIDA BOLT, FLANGE	1				
20	90430-06014	JUNTA GASKET	1				

FIG. 2 CIGUENAL & PISTON

CRANKSHAFT & PISTON



REF. N°	CODIGO N° PART NO.	DESCRIPCION DESCRIPTION	B121				OBSERVACIONES REMARKS
1	1CK-E1400-09	CIGUENAL COMPLETO CRANKSHAFT ASSY	1				
2	93306-305X7	COJINETE BEARING	1				
3	90280-03017	CUNA WOODRUFF KEY, WOODRUFF	1				
4	3C1-E1631-11	PISTON (NORMA) PISTON (STD)	1				
5	38B-E1633-00	PASADOR, PISTON PIN, PISTON	1				
6	93450-16115	SEGURO CIRCLIP	2				
7	1PA-E1603-00	JUEGO DE ANILLOS (NORMA) PISTON RING SET (STD)	1				
8	38B-E1536-10	ENGRANAJE TRACCION GEAR, DRIVE	1				
9	21C-E1496-20	COPA TOPE BOSS, BUFFER	1				
10	90201-15022	ARANDELA PLANA WASHER, PLATE	1				
11	90214-10006	ARANDELA DE POSICION WASHER, CLAW	1				
12	54B-E1476-00	RESORTE SPRING	4				
13	21C-E3362-00	RODILLO ROLLER	4				
14	2FB-E1454-00	PESO 1 WEIGHT 1	1				
15	21C-E1531-01	ENGRANAJE CONTRAPESO GEAR, BALANCE WEIGHT	1				
16	90387-15810	ESPACIADOR COLLAR	1				
17	93306-202YD	COJINETE BEARING	1				
18	93306-203XS	COJINETE BEARING	1				
19	90282-05031	CHAVETA, RECTA KEY, STRAIGHT	1				
20	90215-10284	ARANDELA DE CIERRE WASHER, LOCK	1				
21	90170-10012	TUERCA NUT	1				

2FB1470-N020

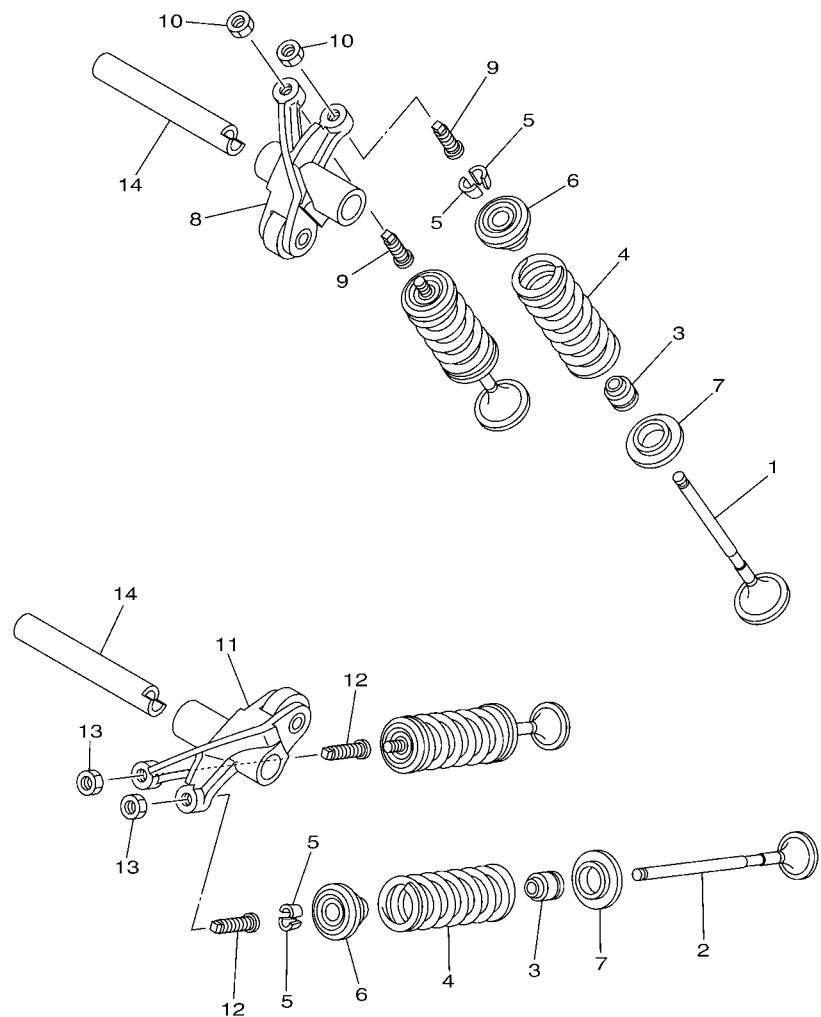

2FB1470-N030

FIG. 3 VALVULA

VALVE

REF. Nº	CODIGO Nº PART NO.	DESCRIPCION DESCRIPTION	B121				OBSERVACIONES REMARKS
1	5YP-E2111-00	VALVULA DE ADMISION VALVE, INTAKE	2				
2	5YP-E2121-00	VALVULA DE ESCAPE VALVE, EXHAUST	2				
3	38B-E2119-00	SELLO DE ACEITE VALVULA SEAL, VALVE STEM	4				
4	38B-E2113-00	RESORTE VALVULA INTERNA SPRING, VALVE INNER	4				
5	1WG-12118-00	SEGURO DE VALVULA LOCK, VALVE SPRING RETAINER	8				
6	1PA-E2117-00	RETEN RESORTE DE VALVULA RETAINER, VALVE SPRING	4				
7	38B-E2126-00	ASIENTO RESORTE DE VALVULA2 SEAT, VALVE SPRING 2	4				
8	38B-E2151-00	BRAZO DE BALANCIN DE VALVULA ARM, VALVE ROCKER	1				
9	2DM-12159-00	TORNILLO DE AJUSTE DE VALVULA SCREW, VALVE ADJUSTING	2				
10	90170-05302	TUERCA NUT	2				
11	38B-E2161-00	BRAZO DE BALANCIN DE VALVULA ARM, VALVE ROCKER 2	1				
12	2DM-12159-00	TORNILLO DE AJUSTE DE VALVULA SCREW, VALVE ADJUSTING	2				
13	90170-05302	TUERCA NUT	2				
14	1CK-E2156-00	EJE DE BALANCIN SHAFT, ROCKER 2	2				

FIG. 4 ARBOL DE LEVAS & CADENA CAMSHAFT & CHAIN

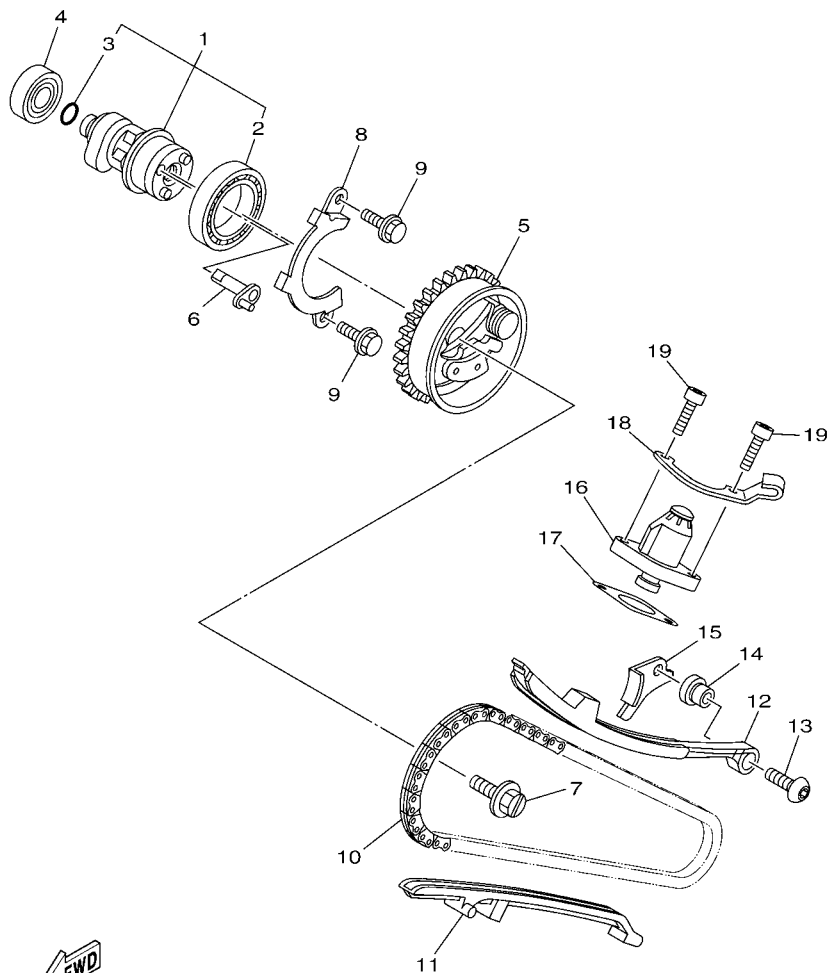



38B1470-H040

REF. Nº	CODIGO Nº PART NO.	DESCRIPCION DESCRIPTION	B121				OBSERVACIONES REMARKS
1	38B-E2170-00	ARBOL DE LEVAS COMPLETO 1 CAMSHAFT ASSY 1	1				
2	93306-906Y0	.COJINETE .BEARING	1				UR
	93306-906Y1	.COJINETE .BEARING	1				UR
3	93210-09809	.ANILLO O .O-RING	1				UR
4	93306-001X7	COJINETE BEARING	1				
5	1PA-E2280-00	EQUIPO DE DESCOMPRESION DECOMPRESSION ASSY	1				
6	2FB-E2288-00	LEVA DE DESCOMPRESION CAM, DECOMPRESSION	1				
7	2FB-E2157-00	PERNO BOLT	1				
8	38B-E111F-00	PLACA PLATE	1				
9	95022-06010	PERNO, DE BRIDA BOLT, FLANGE	2				
10	94568-A8096	CADENA CHAIN	1				
11	38B-E2231-00	TOPE DE GUIA 1 GUIDE, STOPPER 1	1				
12	38B-E2241-00	TOPE DE GUIA 2 GUIDE, STOPPER 2	1				
13	90149-06829	TORNILLO DE REGLAJE SCREW	1				
14	38B-E5598-00	COLLAR COLLAR	1				
15	38B-E2256-00	CUBIERTA DE CADENA COVER, CHAIN	1				
16	38B-E2210-00	TENSOR CADENA DE LEVA TENSIONER ASSY, CAM CHAIN	1				
17	1CK-E2213-00	EMPAQUE DE CAJA TENSOR GASKET, TENSIONER CASE	1				
18	38B-E5441-00	SOSTEN DE CABLE DE EMBRAGUE HOLDER, CLUTCH CABLE	1				
19	91312-06020	TORNILLO BOLT	2				

FIG. 5 BOMBA DE AGUA

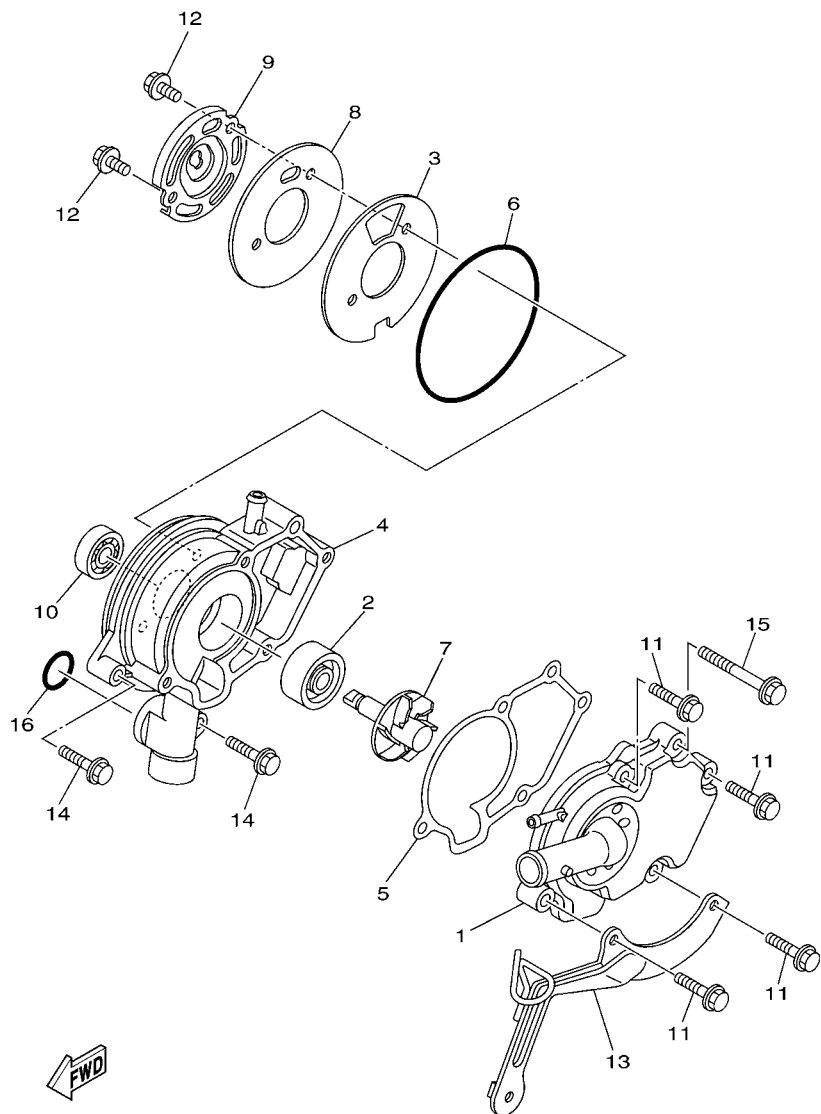
WATER PUMP



3C11460-F050

REF. Nº	CODIGO Nº PART NO.	DESCRIPCION DESCRIPTION	B121				OBSERVACIONES REMARKS
1	38B-E2422-00	CUBIERTA DE CAJA COVER, HOUSING	1				
2	93103-10804	SELLO ACEITE OIL SEAL	1				
3	38B-E2428-00	JUNTA, DE CBTA.CAJA 2 GASKET, HOUSING COVER 2	1				
4	38B-E1185-01	CUBIERTA CULATA CIL.LAT.3 COVER, CYLINDER HEAD SIDE 3	1				
5	38B-E1196-00	EMPAQUE DE CULATA GASKET, CYLINDER HEAD SIDE	1				
6	93210-84802	ANILLO O O-RING	1				
7	38B-E2450-01	EJE IMPULSOR COMPLETO IMPELLER SHAFT ASSY	1				
8	38B-E1951-00	PLACA PLATE	1				
9	38B-E1952-01	PLACA PLATE	1				
10	93306-000Y5	COJINETE BEARING	1				
11	95022-06025	PERNO, DE BRIDA BOLT, FLANGE	4				
12	95022-06012	PERNO, DE BRIDA BOLT, FLANGE	2				
13	38B-E2443-00	APOYO STAY	1				
14	95022-06025	PERNO, DE BRIDA BOLT, FLANGE	2				
15	95022-06050	PERNO, DE BRIDA BOLT, FLANGE	1				
16	93210-19809	ANILLO O O-RING	1				

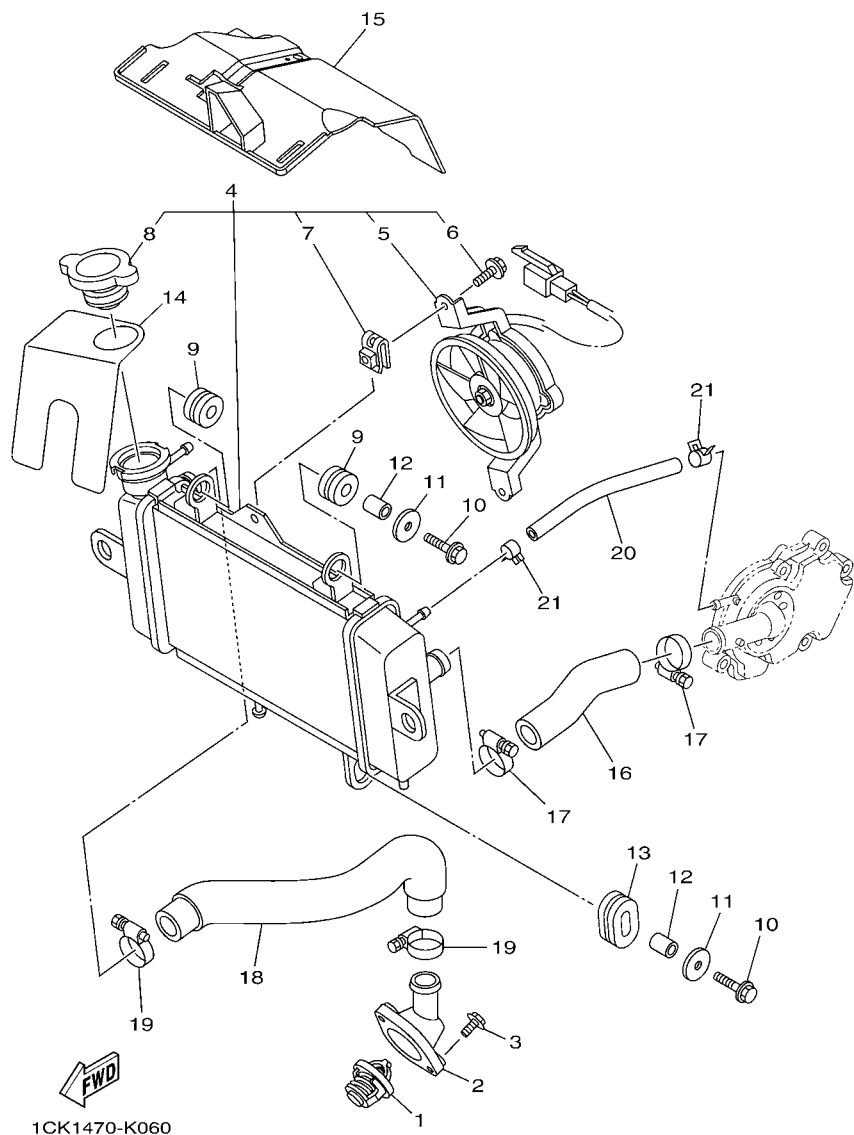
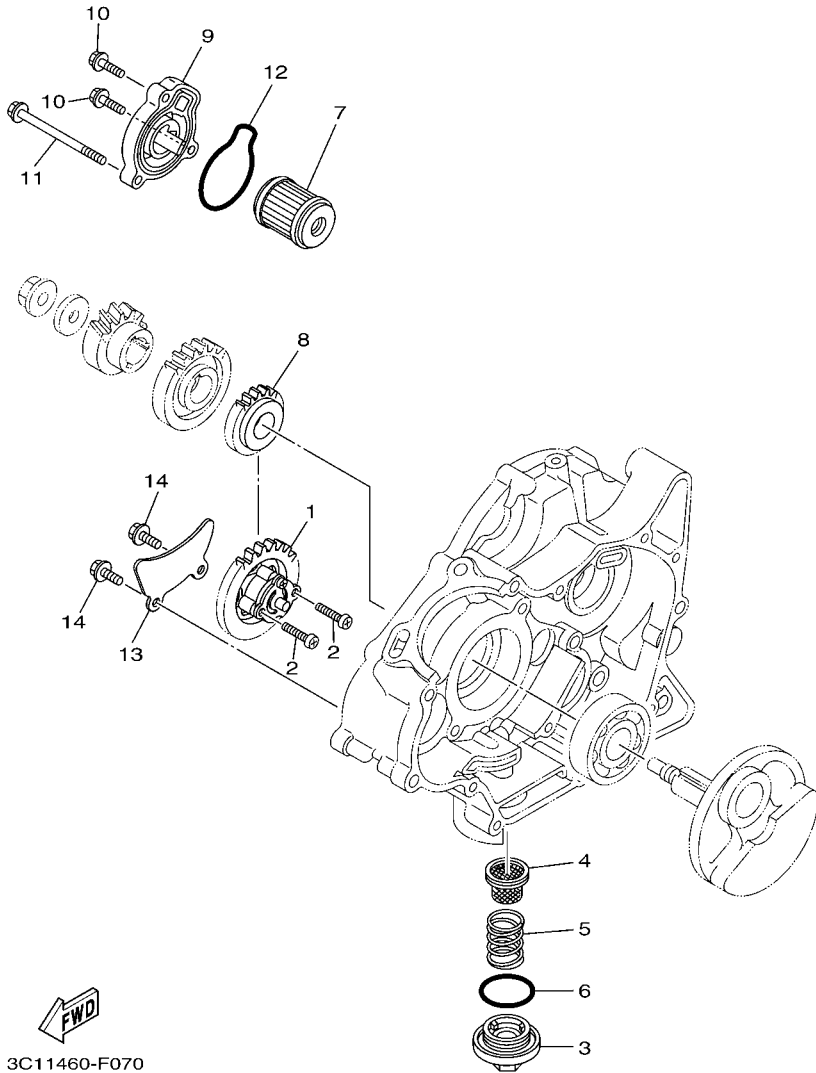

FIG. 6 RADIADOR & MANGUERA RADIATOR & HOSE

REF. Nº	CODIGO Nº PART NO.	DESCRIPCION DESCRIPTION	B121			OBSERVACIONES REMARKS
1	1CK-E2411-00	TERMOSTAT THERMOSTAT	1			
2	38B-E2413-00	CUBIERTA TERMOSTATO COVER, THERMOSTAT	1			
3	95022-06020	PERNO, DE BRIDA BOLT, FLANGE	2			
4	38B-E240A-00	RADIADOR COMPLETO RADIATOR ASSY	1			
5	5YP-E2405-00	.COMPRESOR .BLOWER ASSY	1			
6	5YP-E2675-00	.PERNO, SUJECION VENTILADOR .BOLT, BLOWER HOLDING	2			
7	5YP-E2671-00	.TUERCA 1 .NUT 1	2			
8	5ST-E2590-00	.TAPON, DEL RADIADOR .CAP, RADIATOR	1			
9	90480-15363	TAPON GROMMET	2			
10	95822-06025	TORNILLO DE REBORDE BOLT, FLANGE	2			
11	90201-06072	ARANDELA PLANA WASHER, PLATE	2			
12	90387-064W3	ESPACIADOR COLLAR	2			
13	90480-01803	TAPON GROMMET	1			
14	1CK-E246A-00	CUBIERTA 1 COVER 1	1			
15	20P-E2467-01	CUBIERTA DEL RADIADOR COVER, RADIATOR	1			
16	20P-E2481-00	TUBO 1 PIPE 1	1			
17	90450-27803	BRIDA, MANGUERA HOSE CLAMP ASSY	2			
18	20P-E2482-00	TUBO 2 PIPE 2	1			
19	90450-27803	BRIDA, MANGUERA HOSE CLAMP ASSY	2			
20	90445-12804	TUBO HOSE	1			
21	90467-10808	PRESILLA CLIP	2			



3C11460-F070

FIG. 7 BOMBA DE ACEITE

OIL PUMP

REF. N°	CODIGO N° PART NO.	DESCRIPCION DESCRIPTION	B121				OBSERVACIONES REMARKS
1	38B-E3300-01	BOMBA DE ACEITE COMPLETA OIL PUMP ASSY	1				
2	98502-05025	TORNILLO SCREW, PAN HEAD	2				
3	38B-E5351-00	TAPON DE DRENAJE PLUG, DRAIN	1				
4	38B-E3411-00	FILTRO DE ACEITE STRAINER, OIL	1				
5	90501-18576	RESORTE DE COMPRESION SPRING, COMPRESSION	1				
6	93210-34805	ANILLO O O-RING	1				
7	38B-E3440-00	ELEMENTO FILTRO DE ACEITE ELEMENT ASSY, OIL CLEANER	1				
8	38B-E3324-00	ENGRANAJE TRACC. DE BOMBA GEAR, PUMP DRIVE	1				
9	38B-E3447-00	TAPA DEL ELEMENTO COVER, OIL ELEMENT	1				
10	95022-06020	PERNO, DE BRIDA BOLT, FLANGE	2				
11	95022-06080	PERNO, DE BRIDA BOLT, FLANGE	1				
12	93210-54806	ANILLO O O-RING	1				
13	38B-E3327-00	CUBIERTA ENGRANAJE DE BOMBA COVER, PUMP GEAR	1				
14	95022-06012	PERNO, DE BRIDA BOLT, FLANGE	2				

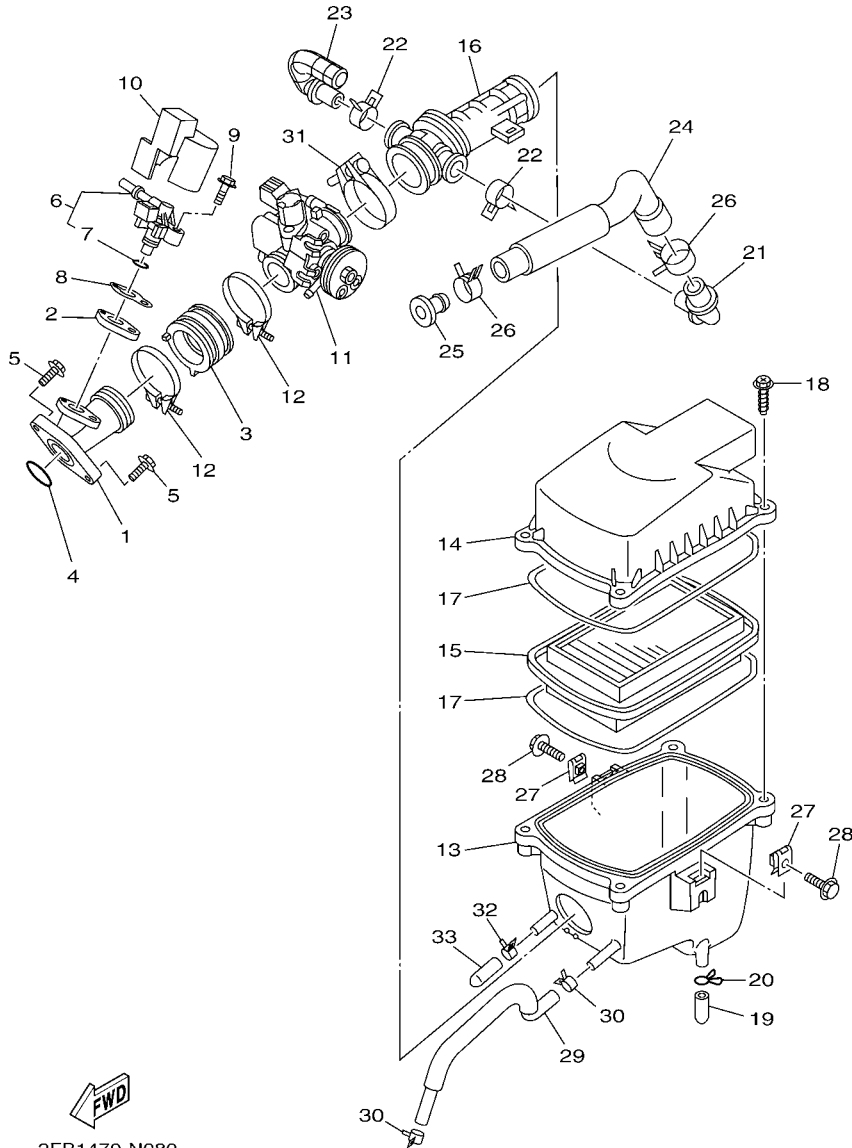

2FB1470-N080

FIG. 8 ADMISION

INTAKE

REF. N°	CODIGO N° PART NO.	DESCRIPCION DESCRIPTION	B121			OBSERVACIONES REMARKS
1	2FB-E3585-00	MULTIPLE MANIFOLD	1			
2	2FB-E3556-00	EMPAQUE GASKET, MANIFOLD	1			
3	2FB-E3635-00	JUNTA DE ADMISION 1 JOINT, INTAKE 1	1			
4	93210-32807	ANILLO O O-RING	1			
5	95022-06020	PERNO, DE BRIDA BOLT, FLANGE	2			
6	5D7-E3770-00	INYECTOR INJECTOR ASSY	1			
7	5CA-E4147-00	.ANILLO O .O-RING	1			
8	2FB-E3557-00	EMPAQUE GASKET	1			
9	95812-06030	TORNILLO DE REBORDE BOLT, FLANGE	1			
10	2FB-E3767-00	TAPA DE INYECTOR CAP, INJECTOR	1			
11	B12-E3750-00	CAJA DE ACCELERADOR COMPL. THROTTLE BODY ASSY	1			
12	90450-48805	BRIDA, MANGUERA HOSE CLAMP ASSY	2			
13	20P-E4411-00	CAJA FILTRO DEL AIRE 1 CASE, AIR CLEANER 1	1			
14	20P-E4412-00	TAPA CAJA DEL FILTRO 1 CAP, CLEANER CASE 1	1			
15	20P-E4450-00	ELEMENTO COMP.FILTRO DE AIRE ELEMENT ASSY, AIR CLEANER	1			
16	20P-E4453-01	UNION DEL FILTRO DEL AIRE 1 JOINT, AIR CLEANER 1	1			
17	3C1-E4452-00	SELLO SEAL	2			
18	90163-05803	TORNILLO ROSCA HEMBRA SCREW, TAPPING	4			
19	20P-E443E-00	TUBO, DRENAJE PIPE, DRAIN	1			
20	90467-12800	PRESILLA CLIP	1			
21	20P-E4485-00	TUBO DE UNION PIPE, JOINT	1			
22	90467-20050	PRESILLA CLIP	2			
23	20P-E4419-00	TUBO PIPE	1			
24	20P-E441J-00	TUBO PIPE, SILENCER	1			
25	90338-16008	TAPON PLUG	1			
26	90467-23059	PRESILLA CLIP	2			
27	90183-06822	TUERCA DE RESORTE NUT, SPRING	2			

FIG. 8 ADMISION

INTAKE

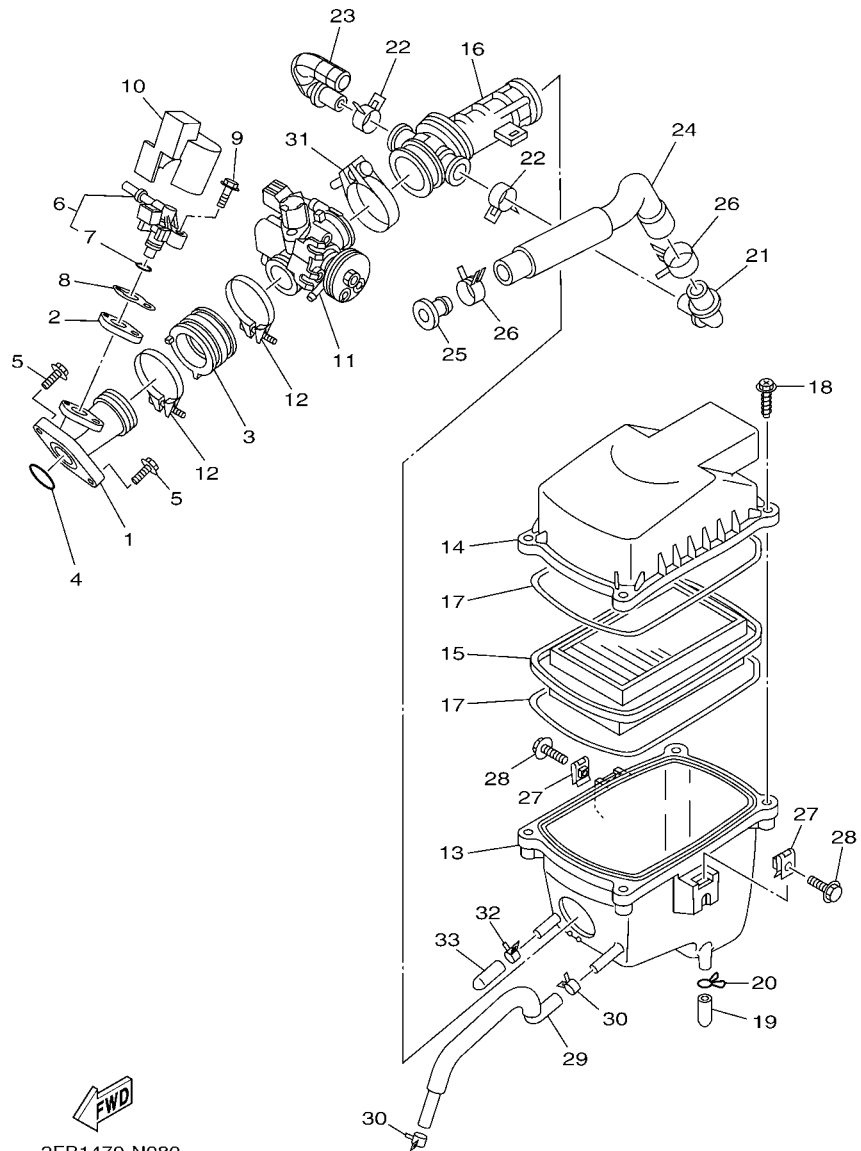

2FB1470-N080

REF. Nº	CODIGO Nº PART NO.	DESCRIPCION DESCRIPTION	B121			OBSERVACIONES REMARKS
28	90119-06209	TORNILLO CON ARANDELA BOLT, WITH WASHER	2			
29	2FB-E1166-00	TUBO RESPIRADERO 1 PIPE, BREATHER 1	1			
30	90467-13816	PRESILLA CLIP	2			
31	90450-39806	BRIDA, MANGUERA HOSE CLAMP ASSY	1			
32	90467-13802	PRESILLA CLIP	1			
33	2FB-E443H-00	TUBO, DRENAJE 3 PIPE, DRAIN 3	1			

FIG. 9 DESCARGA

EXHAUST

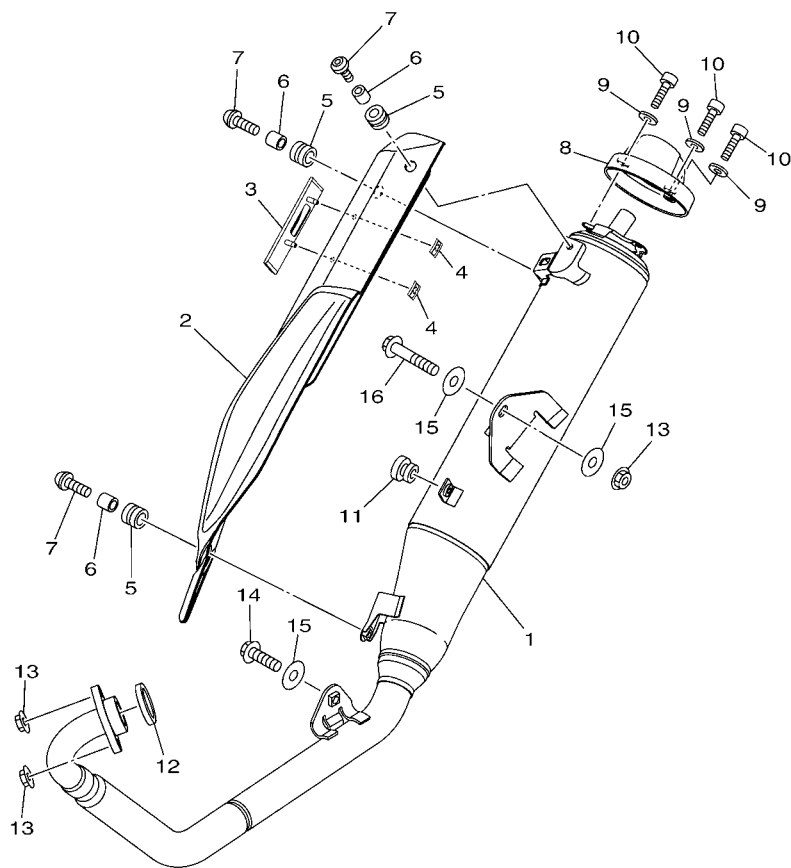



2FB1470-N090

REF. N°	CODIGO N° PART NO.	DESCRIPCION DESCRIPTION	B121				OBSERVACIONES REMARKS
1	2FB-E4703-00	SILENCIADOR COMPL. 1 MUFFLER COMP. 1	1				
2	1CK-E4718-00	PROTECTOR DE SILENCIADOR 1 PROTECTOR, MUFFLER 1	1				
3	1CK-E4728-00	PROTECTOR DE SILENCIADOR PROTECTOR, MUFFLER 2	1				
4	90183-05M01	TUERCA DE RESORTE NUT, SPRING	2				
5	90480-12581	TAPON GROMMET	3				
6	90387-06023	ESPACIADOR COLLAR	3				
7	90111-06826	TORNILLO BOLT, HEX. SOCKET BUTTON	3				
8	1CK-E4799-00	TAPA CAP	1				
9	92990-06200	ARANDELA PLANA WASHER, PLAIN	3				
10	91380-06016	PERNO BOLT	3				
11	90480-10805	TAPON GROMMET	1				
12	21C-E4613-00	JUNTA, TUBO DE ESCAPE GASKET, EXHAUST PIPE	1				
13	95702-08500	TUERCA DE BRIDA NUT, FLANGE	3				
14	95812-08016	TORNILLO DE REBORDE BOLT, FLANGE	1				
15	90201-08612	ARANDELA PLANA WASHER, PLATE	3				
16	95812-08040	TORNILLO DE REBORDE BOLT, FLANGE	1				

FIG. 10 CARTER

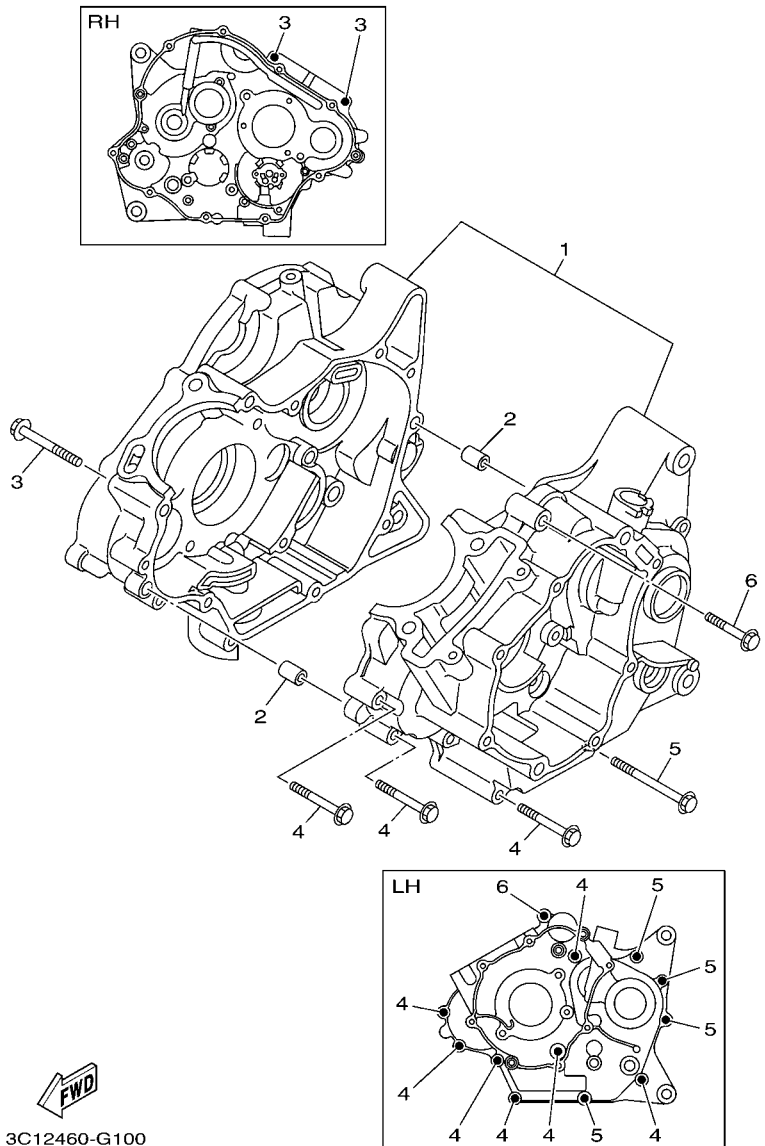
CRANKCASE



3C12460-G100

REF. N°	CODIGO N° PART NO.	DESCRIPCION DESCRIPTION	B121			OBSERVACIONES REMARKS
1	2FB-E5150-00	CARTER COMPLETO CRANKCASE ASSY	1			
2	91810-14809	PASADOR DE CLAVIJA PIN, DOWEL	2			
3	95022-06055	PERNO, DE BRIDA BOLT, FLANGE	2			
4	95022-06045	PERNO, DE BRIDA BOLT, FLANGE	7			
5	95022-06070	PERNO, DE BRIDA BOLT, FLANGE	4			
6	95022-06040	PERNO, DE BRIDA BOLT, FLANGE	1			
<hr style="border-top: 1px dashed black;"/>						
<hr style="border-top: 1px dashed black;"/>						
<hr style="border-top: 1px dashed black;"/>						
<hr style="border-top: 1px dashed black;"/>						
<hr style="border-top: 1px dashed black;"/>						
<hr style="border-top: 1px dashed black;"/>						
<hr style="border-top: 1px dashed black;"/>						
<hr style="border-top: 1px dashed black;"/>						

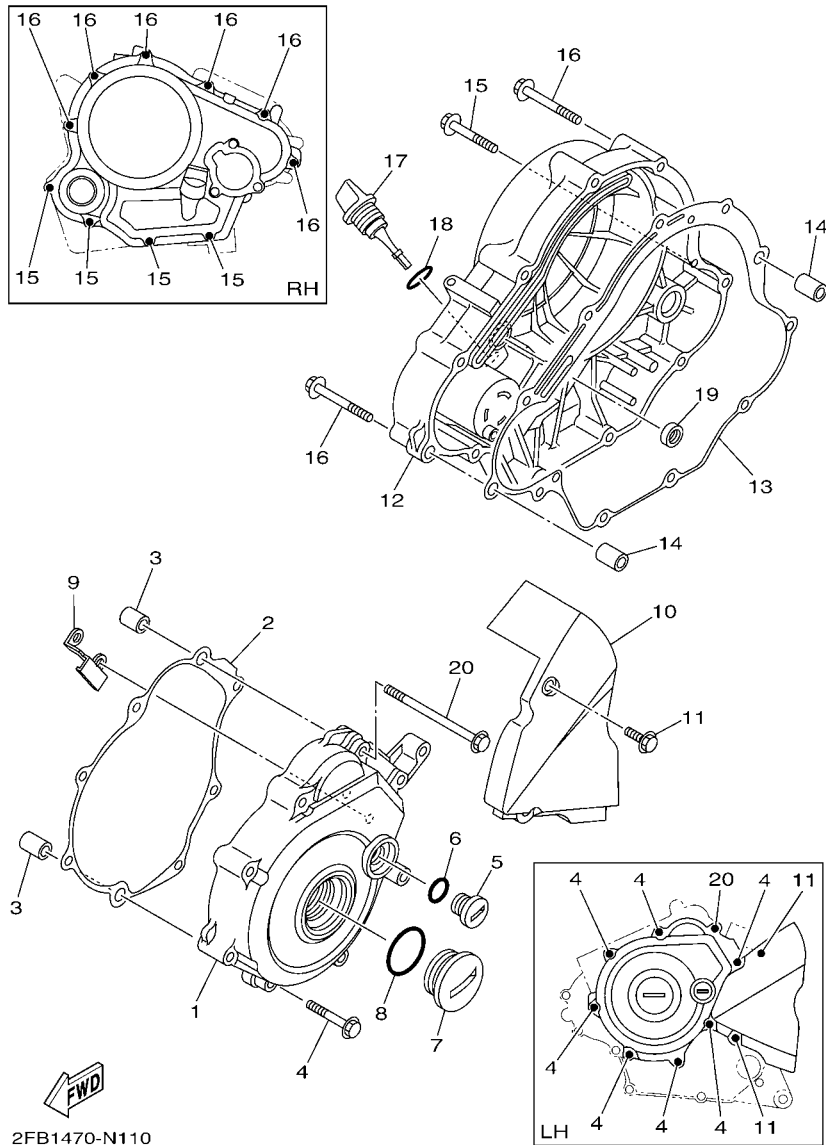

2FB1470-N110

FIG. 11 CUBIERTA DE CARTER 1

CRANKCASE COVER 1

REF. Nº	CODIGO Nº PART NO.	DESCRIPCION DESCRIPTION	B121				OBSERVACIONES REMARKS
1	2FB-E5411-00	CUBIERTA DE CARTER 1 COVER, CRANKCASE 1	1				
2	2FB-E5451-00	EMPAQ DE CUBIERTA DE CARTER GASKET, CRANKCASE COVER 1	1				
3	91810-14809	PASADOR DE CLAVIJA PIN, DOWEL	2				
4	95022-06040	PERNO, DE BRIDA BOLT, FLANGE	7				
5	90340-14824	TORNILLO, DE DRENAJE PLUG, STRAIGHT SCREW	1				
6	93210-14812	ANILLO O O-RING	1				
7	90340-32823	TORNILLO, DE DRENAJE PLUG, STRAIGHT SCREW	1				
8	93210-32813	ANILLO O O-RING	1				
9	2FB-E5113-00	PLACA PLATE	1				
10	38B-E5418-00	CUBIERTA CAJA DE CADENA COVER, CHAIN CASE	1				
11	95022-06016	PERNO, DE BRIDA BOLT, FLANGE	2				
12	1CK-E5421-00	TAPA DE CARTER DERECHA COVER, CRANKCASE 2	1				
13	2FB-E5461-00	JUNTA TAPA CARTER DERECHO 2 GASKET, CRANKCASE COVER 2	1				
14	91810-14809	PASADOR DE CLAVIJA PIN, DOWEL	2				
15	95022-06040	PERNO, DE BRIDA BOLT, FLANGE	4				
16	95022-06050	PERNO, DE BRIDA BOLT, FLANGE	6				
17	38B-E5362-00	TAPON DEL NIVEL DE ACEITE PLUG, OIL LEVEL	1				
18	93210-19809	ANILLO O O-RING	1				
19	93101-10805	SELLO ACEITE OIL SEAL	1				
20	95022-06090	PERNO, DE BRIDA BOLT, FLANGE	1				

FIG. 12 EMBRAGUE DEL ARRANQUE STARTER CLUTCH

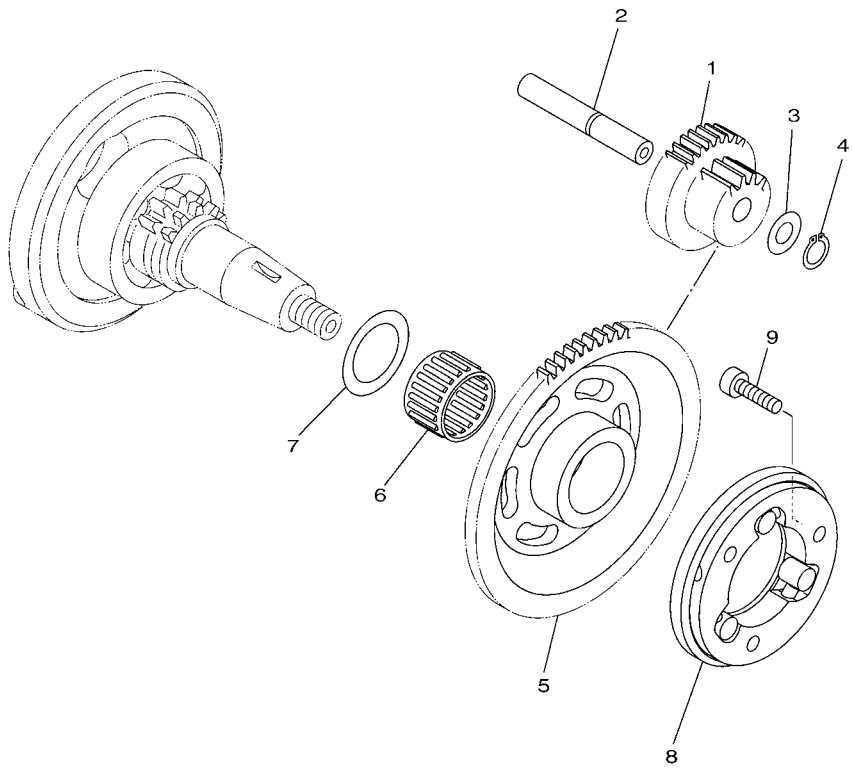

REF. Nº	CODIGO Nº PART NO.	DESCRIPCION DESCRIPTION	B121				OBSERVACIONES REMARKS
1	1CK-E5514-00	ENGRANAJE 2 GEAR 2	1				
2	38B-E5521-00	EJE 1 SHAFT 1	1				
3	90201-105E8	ARANDELA PLANA WASHER, PLATE	1				
4	99009-10400	PRESILLA REDONDA CIRCLIP	1				
5	38B-E5524-10	RUEDA DE ARRANQUE WHEEL, STARTER	1				
6	93310-325X3	COJINETE DE RODILLOS BEARING	1				
7	90201-25290	ARANDELA PLANA WASHER, PLATE	1				
8	21C-E5580-10	ENSAMBLE EXT. EMBRAGUE ARRANQUE STARTER CLUTCH OUTER ASSY	1				
9	91312-06020	TORNILLO BOLT	3				

38B1470-H120

FIG. 13 EMBRAGUE

CLUTCH

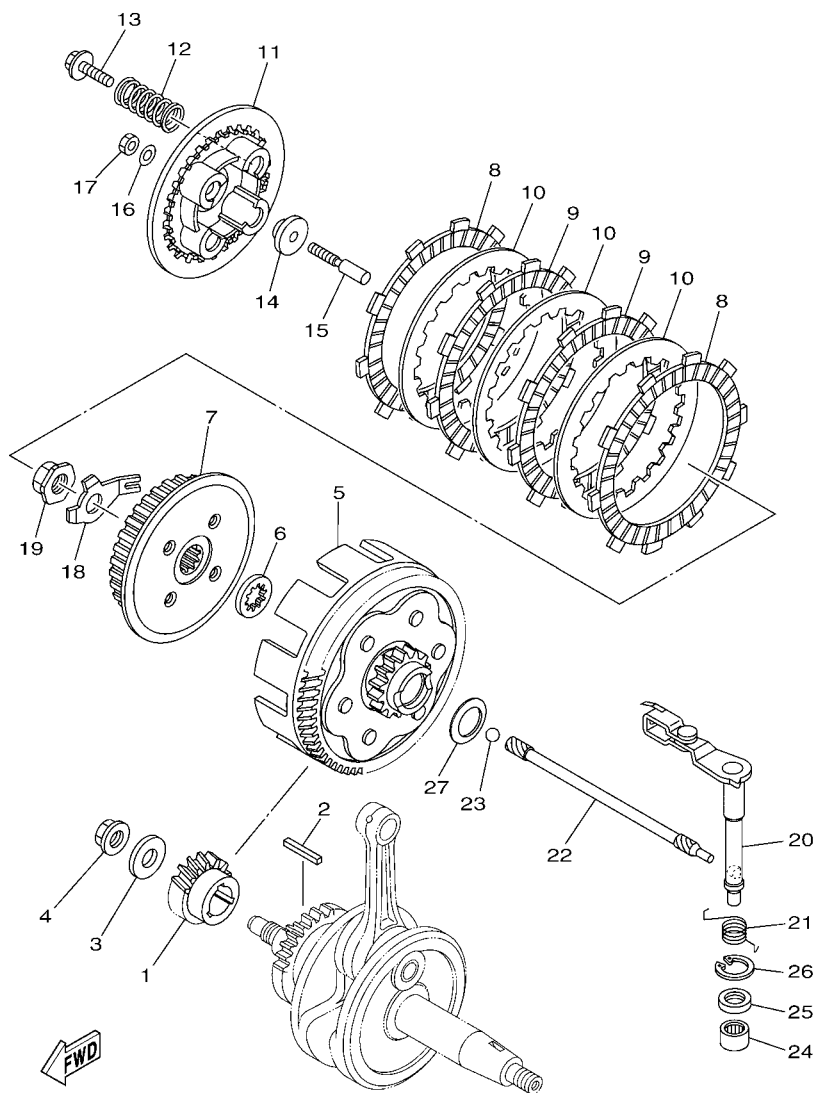

38B1470-H130

REF. Nº	CODIGO Nº PART NO.	DESCRIPCION DESCRIPTION	B121				OBSERVACIONES REMARKS
1	38B-E6111-00	ENGRANAJE TRACC.PRIMARIA GEAR, PRIMARY DRIVE	1				
2	38B-E6193-00	CHAVETA DE AGUJA KEY, FEATHER	1				
3	90201-12019	ARANDELA PLANA WASHER, PLATE	1				
4	90179-12802	TUERCA NUT	1				
5	1CK-E6150-00	CAMPANA DE EMBRAGUE PRIMARY DRIVEN GEAR COMP.	1				
6	21C-E6154-00	ARANDELA, DE EMPUJE 1 PLATE, THRUST 1	1				
7	21C-E6371-00	CUBO, DE EMBRAGUE BOSS, CLUTCH	1				
8	54B-E6321-00	PLACA DE FRICCION PLATE, FRICTION	2				
9	21C-E6331-00	DISCO, DE FRICCION 2 PLATE, FRICTION 2	2				
10	21C-E6324-00	PLACA DE EMBRAGUE PLATE, CLUTCH 1	3				
11	54B-E6351-00	PLATO DE PRESION PLATE, PRESSURE 1	1				
12	21C-E6333-00	RESORTE DE EMBRAGUE 1 SPRING, CLUTCH 1	4				
13	21C-E6337-00	TORNILLO DE RESORTE SCREW, SPRING	4				
14	21C-E6358-00	PLACA DE EMPUJE PLATE, PUSH	1				
15	21C-E6356-01	VARILLA DE EMPUJE 1 ROD, PUSH 1	1				
16	54B-E6144-00	ARANDELA WASHER	1				
17	3C1-E6344-00	TUERCA DE AJUSTE NUT, ADJUSTING	1				
18	21C-E6135-10	ARANDELA DE CIERRE WASHER, LOCK	1				
19	90179-14001	TUERCA NUT	1				
20	38B-E6380-01	LEVA DE EMPUJE COMPLETA PUSH LEVER ASSY	1				
21	1CK-E6345-00	RESORTE DE RETORNO SPRING, RETURN	1				
22	38B-E6357-01	VARILLA DE EMPUJE 2 ROD, PUSH 2	1				
23	93505-16844	BOLA BALL	1				
24	93315-112Y9	COJINETE DE RODILLOS BEARING	1				
25	93102-12877	SELLO ACEITE OIL SEAL	1				
26	99009-20500	PRESILLA REDONDA CIRCLIP	1				
27	90208-20003	ARANDELA DE RESORTE CONICO WASHER, CONICAL SPRING	1				

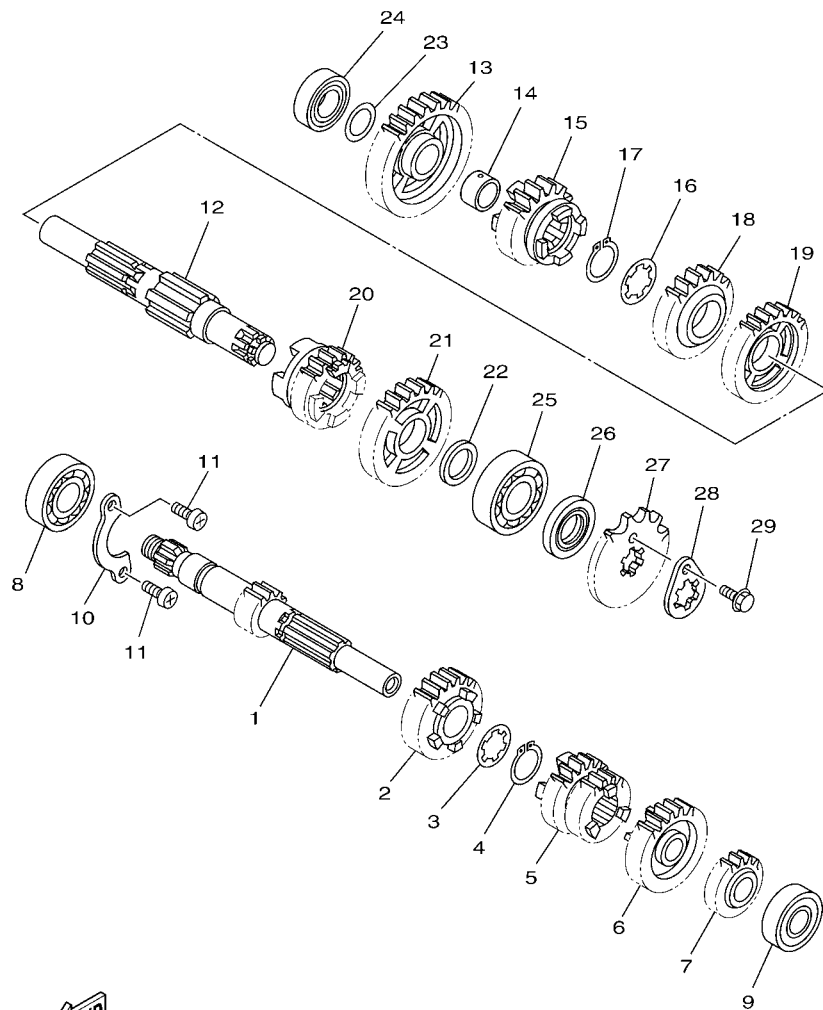

1CK1470-K140

FIG. 14 TRANSMISION

TRANSMISION

REF. N°	CODIGO N° PART NO.	DESCRIPCION DESCRIPTION	B121				OBSERVACIONES REMARKS
1	38B-E7411-01	EJE PRIMARIO (12T) AXLE, MAIN (12T)	1				
2	38B-E7151-00	ENGRANAJE PINON DE 5TA (21T) GEAR, 5TH PINION (21T)	1				
3	90209-17285	ARANDELA DE SEPARACION WASHER	1				
4	93410-20809	SEGURO CIRCLIP	1				
5	38B-E7131-00	ENGRANAJE PINON DE 3RA(22/21T) GEAR, 3RD PINION (22T/21T)	1				
6	38B-E7161-00	ENGRANAJE PINON 6TA (25T) GEAR, 6TH PINION (25T)	1				
7	38B-E7121-00	ENGRANAJE DE PINON DE 2DA(16T) GEAR, 2ND PINION (16T)	1				
8	93306-004XX	COJINETE BEARING	1				
9	93306-202YE	COJINETE BEARING	1				
10	38B-E7471-00	PLACA, DE CUBIERTA PLATE, COVER	1				
11	98512-06012	TORNILLO SCREW, PAN HEAD	2				
12	1CK-E7402-00	EJE DE TRACCION COMPLETO DRIVE AXLE ASSY	1				
13	38B-E7211-00	ENGRANAJE RUEDA DE 1 RA (34T) GEAR, 1ST WHEEL (34T)	1				
14	38B-E7258-00	COLLAR 1 COLLAR 1	1				
15	38B-E7251-00	ENGRANAJE RUEDA DE 5TA (22T) GEAR, 5TH WHEEL (22T)	1				
16	90209-18208	ARANDELA DE SEPARACION WASHER	1				
17	93410-22039	SEGURO CIRCLIP	1				
18	38B-E7241-00	ENGRANAJE DE RUEDA 4TA (24T) GEAR, 4TH WHEEL (24T)	1				
19	38B-E7231-00	ENGRANAJE RUEDA DE 3RA (30T) GEAR, 3RD WHEEL (30T)	1				
20	38B-E7261-00	ENGRANAJE RUEDA DE 6TA (21T) GEAR, 6TH WHEEL (21T)	1				
21	38B-E7221-00	ENGRANAJE RUEDA DE 2DA (30T) GEAR, 2ND WHEEL (30T)	1				
22	90201-20814	ARANDELA PLANA WASHER, PLATE	1				
23	90201-173F4	ARANDELA PLANA WASHER, PLATE	1				
24	93306-003YN	COJINETE BEARING	1				
25	93306-204Y6	COJINETE BEARING	1				
26	93102-20806	SELLO ACEITE OIL SEAL	1				
27	93822-15808	CORONA (15T) SPROCKET, DRIVE (15T)	1				

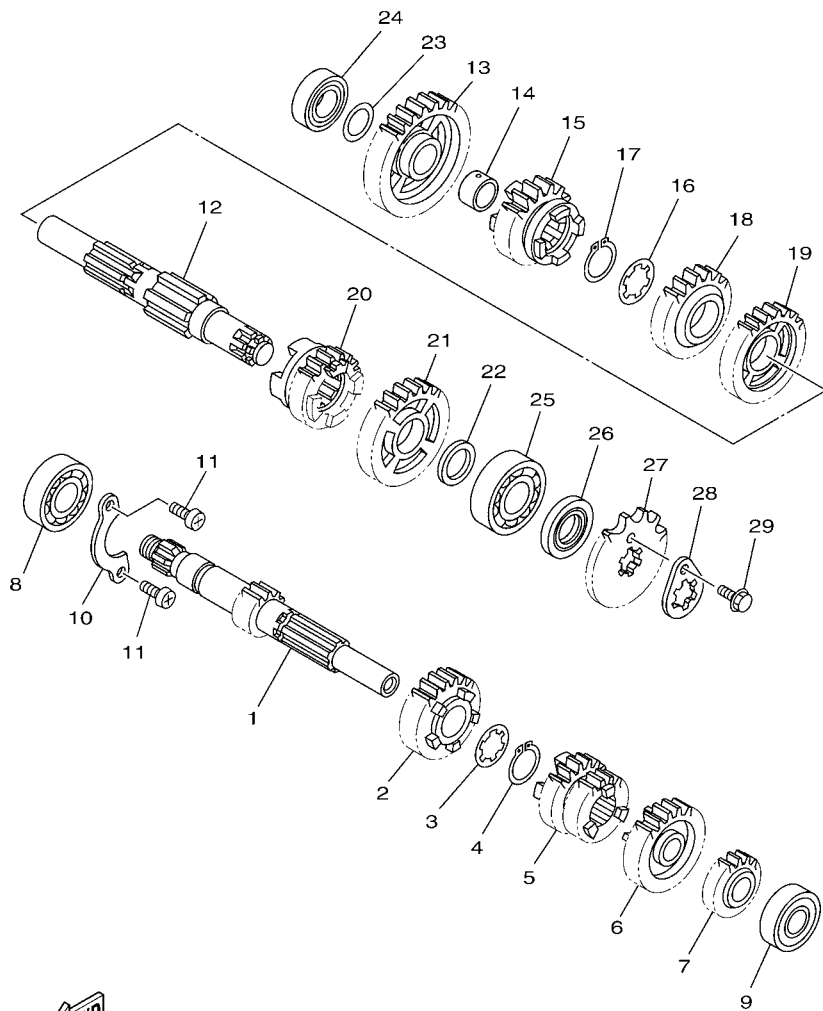

FWD
1CK1470-K140

FIG. 14 TRANSMISION

TRANSMISION

REF. Nº	CODIGO Nº PART NO.	DESCRIPCION DESCRIPTION	B121				OBSERVACIONES REMARKS
28	4LS-E7456-00	SOPORTE DE CORONA HOLDER, SPROCKET	1				
29	95022-06010	PERNO, DE BRIDA BOLT, FLANGE	1				

FIG. 15 LEVA DE CAMBIO & HORQUILLA SHIFT CAM & FORK

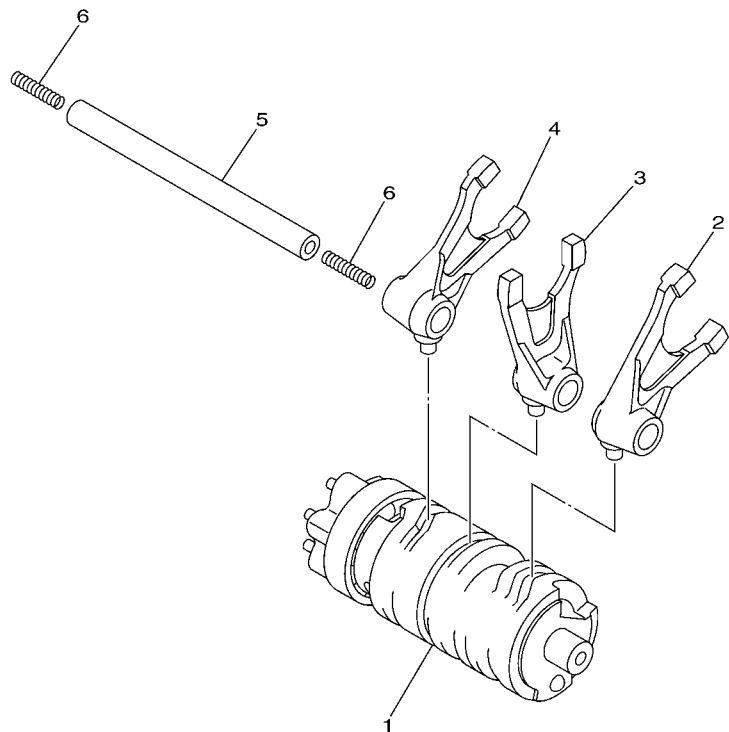

REF. N°	CODIGO N° PART NO.	DESCRIPCION DESCRIPTION	B121				OBSERVACIONES REMARKS
1	1CK-E8540-00	LEVA DEL CAMBIO COMPLETA SHIFT CAM ASSY	1				
2	38B-E8511-00	HORQUILLA DEL CAMBIO 1 FORK, SHIFT 1	1				
3	38B-E8512-00	HORQUILLA DEL CAMBIO 2 FORK, SHIFT 2	1				
4	38B-E8513-00	HORQUILLA DEL CAMBIO 3 FORK, SHIFT 3	1				
5	38B-E8531-00	BARRA GUIA HORQ. CAMBIO 1 BAR, SHIFT FORK GUIDE 1	1				
6	90501-06800	RESORTE DE COMPRESION SPRING, COMPRESSION	2				



3C11460-F160

FIG. 16 EJE DE CAMBIO & PEDAL

SHIFT SHAFT

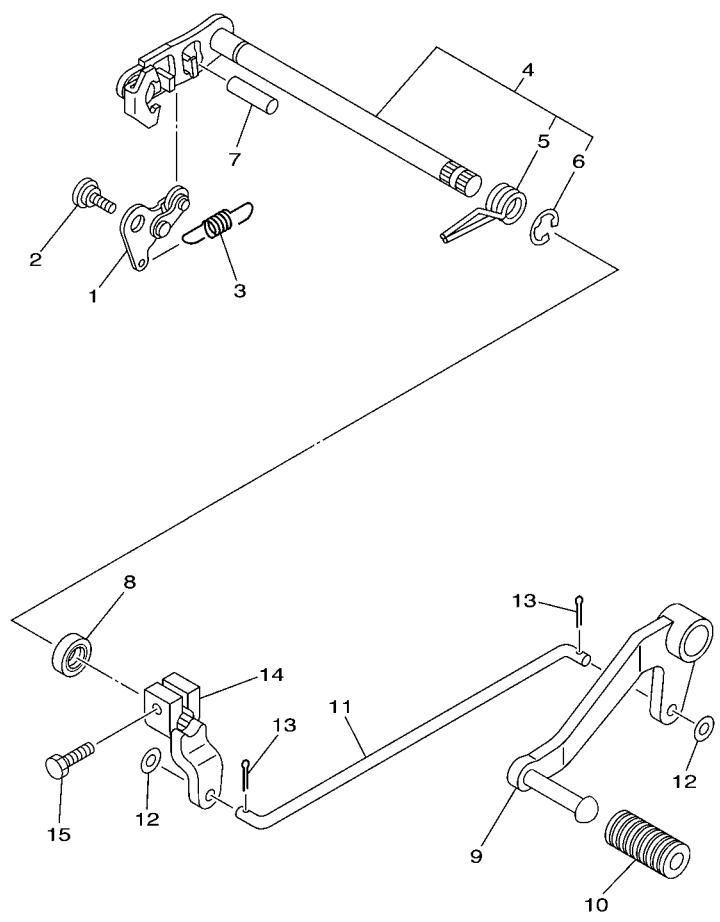

20P1470-G160

REF. N°	CODIGO N° PART NO.	DESCRIPCION DESCRIPTION	B121				OBSERVACIONES REMARKS
1	21C-E8140-00	PALANCA DE TOPE COMPLETA STOPPER LEVER ASSY	1				
2	90109-06259	PERNO BOLT	1				
3	38B-E8337-00	RESORTE SPRING	1				
4	38B-E8101-00	EJE SELECTOR COMPLETO SHIFT SHAFT ASSY	1				
5	90508-32837	.RESORTE DE TORSION .SPRING, TORSION	1				
6	99001-10600	.PRESILLA REDONDA .CIRCLIP	1				
7	93608-30839	PASADOR DE CLAVIJA PIN, DOWEL	1				
8	93102-12809	SELLO ACEITE OIL SEAL	1				
9	20P-E8111-01	PEDAL DEL CAMBIO PEDAL, SHIFT	1				
10	20P-E8113-00	FUNDA DEL PEDAL DEL CAMBIO COVER, SHIFT PEDAL	1				
11	20P-E8115-01	VARILLA DEL CAMBIO ROD, SHIFT	1				
12	92902-06200	ARANDELA WASHER	2				
13	91401-20012	CHAVETA PIN, COTTER	2				
14	20P-E8112-01	BRAZO DEL CAMBIO ARM, SHIFT	1				
15	97024-06020	PERNO BOLT	1				

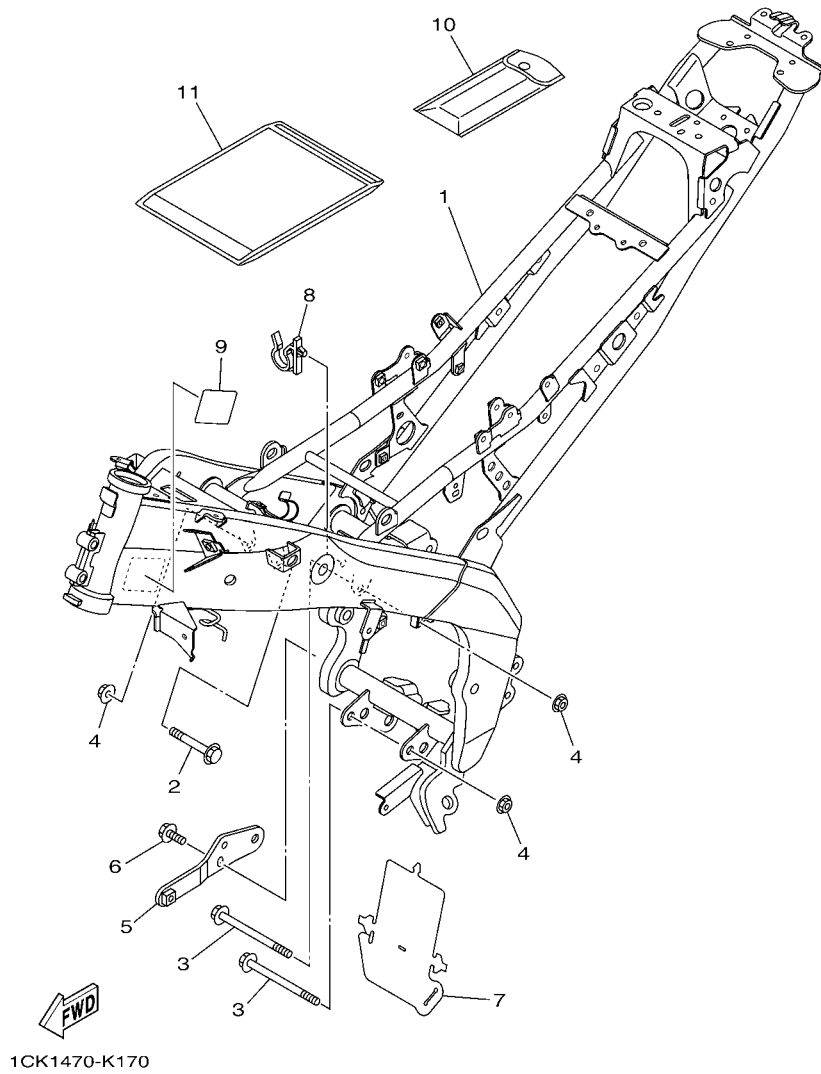

FIG. 17 CUADRO

FRAME

REF. Nº	CODIGO Nº PART NO.	DESCRIPCION DESCRIPTION	B121				OBSERVACIONES REMARKS
1	2FB-F1110-00	ARMAZON COMPLETO FRAME COMP.	1				
2	90105-10323	TORNILLO BOLT, FLANGE	1				
3	90105-10857	TORNILLO BOLT, FLANGE	2				
4	90179-10811	TUERCA NUT	3				
5	20P-F8284-00	MENSULA INFERIOR BRACKET, UNDER	1				
6	95817-08016	TORNILLO BOLT, FLANGE	2				
7	20P-F2327-00	GUARDAFANGO 1 MUD GUARD 1	1				
8	20P-F1338-00	GRAMPA CLAMP	1				
9	1CK-F117G-00	PROTECTOR PROTECTOR	1				
10	1CK-F8100-10	JUEGO DE HERRAMIENTAS TOOL KIT	1				
11	1CK-F8186-00	SACO PLASTICO POUCH	1				

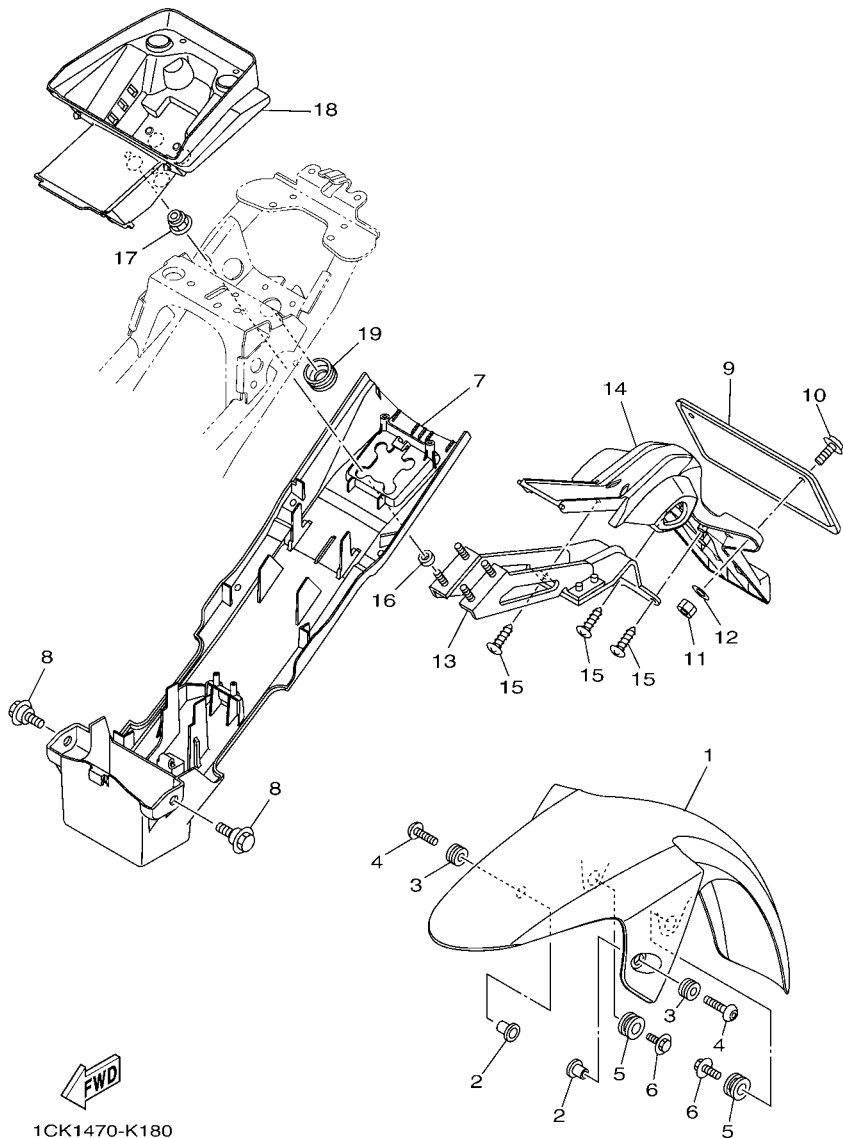

FIG. 18 GUARDABARRO

FENDER

REF. Nº	CODIGO Nº PART NO.	DESCRIPCION DESCRIPTION	B121			OBSERVACIONES REMARKS
1	1CK-F1511-00-6X	GUARDABARRO DELANTERO FENDER, FRONT	1			S3 PARA DBNM8 S3 FOR DBNM8
	1CK-F1511-00-7X	GUARDABARRO DELANTERO FENDER, FRONT	1			BWC1 PARA VRC1 BWC1 FOR VRC1
	1CK-F1511-00-1X	GUARDABARRO DELANTERO FENDER, FRONT	1			DPBMY PARA BWC1 DPBMY FOR BWC1
2	90387-068C8	ESPACIADOR COLLAR	2			
3	90480-12805	TAPON GROMMET	2			
4	90111-06117	TORNILLO BOLT, HEX. SOCKET BUTTON	2			
5	90480-18859	TAPON GROMMET	2			
6	90119-06233	TORNILLO CON ARANDELA BOLT, WITH WASHER	2			
7	1CK-F1611-00	GUARDABARRO TRASERO FENDER, REAR	1			
8	90109-06887	PERNO BOLT	2			
9	21C-F1681-00	PLACA DE LICENCIA PLATE, LICENSE	1			
10	97607-06214	TORNILLO CAB CON PLANA C/ARAN SCREW, WITH WASHER	2			
11	95307-06600	TUERCA NUT	2			
12	90201-06078	ARANDELA PLANA WASHER, PLATE	2			
13	1CK-F1640-00	SOPORTE TRASERO COMPLETO REAR STAY COMP.	1			
14	1CK-F1629-00	GUARDABARRO INFERIOR GUARD, MUD	1			
15	97702-50016	TORNILLO ROSCA HEMBRA SCREW, TAPPING	3			
16	90387-068G0	ESPACIADOR COLLAR	4			
17	95602-06200	TUERCA DE AUTO-CIERRE NUT, SELF-LOCKING	4			
18	1CK-F160E-00	CAJA BOX	1			
19	90480-25482	TAPON GROMMET	1			

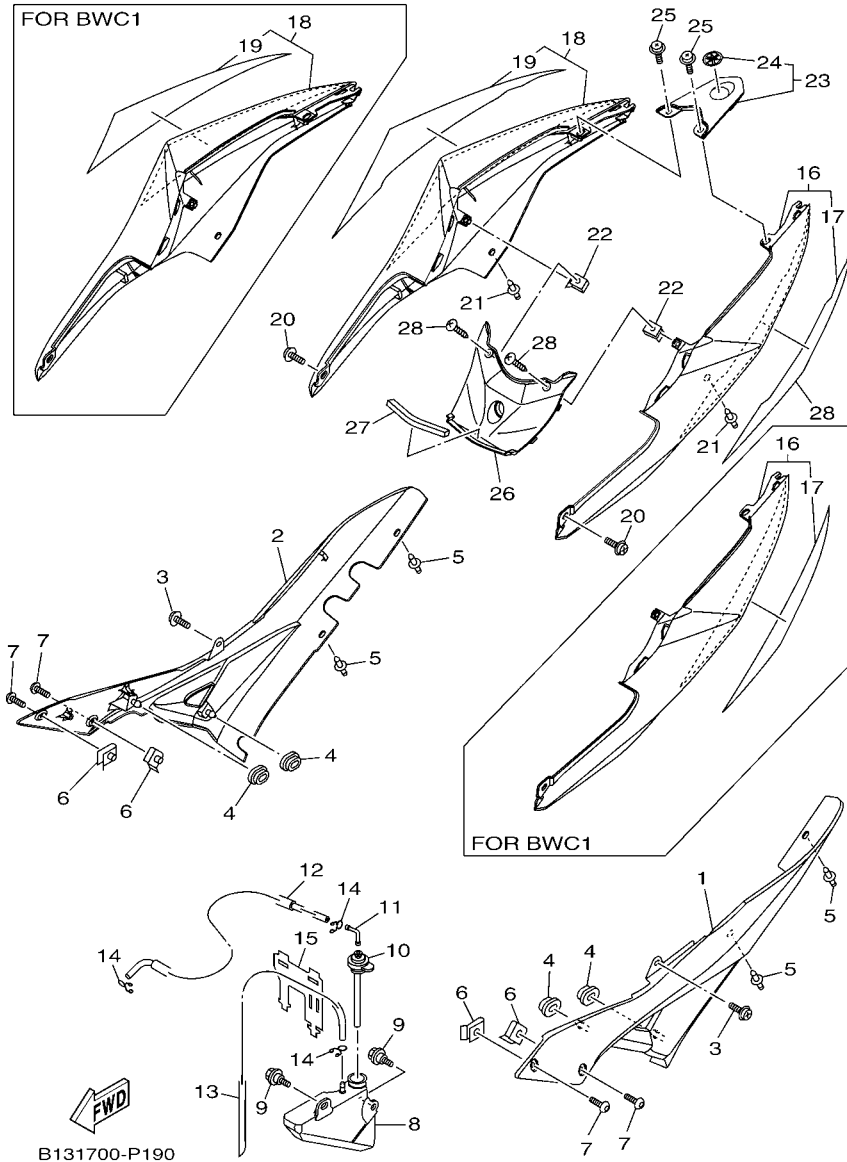

FIG. 19 CUBIERTA LATERAL

SIDE COVER

REF. Nº	CODIGO Nº PART NO.	DESCRIPCION DESCRIPTION	B121			OBSERVACIONES REMARKS
1	1CK-F1711-00	CUBIERTA LATERAL 1 COVER, SIDE 1	1			
2	1CK-F1721-00	CUBIERTA LATERAL 2 COVER, SIDE 2	1			
3	90159-06181	TORNILLO CON VALONA SCREW, WITH WASHER	2			
4	90480-01558	TAPON GROMMET	4			
5	90269-06814	REMACHE RIVET	4			
6	90183-050A7	TUERCA DE RESORTE NUT, SPRING	4			
7	90111-05003	TORNILLO BOLT, HEX. SOCKET BUTTON	4			
8	2FB-F1871-00	TANQUE DE RECUPERACION TANK, RECOVERY	1			
9	90109-06183	PERNO BOLT	2			
10	20P-F1875-00	TAPA CAP	1			
11	20P-F1828-00	CODO ELBOW	1			
12	90445-08831	TUBO HOSE	1			
13	90445-08832	TUBO HOSE	1			
14	90467-08003	PRESILLA CLIP	3			
15	20P-F1823-00	GRAMPA DE MANGUERA CLAMP, HOSE	1			
16	2FB-XF173-00-P5	TAPA LATERAL 3 COVER, SIDE 3	1			SMX PARA DBNM8 SMX FOR DBNM8
	2FB-XF173-10-P5	TAPA LATERAL 3 COVER, SIDE 3	1			SMX PARA VRC1 SMX FOR VRC1
	2FB-XF173-20-P0	TAPA LATERAL 3 COVER, SIDE 3	1			DPBMY PARA BWC1 DPBMY FOR BWC1
17	2FB-F173E-00	.GRAFICO 1 .GRAPHIC 1	1			UR PARA DBNM8 UR FOR DBNM8
	2FB-F173E-10	.GRAFICO 1 .GRAPHIC 1	1			UR PARA VRC1 UR FOR VRC1
	2FB-F173E-20	.GRAFICO 1 .GRAPHIC 1	1			UR PARA BWC1 UR FOR BWC1
18	2FB-XF174-00-P5	CUBIERTA LATERAL 4 COVER, SIDE 4	1			SMX PARA DBNM8 SMX FOR DBNM8
	2FB-XF174-10-P5	CUBIERTA LATERAL 4 COVER, SIDE 4	1			SMX PARA VRC1 SMX FOR VRC1
	2FB-XF174-20-P0	CUBIERTA LATERAL 4 COVER, SIDE 4	1			DPBMY PARA BWC1 DPBMY FOR BWC1
19	2FB-F173F-00	.GRAFICO 2 .GRAPHIC 2	1			UR PARA DBNM8 UR FOR DBNM8
	2FB-F173F-10	.GRAFICO 2 .GRAPHIC 2	1			UR PARA VRC1 UR FOR VRC1
	2FB-F173F-20	.GRAFICO 2 .GRAPHIC 2	1			UR PARA BWC1 UR FOR BWC1

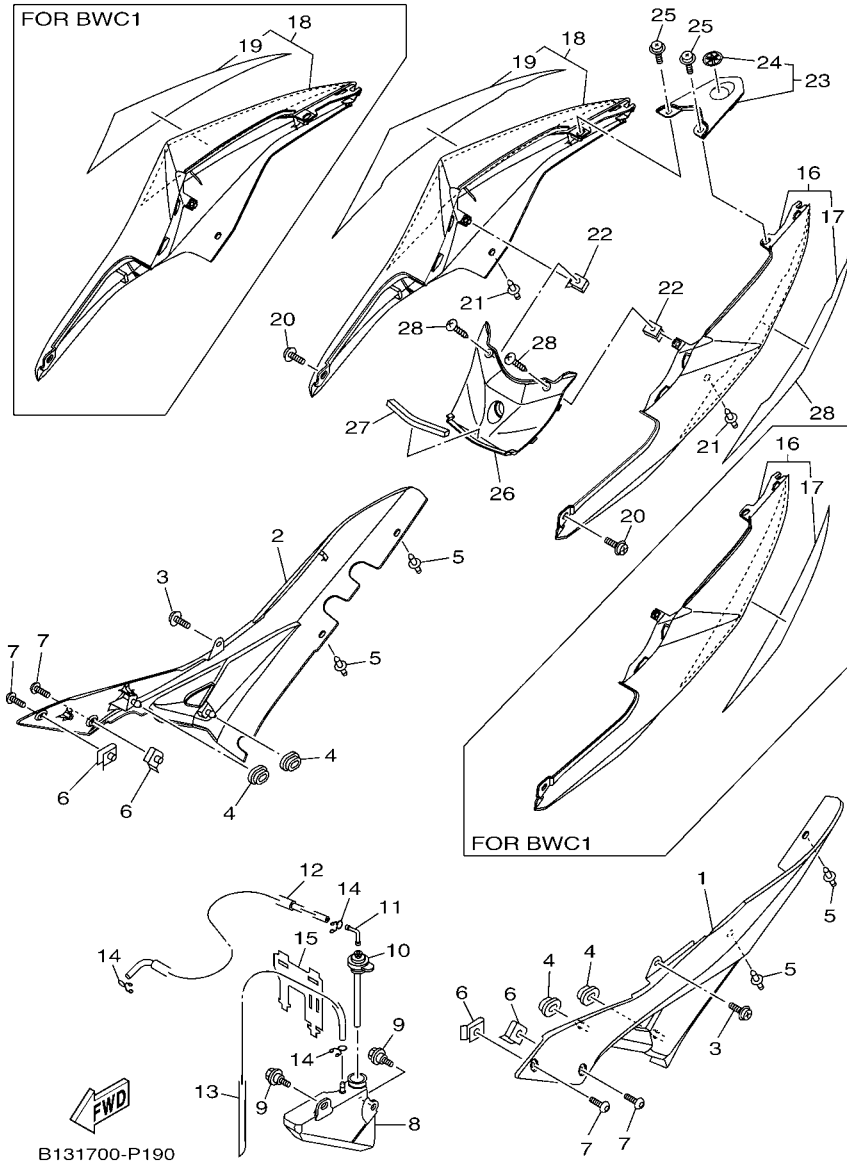

FIG. 19 CUBIERTA LATERAL

SIDE COVER

REF. Nº	CODIGO Nº PART NO.	DESCRIPCION DESCRIPTION	B121				OBSERVACIONES REMARKS
20	90159-06181	TORNILLO CON VALONA SCREW, WITH WASHER	2				
21	90269-06814	REMACHE RIVET	2				
22	90183-05818	TUERCA DE RESORTE NUT, SPRING	2				
23	1CK-XF17C-10-P1	CUBIERTA LATERAL 5 COVER, SIDE 5	1				UR PARA DBNM8 UR FOR DBNM8
	1CK-XF17C-10-P3	CUBIERTA LATERAL 5 COVER, SIDE 5	1				UR PARA VRC1 UR FOR VRC1
	1CK-XF17C-20-P2	CUBIERTA LATERAL 5 COVER, SIDE 5	1				UR PARA BWC1 UR FOR BWC1
24	20P-F836B-00	.MARCA .TUNING FORK MARK	1				PARA DBNM8,VRC1 FOR DBNM8,VRC1
	1CK-F836B-00	.MARCA .TUNING FORK MARK	1				PARA BWC1 FOR BWC1
25	90159-06181	TORNILLO CON VALONA SCREW, WITH WASHER	2				
26	1CK-F171X-00-P1	CUBIERTA LATERAL 6 COVER, SIDE 6	1				UR PARA DBNM8 UR FOR DBNM8
	1CK-F171X-00-P3	CUBIERTA LATERAL 6 COVER, SIDE 6	1				UR PARA VRC1 UR FOR VRC1
	1CK-F171X-00-P2	CUBIERTA LATERAL 6 COVER, SIDE 6	1				UR PARA BWC1 UR FOR BWC1
27	90520-08801	EQUILIBRIO, CUBIERTA DAMPER, PLATE	1				
28	97707-50012	TORNILLO SCREW, TRUSS HEAD TAPPING	2				

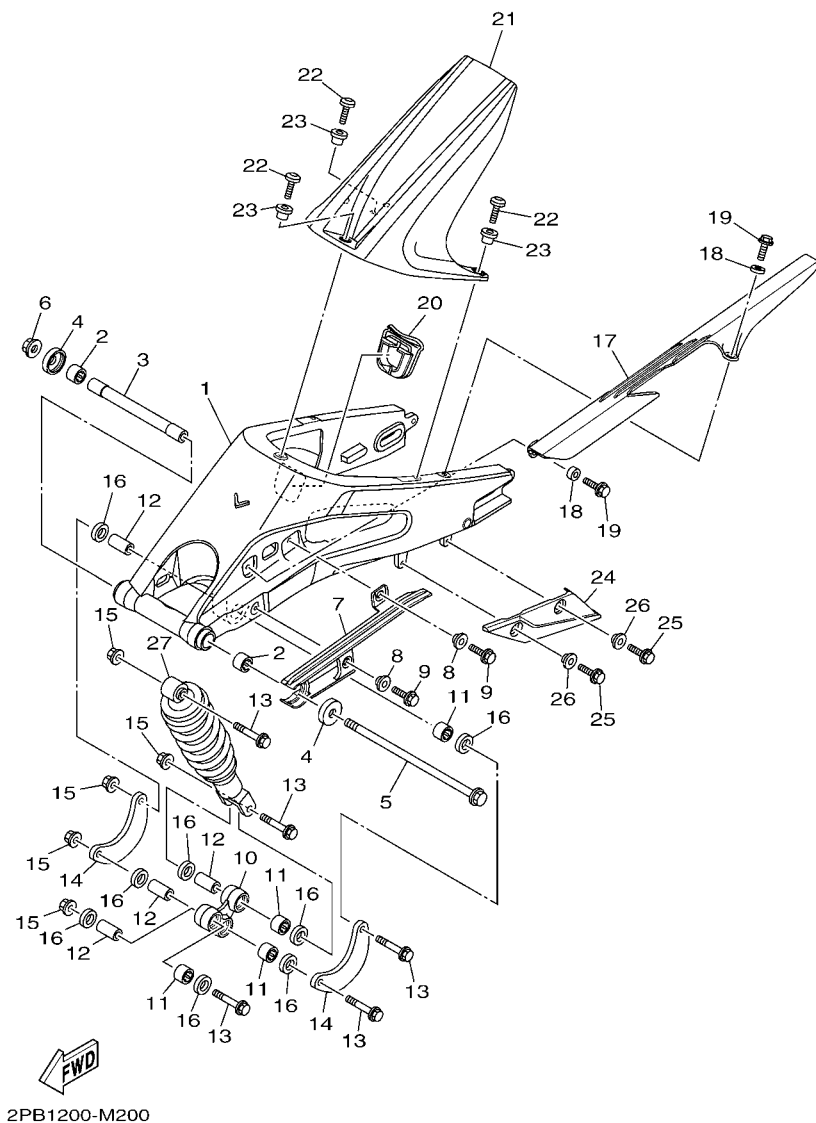

FIG. 20 BRAZO TRASERO & SUSPENSION REAR ARM & SUSPENSION

REF. Nº	CODIGO Nº PART NO.	DESCRIPCION DESCRIPTION	B121			OBSERVACIONES REMARKS
1	1CK-F2110-00	BRAZO TRASERO COMPLETO REAR ARM COMP.	1			
2	93317-318Y5	COJINETE BEARING	2			
3	20P-F2184-00	BUJE BUSH	1			
4	1CK-F2128-00	TAPA DE EMPIJE 1 COVER, THRUST 1	2			
5	20P-F2141-00	EJE DEL BARCULANTE SHAFT, PIVOT	1			
6	95707-12500	TUERCA DE BRIDA NUT, FLANGE	1			
7	1CK-F2151-00	SELLO DE GUARDA SEAL, GUARD	1			
8	90387-07819	ESPACIADOR COLLAR	2			
9	95827-06014	TORNILLO BOLT, FLANGE	2			
10	1CK-F217A-00	BRAZO REEURIO ARM, RELAY	1			
11	93315-31758	COJINETE DE RODILLOS BEARING	4			
12	90387-10814	ESPACIADOR COLLAR	4			
13	90105-10311	TORNILLO BOLT, FLANGE	5			
14	2PK-F217F-00	BIELA COMPLETA 1 ROD, CONNECTING 1	2			
15	90179-10813	TUERCA NUT	5			
16	93106-17802	SELLO ACEITE OIL SEAL	8			
17	1CK-F2311-00	CABRECADENA CASE, CHAIN	1			
18	90387-068G0	ESPACIADOR COLLAR	2			
19	95827-06014	TORNILLO BOLT, FLANGE	2			
20	1CK-F219X-00	CUBIERTA COVER	1			
21	2PB-F1650-00	GUARDABARRO TRANSERO COMP. REAR FENDER COMP.	1			
22	90111-06139	TORNILLO BOLT, HEX. SOCKET BUTTON	3			
23	90387-068H0	ESPACIADOR COLLAR	3			
24	1CK-F2147-00	PROTECTOR DE CADENA PROTECTOR, CHAIN	1			
25	95827-06014	TORNILLO BOLT, FLANGE	2			
26	90387-07819	ESPACIADOR COLLAR	2			
27	1CK-F2210-00	AMORTIGUADOR TRASERO COMPLETO SHOCK ABSORBER ASSY, REAR	1			

20P1470-G210

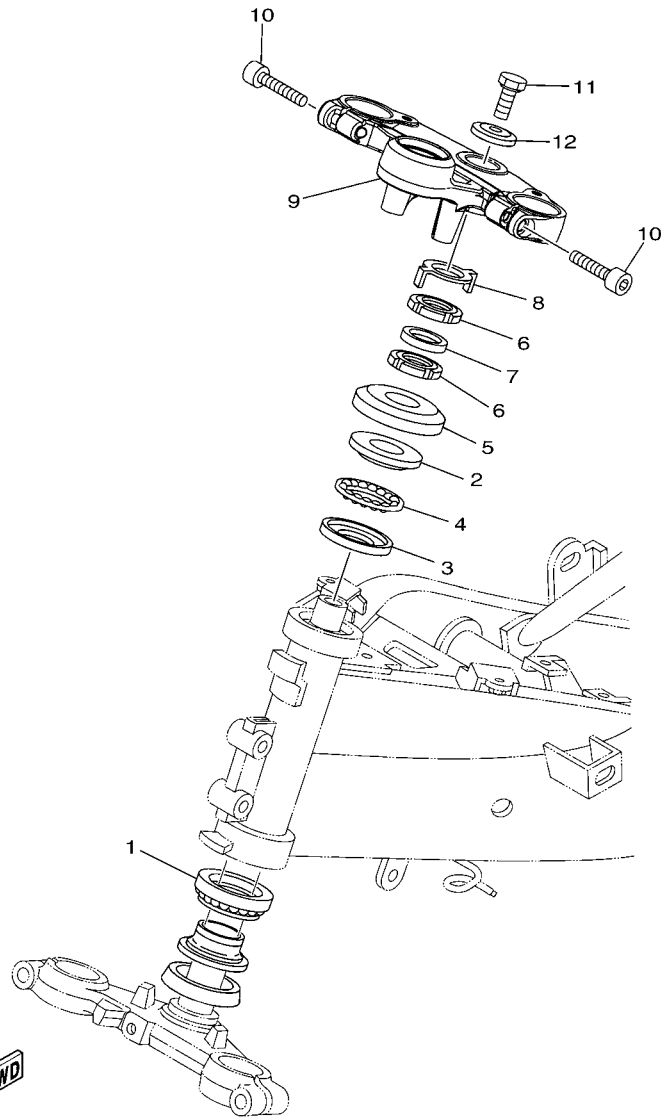

FIG. 21 DIRECCION

STEERING

REF. N°	CODIGO N° PART NO.	DESCRIPCION DESCRIPTION	B121				OBSERVACIONES REMARKS
1	5BP-F3873-01	COJINETE SUP.DIRECCION BEARING, STEERING UPPER	1				
2	183-23411-00	PISTA DE BOLAS 1 RACE, BALL 1	1				
3	183-23412-00	PISTA DE BOLAS 2 RACE, BALL 2	1				
4	5TL-2341E-00	RETEN DE COJINETE (16) RETAINER, BALL BEARING (16)	1				
5	20P-F3416-00	CUBIERTA DE BASE DE BOLA 2 COVER, BALL RACE 2	1				
6	90179-25615	TUERCA NUT	2				
7	90202-26142	ARANDELA DE PLANA WASHER, PLATE	1				
8	20P-F3418-00	ARANDELA ESPECIAL WASHER, SPECIAL	1				
9	20P-F3435-00	PLATINA SUPERIOR CROWN, HANDLE	1				
10	91317-08030	PERNO BOLT	2				
11	90105-10006	TORNILLO BOLT, FLANGE	1				
12	90209-10020	ARANDELA DE SEPARACION WASHER	1				

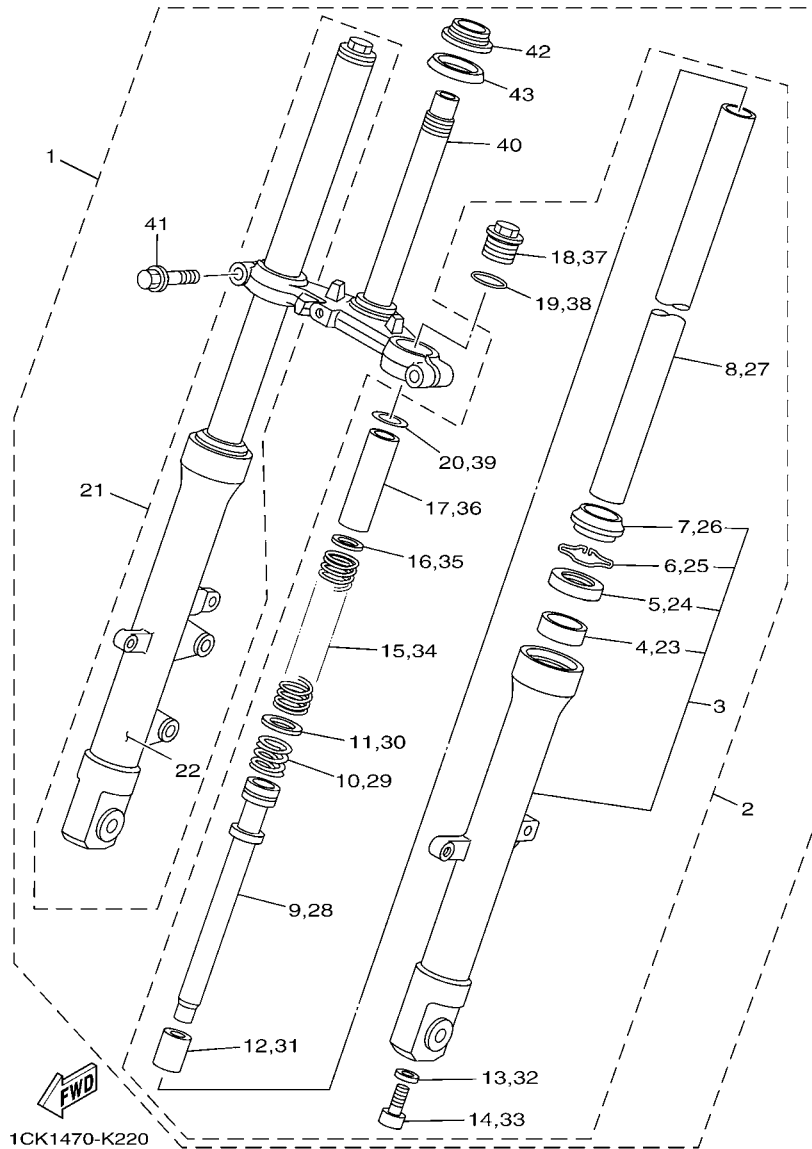

FIG. 22 HORQUILLA DELANTERA FRONT FORK

REF. Nº	CODIGO Nº PART NO.	DESCRIPCION DESCRIPTION	B121			OBSERVACIONES REMARKS
1	1CK-F3100-00	HORQUILLA DELANTERA COMPLETA FRONT FORK ASSY	1			
2	1CK-F3102-00	..HORQUILLA DELANTERA COMPL.(MI) ..FRONT FORK ASSY (L.H)	1			
3	1CK-F3126-00	..TUBO EXTERIOR (IZQUIERDO) ..TUBE, OUTER (L.H)	1			
4	20P-F3125-00	..METAL CORREDIZO 1 ..METAL, SLIDE 1	1			
5	20P-F3145-00	..RETEN DE ACEITE ..OIL SEAL	1			
6	20P-F3156-10	..ANILLO DE ENGANCHE ..RING, SNAP	1			
7	20P-F3144-00	..GUARDAPOLVO ..SEAL, DUST	1			
8	20P-F3110-00	..TUBO INTERIOR COMPLETO 1 ..INNER TUBE COMP.1	1			
9	20P-F3170-00	..CILINDRO COMPL DE HORQ DELANT ..CYLINDER COMP., FRONT FORK	1			
10	20P-F3151-00	..RESORTE DE REBOTE ..SPRING, REBOUND	1			
11	20P-F3157-00	..ANILLO DEL PISTON ..RING, PISTON	1			
12	20P-F3173-00	..VASTAGO AHUSADO ..SPINDLE, TAPER	1			
13	21C-F3158-00	..EMPAQUE ..GASKET	1			
14	21C-F3181-10	..TORNILLO CABEZAHEXAGONAL ..BOLT, HEXAGON SOCKET HEAD	1			
15	20P-F3141-00	..RESORTE HORQUILLA DELANT. ..SPRING, FRONT FORK	1			
16	20P-F3149-00	..ARANDELA DE RESORTE SUPERIOR ..WASHER, SPRING UPPER	1			
17	20P-F3118-00	..SEPARADOR ..SPACER	1			
18	20P-F3111-00	..PERNO DE TAPA ..BOLT, CAP	1			
19	20P-F3114-00	..EMPAQUE ..O-RING	1			
20	1CK-F3738-00	..ARANDELA 2 ..WASHER 2	1			
21	1CK-F3103-00	..HORQUILLA DELANTERA COMPL.(MD) ..FRONT FORK ASSY (R.H)	1			
22	1CK-F3136-00	..TUBO EXTERIOR 2 ..TUBE, OUTER	1			
23	20P-F3125-00	..METAL CORREDIZO 1 ..METAL, SLIDE 1	1			
24	20P-F3145-00	..RETEN DE ACEITE ..OIL SEAL	1			
25	20P-F3156-10	..ANILLO DE ENGANCHE ..RING, SNAP	1			
26	20P-F3144-00	..GUARDAPOLVO ..SEAL, DUST	1			
27	20P-F3110-00	..TUBO INTERIOR COMPLETO 1 ..INNER TUBE COMP.1	1			

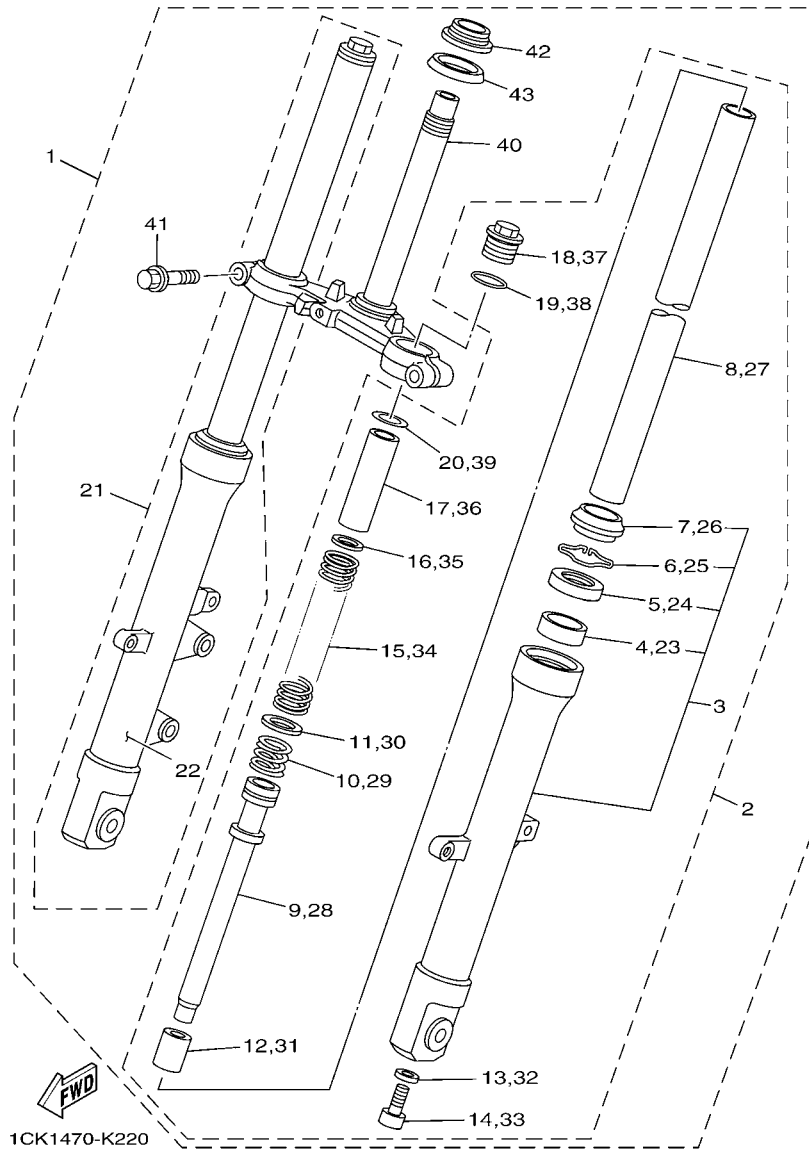

FIG. 22 HORQUILLA DELANTERA FRONT FORK

REF. Nº	CODIGO Nº PART NO.	DESCRIPCION DESCRIPTION	B121				OBSERVACIONES REMARKS
28	20P-F3170-00	..CILINDRO COMPL. DE HORQ DELANT ..CYLINDER COMP., FRONT FORK	1				
29	20P-F3151-00	..RESORTE DE REBOTE ..SPRING, REBOUND	1				
30	20P-F3157-00	..ANILLO DEL PISTON ..RING, PISTON	1				
31	20P-F3173-00	..VASTAGO AHUSADO ..SPINDLE, TAPER	1				
32	21C-F3158-00	..EMPAQUE ..GASKET	1				
33	21C-F3181-10	..TORNILLO CABEZA HEXAGONAL ..BOLT, HEXAGON SOCKET HEAD	1				
34	20P-F3141-00	..RESORTE HORQUILLA DELANT. ..SPRING, FRONT FORK	1				
35	20P-F3149-00	..ARANDELA DE RESORTE SUPERIOR ..WASHER, SPRING UPPER	1				
36	20P-F3118-00	..SEPARADOR ..SPACER	1				
37	20P-F3111-00	..PERNO DE TAPA ..BOLT, CAP	1				
38	20P-F3114-00	..EMPAQUE ..O-RING	1				
39	1CK-F3738-00	..ARANDELA 2 ..WASHER 2	1				
40	20P-F3340-00	..PLATINA INFERIOR COMPLETA ..UNDER BRACKET COMP.	1				
41	20P-F3346-00	..PERNO 1 ..BOLT 1	2				
42	5BP-F3875-00	..COJINETE ..BEARING, STEERING LOWER	1				
43	5YY-F3462-00	..SELLÓ PARA POLVO ..SEAL, DUST	1				

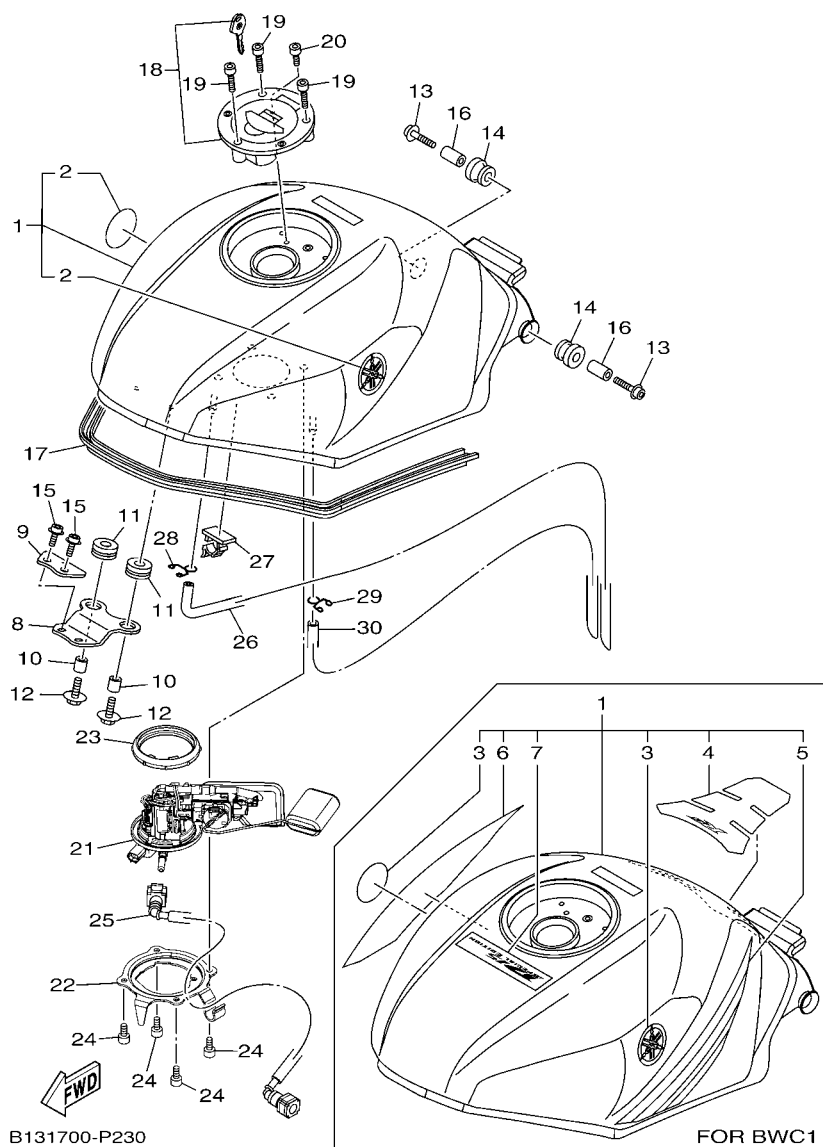

FIG. 23 DEPOSITO DE COMBUSTIBLE FUEL TANK

REF. Nº	CODIGO Nº PART NO.	DESCRIPCION DESCRIPTION	B121			OBSERVACIONES REMARKS
1	2FB-XF41A-00-P0	DEPOSITO DE COMBUSTIBLE COMP. FUEL TANK COMP.	1			UR PARA DBNM8 UR FOR DBNM8
	2FB-XF41A-00-P1	DEPOSITO DE COMBUSTIBLE COMP. FUEL TANK COMP.	1			UR PARA VRC1 UR FOR VRC1
	2FB-XF41A-00-P2	DEPOSITO DE COMBUSTIBLE COMP. FUEL TANK COMP.	1			UR PARA BWC1 UR FOR BWC1
2	5YY-F413B-00	.EMBLEMA .EMBLEM	2			PARA DBNM8,VRC1 FOR DBNM8,VRC1
3	1CK-F413B-00	.EMBLEMA .EMBLEM	2			PARA BWC1 FOR BWC1
4	1CK-F416B-10	.EMBLEMA .EMBLEM	1			PARA BWC1 FOR BWC1
5	2FB-F4245-00	.CALCOMANIA DEPOSITO COMBUST.2 .GRAPHIC, FUEL TANK 2	1			PARA BWC1 FOR BWC1
6	2FB-F4246-00	.CALCOMANIA 3 .GRAPHIC 3	1			PARA BWC1 FOR BWC1
7	2FB-F4244-00	.CALCOMANIA DEPOSITO COMBUST.1 .GRAPHIC, FUEL TANK 1	1			PARA BWC1 FOR BWC1
8	20P-F4191-00	SOPORTE DEPOSITO DE COMBUST.1 BRACKET, FUEL TANK 1	1			
9	20P-F411F-00	PLACA, ADITAMENTO PLATE, FITTING	1			
10	90387-068B2	ESPACIADOR COLLAR	2			
11	90480-15483	TAPON GROMMET	2			
12	90105-06169	TORNILLO BOLT, FLANGE	2			
13	90110-06287	TORNILLO ALLEN BOLT, HEXAGON SOCKET HEAD	2			
14	90480-18549	TAPON GROMMET	2			
15	90110-06215	TORNILLO ALLEN BOLT, HEXAGON SOCKET HEAD	2			
16	90387-06890	ESPACIADOR COLLAR	2			
17	20P-F4188-00	MOLDURA DEPOSITO COMBUST. MOLD, FUEL TANK	1			
18	2FB-WF461-00	TAPA DE DEPOSITO COMPLETO CAP ASSY WITH LOCK	1			
19	90110-05806	TORNILLO ALLEN BOLT, HEXAGON SOCKET HEAD	3			
20	91312-05010	TORNILLO BOLT	1			
21	2FB-E3907-00	BOMBA DE COMBUSTIBLE COMPLETA FUEL PUMP COMP.	1			
22	2FB-F4491-00	SOPORTE BOMBA COMBUSTIBLE BRACKET, FUEL PUMP	1			
23	2GS-F414G-00	SELLO SEAL	1			
24	91312-05010	TORNILLO BOLT	4			
25	2FB-E3971-00	ANILLO DE ESPACIADOR PIPE, FUEL 1	1			

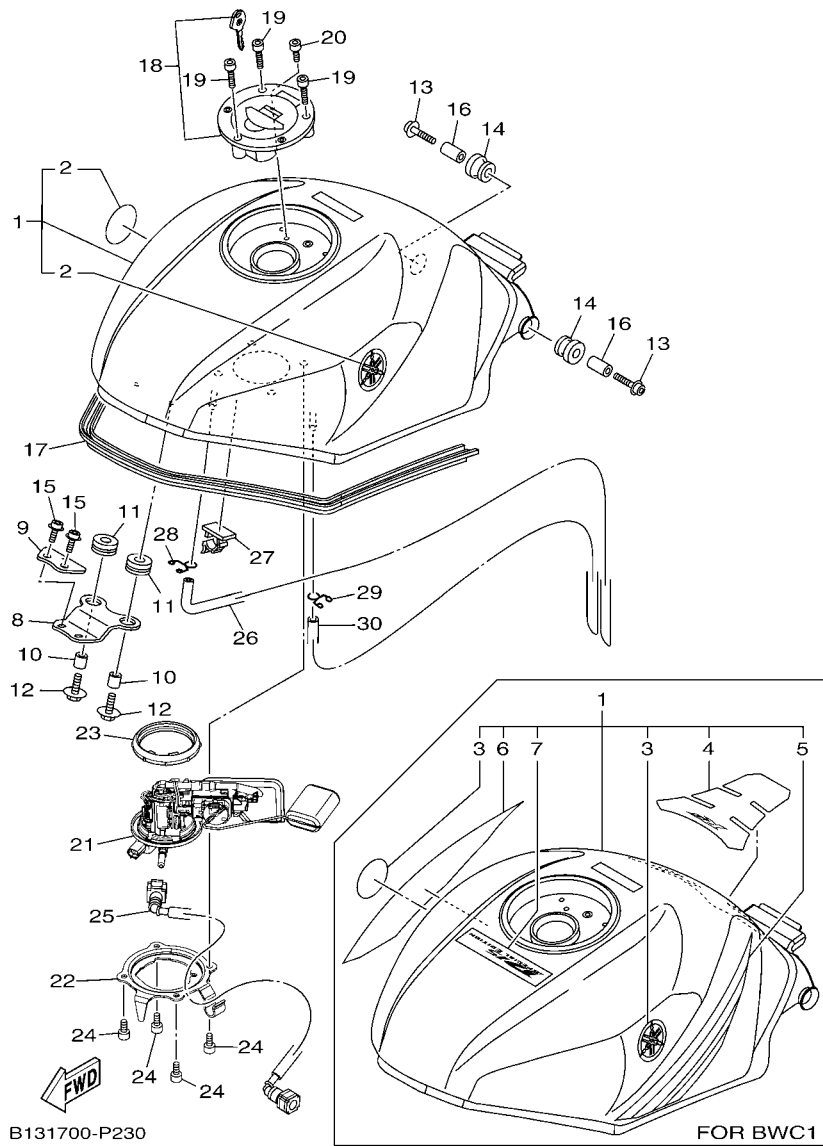
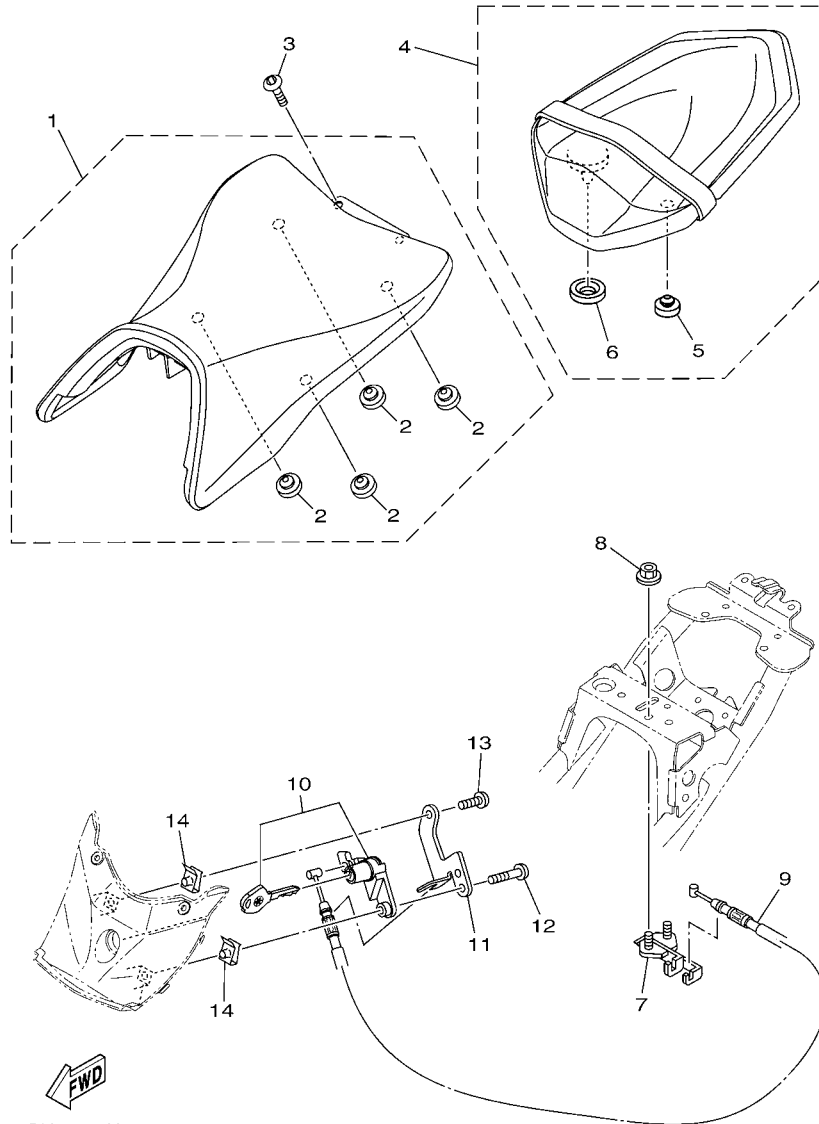

FIG. 23 DEPOSITO DE COMBUSTIBLE FUEL TANK

REF. Nº	CODIGO Nº PART NO.	DESCRIPCION DESCRIPTION	B121				OBSERVACIONES REMARKS
26	20P-F4312-00	TUBO 2 PIPE 2	1				
27	90464-10801	BRIDA CLAMP	1				
28	90467-09006	PRESILLA CLIP	1				
29	90467-09006	PRESILLA CLIP	1				
30	90445-105G5	TUBO (L700) HOSE (L700)	1				
<hr/>							
<hr/>							
<hr/>							
<hr/>							
<hr/>							
<hr/>							
<hr/>							
<hr/>							
<hr/>							
<hr/>							



1CK1470-K240

FIG. 24 ASIENTO

SEAT

REF. Nº	CODIGO Nº PART NO.	DESCRIPCION DESCRIPTION	B121				OBSERVACIONES REMARKS
1	1CK-F4710-00	ASIENTO SIMPLE COMPLETO SINGLE SEAT ASSY	1				
2	1PM-F4741-00	.COJIN DE ASIENTO .PAD, SEAT	4				
3	92012-08012	PERNO BOLT, BUTTON HEAD	2				
4	1CK-F4750-00	ASIENTO TANDEM COMPLETO TANDEM SEAT ASSY	1				
5	4LS-F4741-00	.COJIN DE ASIENTO .PAD, SEAT	1				
6	21C-F4763-00	.COJIN DE ASIENTO 2 .PAD, SEAT 2	1				
7	20P-F4780-00	CERRADURA SILLIN COMPLETO SEAT LOCK ASSY	1				
8	95707-06500	TUERCA DE BRIDA NUT, FLANGE	2				
9	1CK-F478E-00	CABLE CABLE, SEAT LOCK	1				
10	1CK-WF47E-00	ASIENTO DE CIERRE COMPLETO SEAT LOCK ASSY	1				
11	1CK-F117K-00	SOPORTE DE CERRADURA STAY, LOCK	1				
12	98507-05020	TORNILLO DE CABEZA PLANA SCREW, PAN HEAD	1				
13	98507-05012	TORNILLO DE CABEZA PLANA SCREW, PAN HEAD	1				
14	90183-05076	TUERCA DE RESORTE NUT, SPRING	2				

FIG. 25 RUEDA DELANTERA

FRONT WHEEL

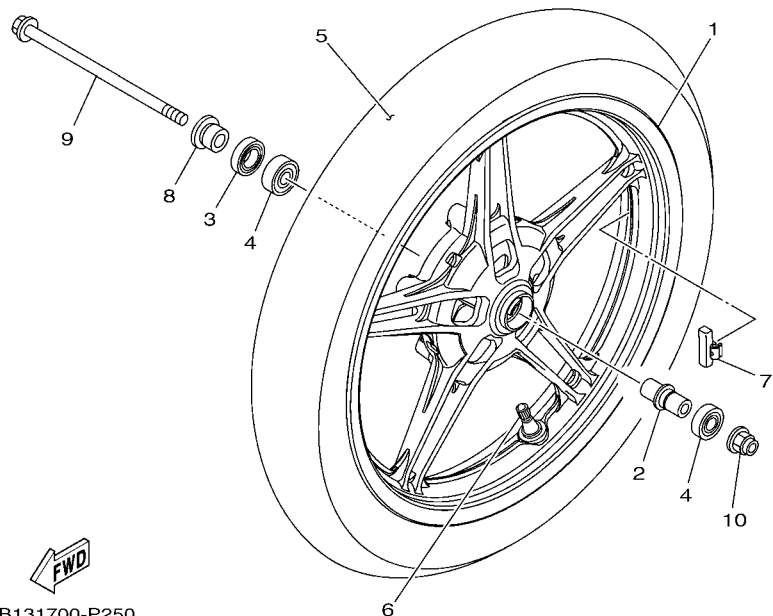
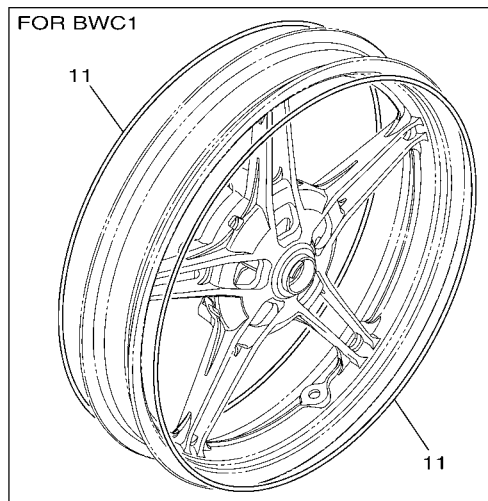

REF. Nº	CODIGO Nº PART NO.	DESCRIPCION DESCRIPTION	B121			OBSERVACIONES REMARKS
1	1CK-F5168-00-33	RUEDA FUNDIDA DELANTERA CAST WHEEL, FRONT	1			YB YB
2	1CK-F510C-00	COLLAR COLLAR ASSY.	1			
3	93106-22808	SELLO ACEITE OIL SEAL	1			
4	93306-252YH	COJINETE BEARING	2			
5	94109-17803	NEUMATICO (90/80-17 M/C 46P) TIRE (90/80-17 M/C 46P)	1			MRF MRF
6	93900-00824	VALVULA VALVE, RIM	1			
7	5MT-25398-00	BALANCEADOR DE RUEDA (10G) BALANCER, WHEEL (10G)	1			UN UN
	5MT-25398-10	BALANCEADOR DE RUEDA (20G) BALANCER, WHEEL (20G)	1			UN UN
	5MT-25398-20	BALANCEADOR DE RUEDA (30G) BALANCER, WHEEL (30G)	1			UN UN
8	1CK-F5186-00	COLLAR DE RUEDA COLLAR, WHEEL	1			
9	1CK-F5181-00	EJE DE LA RUEDA AXLE, WHEEL	1			
10	95602-14200	TUERCA DE AUTO-CIERRE NUT, SELF-LOCKING	1			
11	1CK-F531B-10	EMBLEMA DE RUEDA EMBLEM, WHEEL	2			PARA BWC1 FOR BWC1

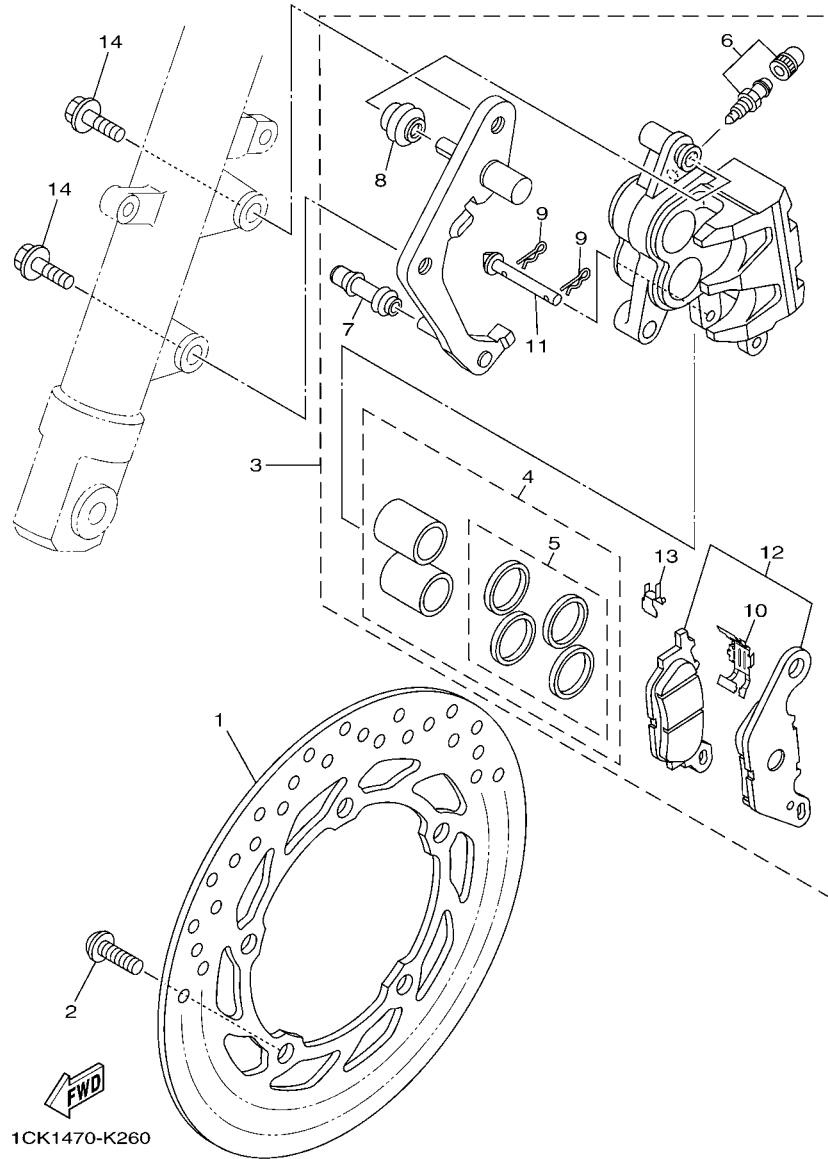

FIG. 26 CALIBRE FRENO DELANTERA FRONT BRAKE CALIPER

REF. N°	CODIGO N° PART NO.	DESCRIPCION DESCRIPTION	B121				OBSERVACIONES REMARKS
1	1CK-F582U-00	DISCO DE FRENO (DERECHO) DISK, BRAKE (RIGHT)	1				
2	90111-08847	TORNILLO BOLT, HEX. SOCKET BUTTON	5				
3	2FB-F580U-00	CALIBRE COMPLETO (DERECHO) CALIPER ASSY (RIGHT)	1				
4	3C1-F5802-00	.PISTON COMPLETO PINZA .PISTON ASSY, CALIPER	1				
5	3C1-F5803-50	..JUEGO DE RETENES DE PINZA ..CALIPER SEAL KIT	1				
6	4C9-W0048-00	.CJTO TORNILLO DE PURGA .BLEED SCREW KIT	1				
7	5YP-F5937-00	.FUNDA .BOOT 2	1				
8	5YP-F5917-00	.FUNDA DE CALIBRE .BOOT, CALIPER	1				
9	5YP-F5925-01	.PRESILLA .CLIP	2				
10	5P0-F5919-00	.SOPORTE DE PASTILLAS .SUPPORT, PAD	1				
11	5YP-F5924-00	.PASADOR .PIN, PAD	1				
12	3C1-F5805-10	.JUEGO DE COJIN DE FRENO .BRAKE PAD KIT	1				
13	5YP-F5939-00	.PRESILLA .CLIP, PAD	1				
14	90105-10082	TORNILLO BOLT, FLANGE	2				

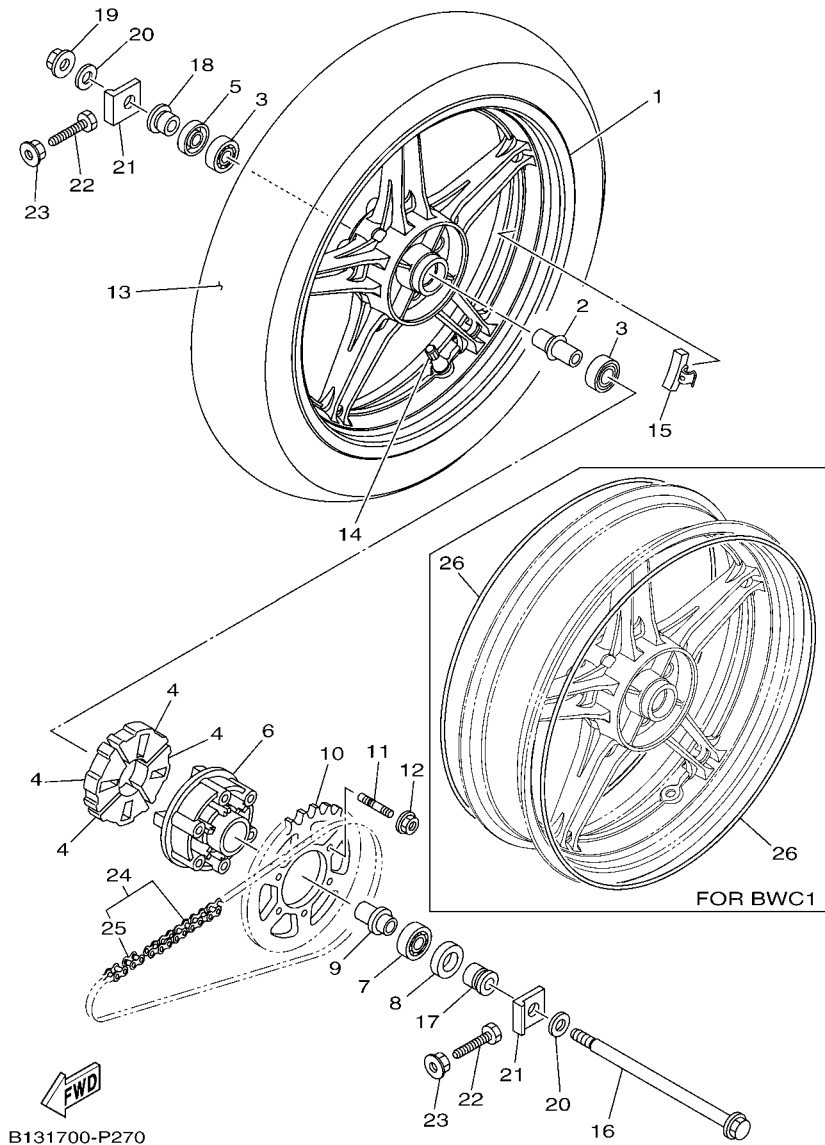

FIG. 27 RUEDA TRASERA

REAR WHEEL

REF. N°	CODIGO N° PART NO.	DESCRIPCION DESCRIPTION	B121			OBSERVACIONES REMARKS
1	1CK-F5338-00-33	RUEDA FUNDIDA TRASERA CAST WHEEL, REAR	1			YB YB
2	1CK-F530S-00	ASAMBLA DE COLLAR COLLAR ASSY	1			
3	93306-252YH	COJINETE BEARING	2			
4	54B-F5364-00	AMORTIGUADOR DAMPER	4			
5	93106-22808	SELLO ACEITE OIL SEAL	1			
6	20P-F5366-00-33	EMBRAGUE DE MASA CLUTCH, HUB	1			YB YB
7	93306-054Y5	COJINETE BEARING	1			
8	93106-26801	SELLO ACEITE OIL SEAL	1			
9	1CK-F5377-00	COLLAR DE RUEDA COLLAR, WHEEL	1			
10	1CK-F5447-00	CORONA (47T) SPROCKET, DRIVEN (47T)	1			
11	90116-08826	ESPARRAGO BOLT, STUD	6			
12	95602-08200	TUERCA DE AUTO-CIERRE NUT, SELF-LOCKING	6			
13	94113-17806	NEUMATICO (130/70R17 M/C 62P) TIRE (130/70R17 M/C 62P)	1			MRF MRF
14	93900-00824	VALVULA VALVE, RIM	1			
15	5MT-25398-00	BALANCEADOR DE RUEDA (10G) BALANCER, WHEEL (10G)	1			UN UN
	5MT-25398-10	BALANCEADOR DE RUEDA (20G) BALANCER, WHEEL (20G)	1			UN UN
	5MT-25398-20	BALANCEADOR DE RUEDA (30G) BALANCER, WHEEL (30G)	1			UN UN
16	1CK-F5381-00	EJE DE RUEDA AXLE, WHEEL	1			
17	1CK-F5386-00	COLLAR EJE DE RUEDA DENTADA COLLAR, SPROCKET AXLE	1			
18	1CK-F5383-00	COLLAR DE RUEDA COLLAR, WHEEL	1			
19	95602-14200	TUERCA DE AUTO-CIERRE NUT, SELF-LOCKING	1			
20	90201-15837	ARANDELA PLANA WASHER, PLATE	2			
21	1CK-F5388-00	TIRADOR DE CADENA 1 PULLER, CHAIN 1	2			
22	90101-08006	TORNILLO BOLT	2			
23	95702-08500	TUERCA DE BRIDA NUT, FLANGE	2			
24	94568-E5132	CADENA (DID 428VIX 132LL) CHAIN (DID 428VIX 132LL)	1			
25	94668-E5021	.CONECTOR DE CADENA(DID 428VIX) .JOINT, CHAIN (DID 428VIX)	1			

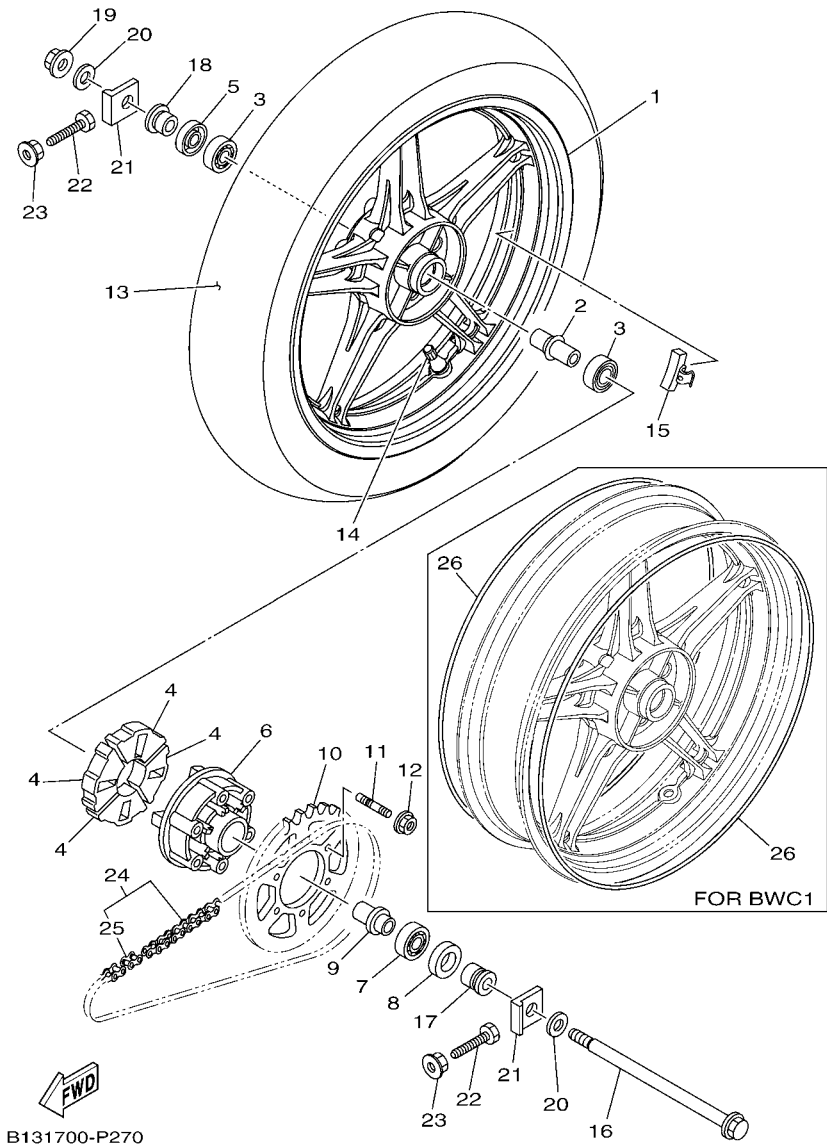
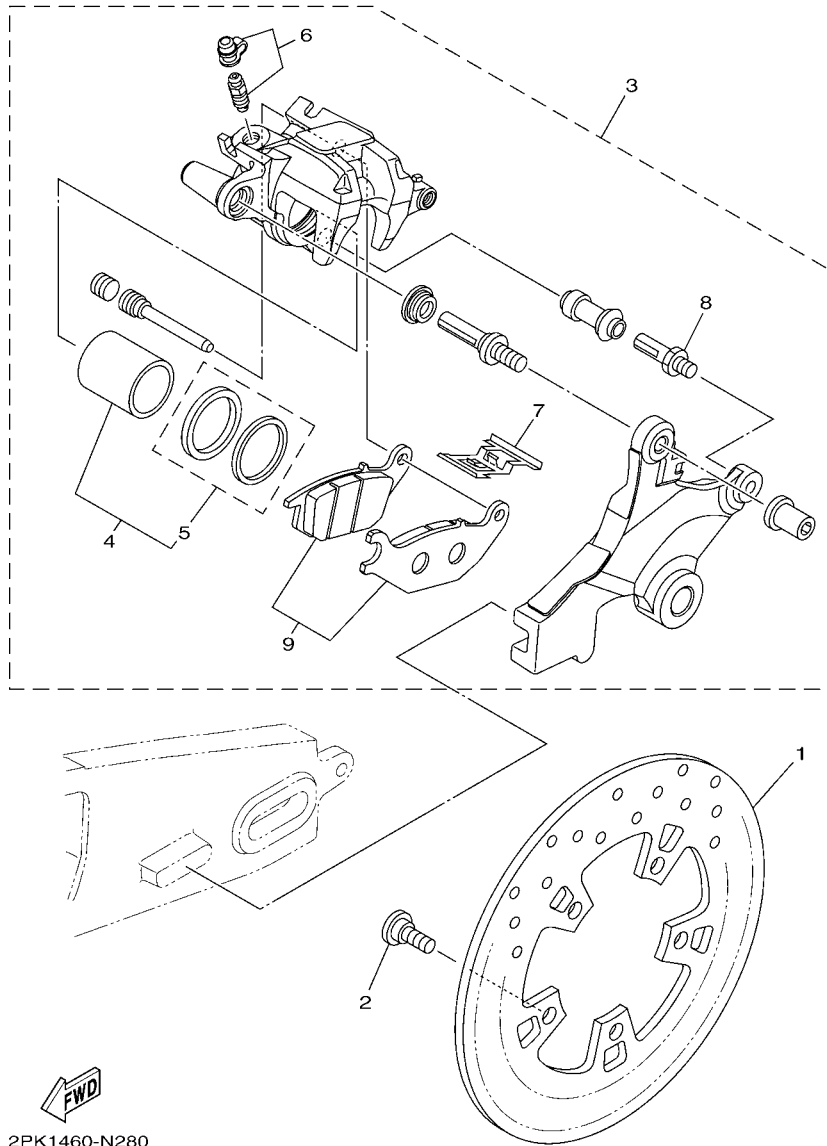

FIG. 27 RUEDA TRASERA

REAR WHEEL

REF. Nº	CODIGO Nº PART NO.	DESCRIPCION DESCRIPTION	B121			OBSERVACIONES REMARKS
26	1CK-F531B-10	EMBLEMA DE RUEDA EMBLEM, WHEEL	2			PARA BWC1 FOR BWC1



2PK1460-N280

FIG. 28 CALIBRE FRENO TRASERA REAR BRAKE CALIPER

REF. N°	CODIGO N° PART NO.	DESCRIPCION DESCRIPTION	B121			OBSERVACIONES REMARKS
1	1CK-F582W-00	DISCO DE FRENO TRASEROS 2 DISK, REAR BRAKE 2	1			
2	90109-08015	PERNO BOLT	5			
3	2FB-F580W-00	CALIBRE COMPLETO TRASEROS 2 CALIPER ASSY, REAR 2	1			
4	4S3-F5802-00	.PISTON COMPLETO PINZA .PISTON ASSY, CALIPER	1			
5	3GD-F5803-00	..JUEGO DE RETENES DE PINZA ..CALIPER SEAL KIT	1			
6	4S3-W0048-00	.CJTO TORNILLO DE PURGA .BLEED SCREW KIT	1			
7	4S3-F5919-00	.SOPORTE DE PASTILLAS .SUPPORT, PAD	1			
8	3SP-F5914-51	.PASADOR .PIN, SLIDE	1			
9	4S3-F5805-00	.JUEGO DE COJIN DE FRENO .BRAKE PAD KIT	1			

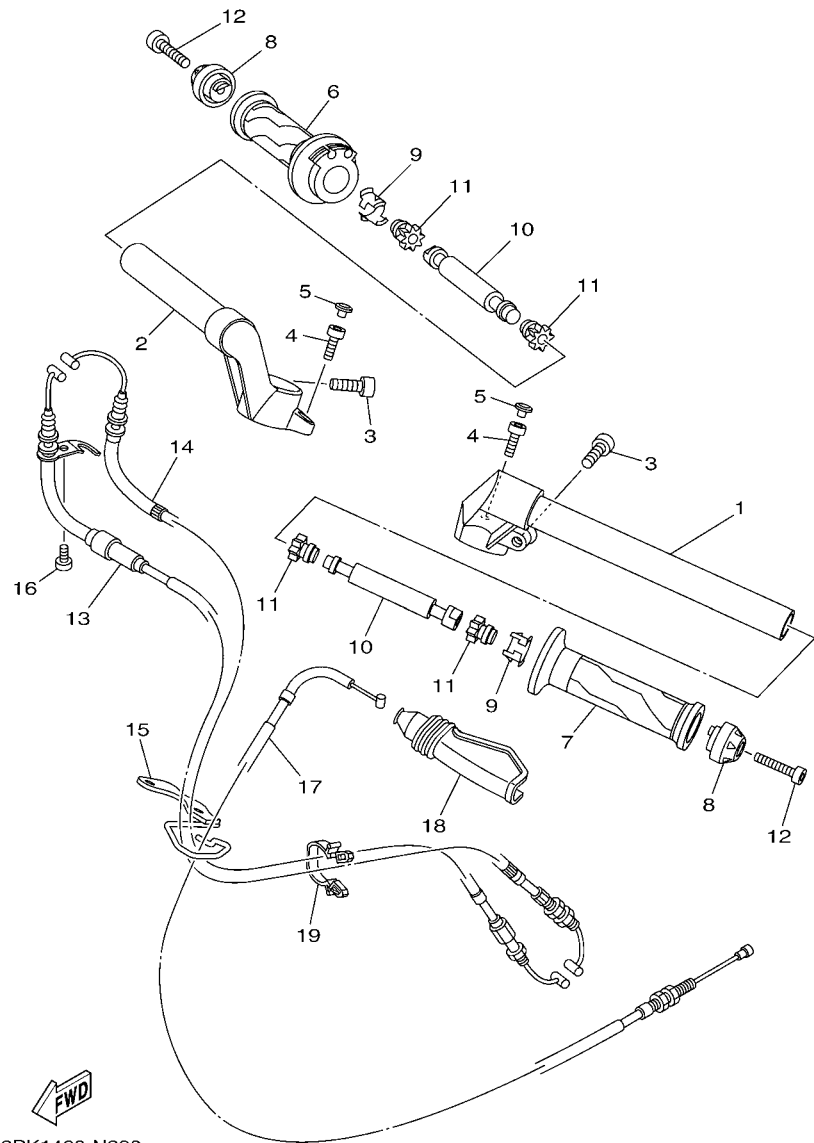

2PK1460-N290

FIG. 29 MANILLAR & CABLE

STEERING HANDLE & CABLE

REF. N°	CODIGO N° PART NO.	DESCRIPCION DESCRIPTION	B121				OBSERVACIONES REMARKS
1	20P-F6121-00	MANUBRIO (MI) HANDLEBAR (LEFT)	1				
2	20P-F6122-00	MANUBRIO (MD) HANDLEBAR (RIGHT)	1				
3	91317-08025	PERNO BOLT	2				
4	91317-06020	PERNO BOLT	2				
5	20P-F3469-00	TAPA DE PERNO CAP, BOLT	2				
6	1CK-F6240-00	EMPUNADURA COMPLETA GRIP ASSY	1				
7	20P-F6241-00	EMPUNADURA GRIP	1				
8	20P-F6246-00	EXTREMO DE EMPUNADURA END, GRIP	2				
9	20P-F6257-00	TOPE STOPPER	2				
10	20P-F622H-00	CONTRAPESO WEIGHT	2				
11	20P-F622F-00	AMORTIGUADOR, DE UBICACION 1 DAMPER, LOCATING 1	4				
12	91312-06030	TORNILLO BOLT	2				
13	2FB-F6311-00	CABLE DE ACELERADOR 1 CABLE, THROTTLE 1	1				
14	2FB-F6312-00	CABLE DE ACELERADOR 2 CABLE, THROTTLE 2	1				
15	20P-F6315-00	GUIA DE CABLE GUIDE, WIRE	1				
16	98507-05012	TORNILLO DE CABEZA PLANA SCREW, PAN HEAD	1				
17	20P-F6335-00	CABLE DE EMBRAGUE CABLE, CLUTCH	1				
18	20P-F6372-00	CUBIERTA DE PALANCA DE MANUB 1 COVER, HANDLE LEVER 1	1				
19	90464-24802	BRIDA CLAMP	1				

FIG. 30 CILINDRO MAESTRO DELANTERO FRONT MASTER CYLINDER

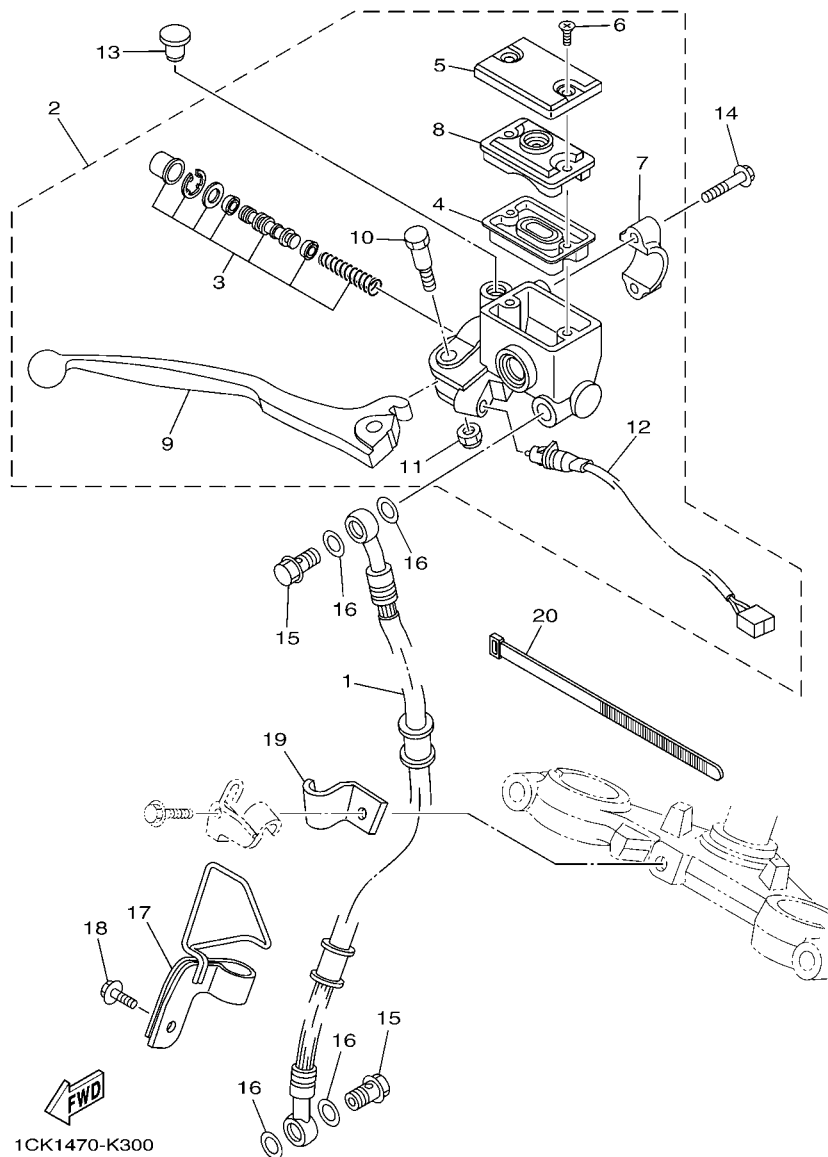

REF. Nº	CODIGO Nº PART NO.	DESCRIPCION DESCRIPTION	B121				OBSERVACIONES REMARKS
1	20P-F5872-00	MANGUERA DE FRENO 1 HOSE, BRAKE 1	1				
2	1CK-F583T-00	CILINDRO MAESTRO COMPLETO MASTER CYLINDER ASSY	1				
3	5P0-W0041-10	.JUEGO DE CILINDRO MAESTRO .CYLINDER KIT, MASTER	1				
4	3RW-F5854-00	.EMPAQUE, DIAFRAGMA .DIAPHRAGM, RESERVOIR	1				
5	3C1-F5852-00	.TAPA DE TANQUE DE RESERVA .CAP, RESERVOIR	1				
6	36Y-2589H-00	.TORNILLO .SCREW	2				
7	3RW-F5867-00	.SOPORTE DE CILINDRO MAESTRO .BRACKET, MASTER CYLINDER	1				
8	3C1-F5855-00	.BUJE DE DIAFRAGMA .BUSH, DIAPHRAGM	1				
9	38B-H3922-00	.PALANCA 2 .LEVER 2	1				
10	90109-06577	.PERNO .BOLT	1				
11	95602-06100	.TUERCA U .NUT, U	1				
12	1CK-H3980-00	.INTERRUP. DE PARADA DELANTERO .FRONT STOP SWITCH ASSY	1				
13	90338-09802	TAPON PLUG	1				
14	95027-06025	PERNO, DE BRIDA BOLT, FLANGE	2				
15	90401-10820	PERNO DE UNION BOLT, UNION	2				
16	90201-10118	ARANDELA PLANA WASHER, PLATE	4				
17	1CK-F5886-00	SOPORTE DE MANGUERA FRENO HOLDER, BRAKE HOSE	1				
18	95022-06014	PERNO, DE BRIDA BOLT, FLANGE	1				
19	20P-F5876-00	SOPORTE DE MANGUERA FRENO 2 HOLDER, BRAKE HOSE 2	1				
20	5TS-H3936-01	BANDA DE CABLE DE INTERRUPTOR BAND, SWITCH CORD	1				

FIG. 31 SOPORTE & APOYAPIE

STAND & FOOTREST

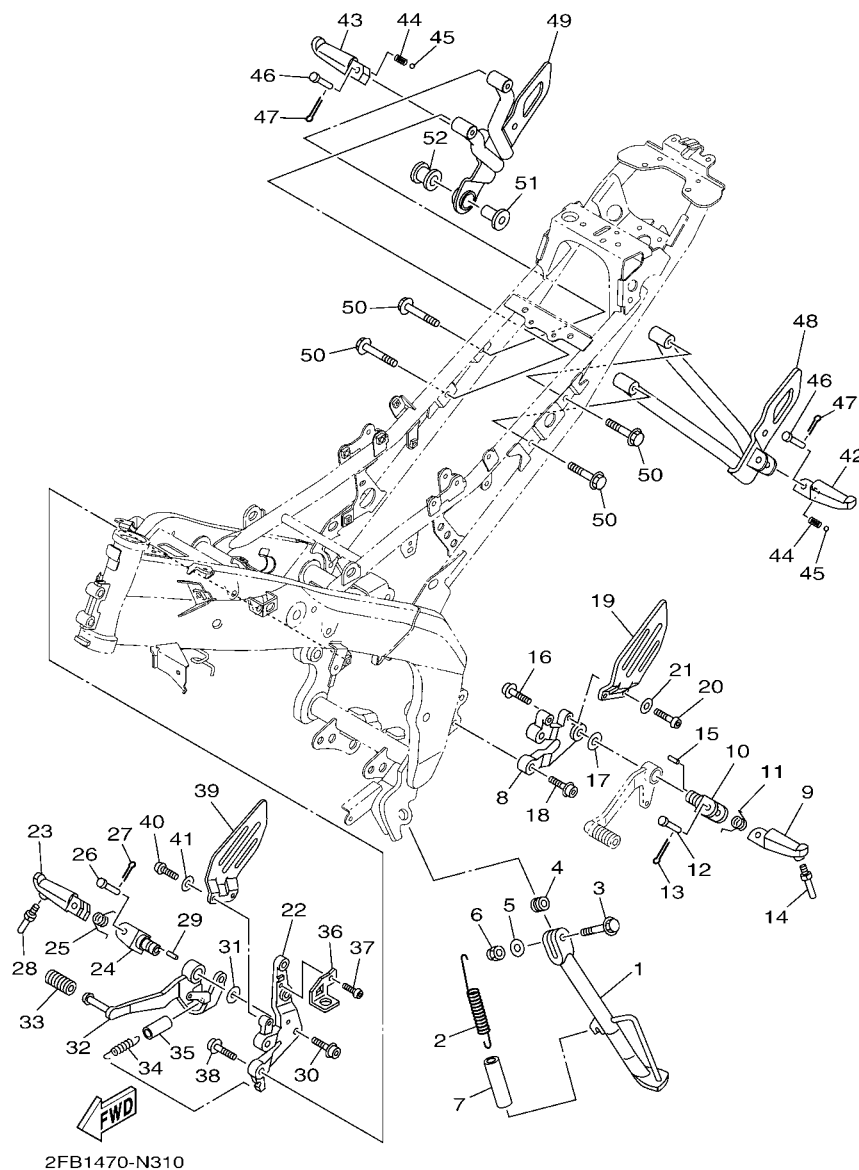

REF. Nº	CODIGO Nº PART NO.	DESCRIPCION DESCRIPTION	B121			OBSERVACIONES REMARKS
1	2FB-F7311-00	PUNTAL LATERAL STAND, SIDE	1			
2	90506-28800	RESORTE DE TENSION SPRING, TENSION	1			
3	90105-106A7	TORNILLO BOLT, FLANGE	1			
4	90387-10003	ESPACIADOR COLLAR	1			
5	92907-10600	ARANDELA WASHER, PLATE	1			
6	95617-10100	PERNO DE PUNTAL NUT, U	1			
7	90445-21848	TUBO (L70) HOSE (L70)	1			
8	20P-F7442-00	SOPORTE 2 BRACKET 2	1			
9	20P-F7451-00	APOYAPIE FOOTREST	1			
10	20P-F7411-00	APOYAPIE 1 FOOTREST 1	1			
11	90508-183B9	RESORTE DE TORSION SPRING, TORSION	1			
12	90240-08800	PASADOR CON HOYO PIN, CLEVIS	1			
13	91401-20012	CHAVETA PIN, COTTER	1			
14	20P-F7435-00	PERNO BOLT	1			
15	90249-02002	PASADOR PIN	1			
16	90110-10012	TORNILLO ALLEN BOLT, HEXAGON SOCKET HEAD	1			
17	90201-10066	ARANDELA PLANA WASHER, PLATE	1			
18	90110-08814	TORNILLO ALLEN BOLT, HEXAGON SOCKET HEAD	2			
19	2FB-F7445-00	PLACE 1 PLATE 1	1			
20	92012-06020	PERNO BOLT, BUTTON HEAD	2			
21	92902-06600	ARANDELA WASHER, PLATE	2			
22	20P-F7443-00	SOPORTE 3 BRACKET 3	1			
23	20P-F7461-00	APOYAPIE FOOTREST	1			
24	20P-F7411-00	APOYAPIE 1 FOOTREST 1	1			
25	90508-184B0	RESORTE DE TORSION SPRING, TORSION	1			
26	90240-08800	PASADOR CON HOYO PIN, CLEVIS	1			
27	91401-20012	CHAVETA PIN, COTTER	1			

FIG. 31 SOPORTE & APOYAPIE

STAND & FOOTREST

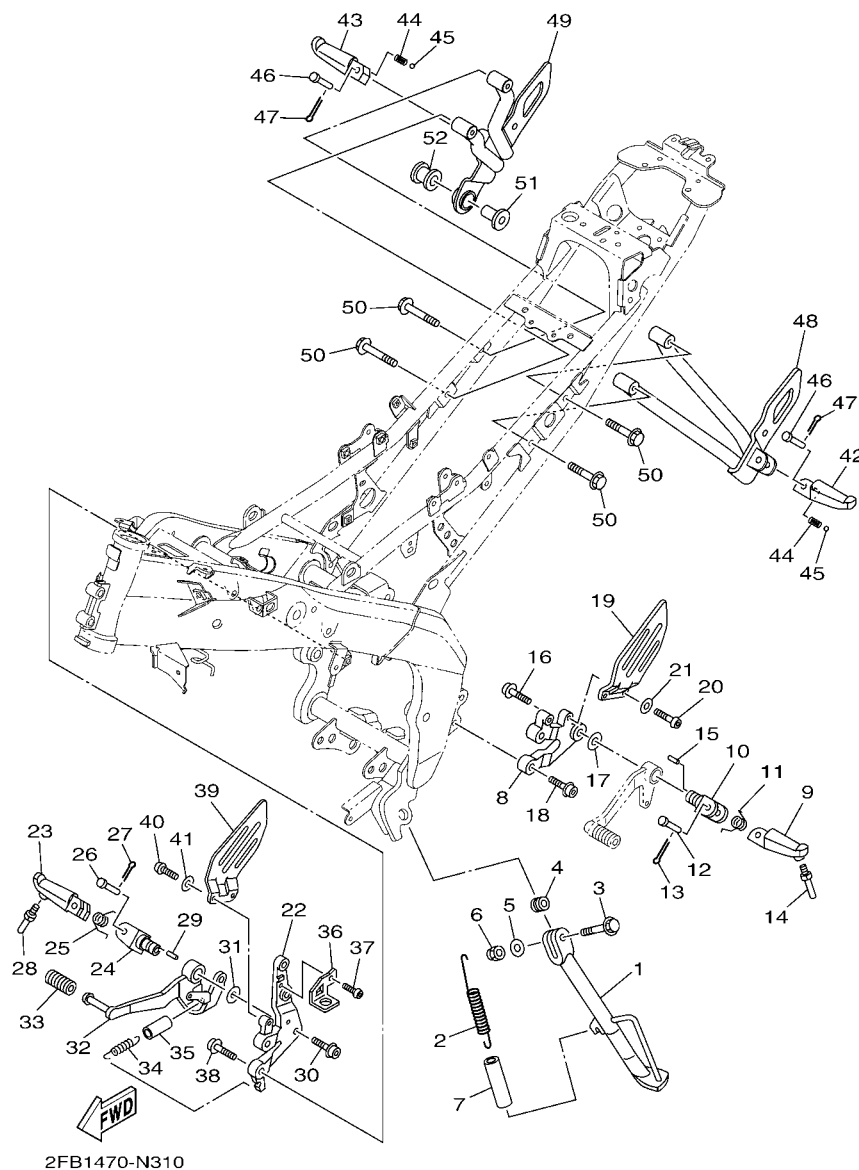

2FB1470-N310

REF. Nº	CODIGO Nº PART NO.	DESCRIPCION DESCRIPTION	B121				OBSERVACIONES REMARKS
28	20P-F7435-00	PERNO BOLT	1				
29	90249-02002	PASADOR PIN	1				
30	90110-10012	TORNILLO ALLEN BOLT, HEXAGON SOCKET HEAD	1				
31	90201-10066	ARANDELA PLANA WASHER, PLATE	1				
32	1CK-F7211-00	PEDAL DE FRENO PEDAL, BRAKE	1				
33	20P-E8113-00	FUNDA DEL PEDAL DEL CAMBIO COVER, SHIFT PEDAL	1				
34	90506-20193	RESORTE DE TENSION SPRING, TENSION	1				
35	90445-16807	TUBO HOSE	1				
36	1CK-F144G-00	SOPORTE DE INTERRUPTOR STAY, STOP SWITCH	1				
37	92012-06010	PERNO BOLT, BUTTON HEAD	1				
38	90110-08814	TORNILLO ALLEN BOLT, HEXAGON SOCKET HEAD	2				
39	2FB-F7446-00	PLACE 2 PLATE 2	1				
40	92012-06020	PERNO BOLT, BUTTON HEAD	2				
41	92902-06600	ARANDELA WASHER, PLATE	2				
42	20P-F7431-00	APOYAPIE POSTERIOR 1 FOOTREST, REAR 1	1				
43	20P-F7441-00	APOYAPIE POSTERIOR 2 FOOTREST, REAR 2	1				
44	90501-12743	RESORTE DE COMPRESION SPRING, COMPRESSION	2				
45	93501-04805	BOLA BALL	2				
46	90240-08800	PASADOR CON HOYO PIN, CLEVIS	2				
47	91401-20012	CHAVETA PIN, COTTER	2				
48	1CK-F741L-00	MENSULA 4 BRACKET 4	1				
49	1CK-F742L-00	MENSULA 5 BRACKET 5	1				
50	95812-08012	TORNILLO DE REBORDE BOLT, FLANGE	4				
51	90387-08812	ESPACIADOR COLLAR	1				
52	20P-E4747-00	AMORTIGUADOR DE SILENCIADOR DAMPER, MUFFLER	1				

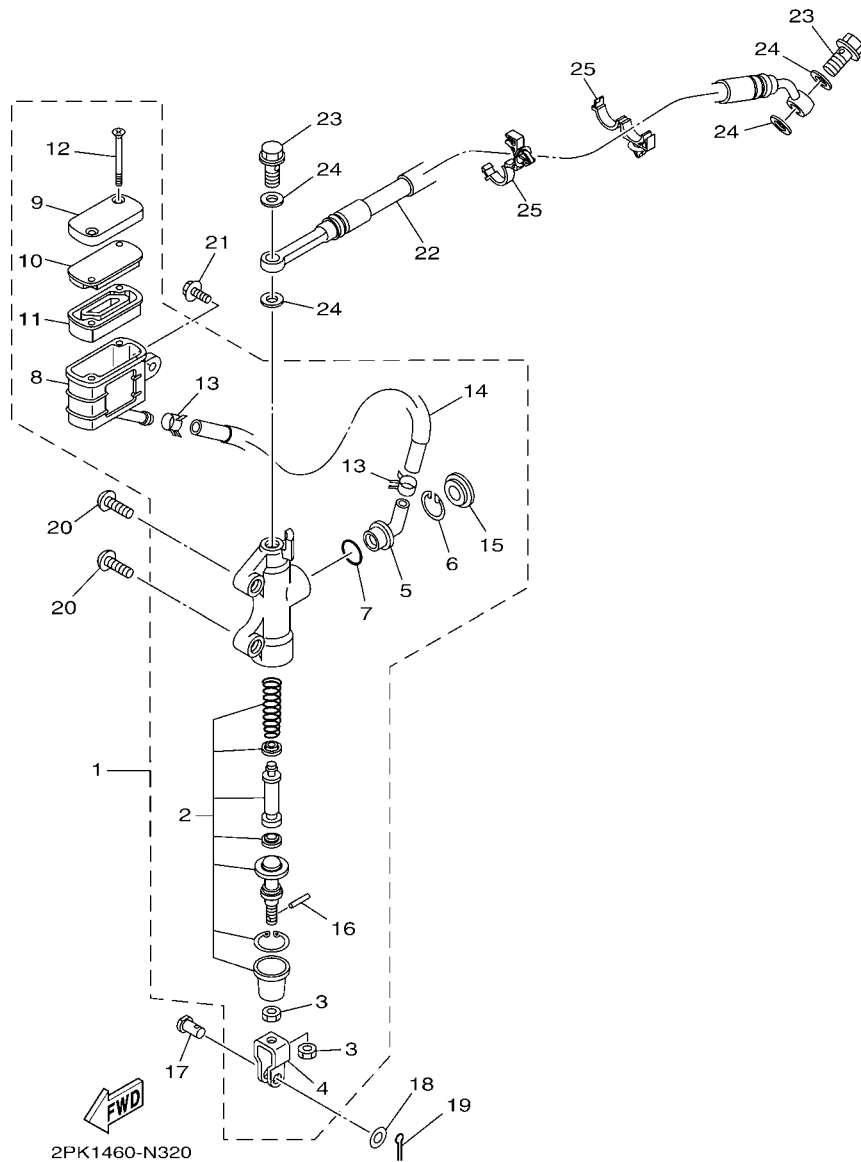
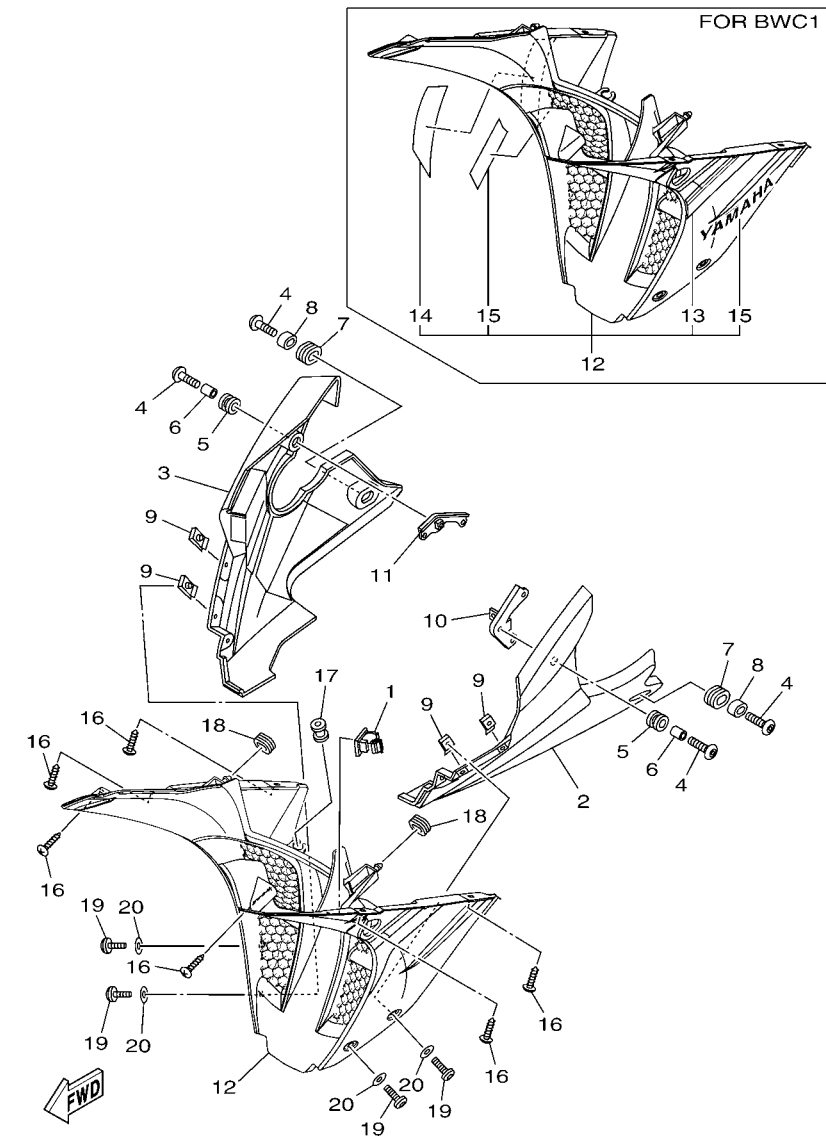

FIG. 32 CILINDRO MAESTRO TRASERO REAR MASTER CYLINDER

REF. N°	CODIGO N° PART NO.	DESCRIPCION DESCRIPTION	B121				OBSERVACIONES REMARKS
1	1CK-F583V-00	CILINDRO, MAESTRO TRASERO RR. MASTER CYLINDER ASSY.	1				
2	20P-W0042-00	.JUEGO DE CILINDRO MAESTRO .CYLINDER KIT, MASTER	1				
3	95301-08700	.TUERCA HEXAGONAL .NUT	2				
4	2YK-F7222-00	.UNION .JOINT	1				
5	4ML-F582A-50	.CONECTOR .JOINT	1				
6	2VN-F5866-00	.PRESILLA REDONDA .CIRCLIP	1				
7	93210-15620	.ANILLO O .O-RING	1				
8	20P-F5894-00	.TANQUE DE RESERVA .TANK, RESERVOIR	1				
9	54C-F5852-00	.TAPA DE TANQUE DE RESERVA .CAP, RESERVOIR	1				
10	20P-F585B-00	.PLACA, DIAFRAGMA .PLATE, DIAPHRAGM	1				
11	20P-F5854-00	.EMPAQUE, DIAFRAGMA .DIAPHRAGM, RESERVOIR	1				
12	98707-04045	.TORNILLO DE CABEZA PLANA .SCREW, FLAT HEAD	2				
13	90467-12085	.PRESILLA .CLIP	2				
14	1CK-F5895-00	.MANGUERA DE TANQUE DE RESERVA .HOSE, RESERVOIR	1				
15	3FV-F589A-00	.CUBIERTA PARA POLVO .COVER, DUST	1				
16	4TT-F7238-00	.PASADOR .PIN	1				
17	90240-08005	PASADOR CON HOYO PIN, CLEVIS	1				
18	90201-08066	ARANDELA PLANA WASHER, PLATE	1				
19	91401-20012	CHAVETA PIN, COTTER	1				
20	92012-08020	PERNO BOLT, BUTTON HEAD	2				
21	90119-06137	TORNILLO CON ARANDELA BOLT, WITH WASHER	1				
22	2FB-F5873-00	MANGUERA DE FRENO 2 HOSE, BRAKE 2	1				
23	90401-10820	PERNO DE UNION BOLT, UNION	2				
24	90201-10118	ARANDELA PLANA WASHER, PLATE	4				
25	90464-17003	BRIDA CLAMP	2				

FIG. 33 PATA PROTEGIDA

LEG SHIELD



B131700-P330

REF. Nº	CODIGO Nº PART NO.	DESCRIPCION DESCRIPTION	B121			OBSERVACIONES REMARKS
1	90464-05802	BRIDA CLAMP	1			
2	20P-F8385-10	CUBIERTA INFERIOR COVER, UNDER	1			
3	20P-F8395-11	CUBIERTA INFERIOR COVER, UNDER 2	1			
4	90111-06117	TORNILLO BOLT, HEX. SOCKET BUTTON	4			
5	90480-14003	TAPON GROMMET	2			
6	90387-068C2	ESPACIADOR COLLAR	2			
7	90480-01811	TAPON GROMMET	2			
8	20P-F1749-00	COLLAR COLLAR	2			
9	90183-050A7	TUERCA DE RESORTE NUT, SPRING	4			
10	54C-F831U-00	APOYO 1 STAY, SIDE 1	1			
11	20P-F832U-01	APOYO 1 STAY, SIDE 1	1			
12	1CK-F836M-00-P2	PANEL 3	1			S3 PARA DBNM8
	1CK-F836M-00-P1	PANEL 3	1			BWC1 PARA VRC1
	2FB-XF83D-00-P3	PANEL 3	1			DPBMY PARA BWC1
		PANEL, INNER 3	1			DPBMY FOR BWC1
13	2FB-F843G-00	.CALCOMANIA 3 .GRAPHIC, 3	1			PARA BWC1 FOR BWC1
14	2FB-F844G-00	.CALCOMANIA 4 .GRAPHIC, 4	1			PARA BWC1 FOR BWC1
15	99241-00140	.EMBLEMA, YAMAHA .EMBLEM, YAMAHA	2			PARA BWC1 FOR BWC1
16	97707-50012	TORNILLO SCREW, TRUSS HEAD TAPPING	6			
17	20P-F1773-00	ANILLO PROTECTOR GROMMET	1			
18	90480-01559	TAPON GROMMET	2			
19	90111-05003	TORNILLO BOLT, HEX. SOCKET BUTTON	4			
20	90202-05180	ARANDELA DE PLANA WASHER, PLATE	4			

FIG. 34 PARABRISAS

WINDSHIELD

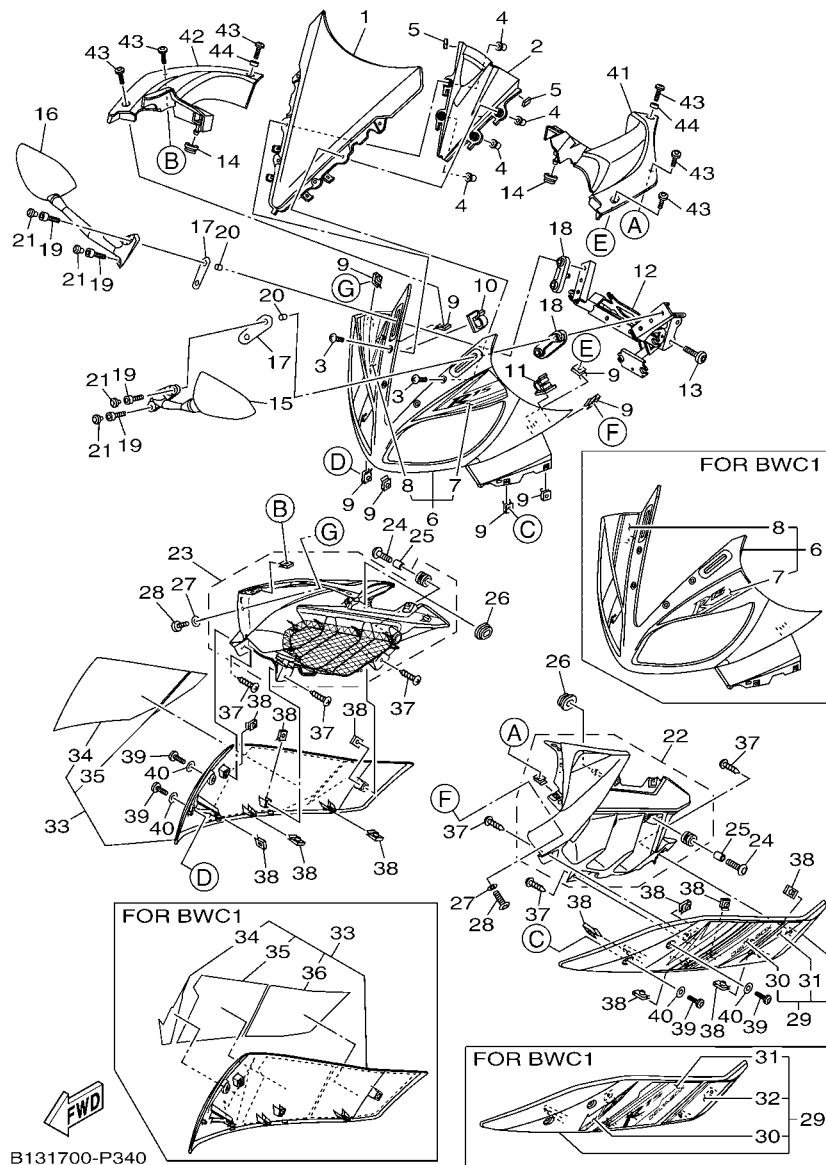

B131700-P340

REF. Nº	CODIGO Nº PART NO.	DESCRIPCION DESCRIPTION	B121			OBSERVACIONES REMARKS
1	1CK-F8381-00	PARABRISA WINDSHIELD	1			
2	20P-F836R-00	PANEL 5 PANEL, INNER 5	1			
3	90150-05024	TORNILLO CABEZA REDONDA SCREW, ROUND HEAD	4			
4	90179-05804	TUERCA NUT	4			
5	90520-02810	EQUILIBRIO, CUBIERTA DAMPER, PLATE	2			
6	2FB-XF835-00-P6	REFLECTOR PANEL ASSY	1			UR PARA DBNM8 UR FOR DBNM8
	2FB-XF835-10-P4	REFLECTOR PANEL ASSY	1			UR PARA VRC1 UR FOR VRC1
	2FB-XF835-20-P5	REFLECTOR PANEL ASSY	1			UR PARA BWC1 UR FOR BWC1
7	2FB-F841G-00	.CALCOMANIA DE BOVEDA 1 .GRAPHIC, 1	1			UR PARA DBNM8 UR FOR DBNM8
	2FB-F841G-10	.CALCOMANIA DE BOVEDA 1 .GRAPHIC, 1	1			UR PARA VRC1 UR FOR VRC1
	2FB-F841G-20	.CALCOMANIA DE BOVEDA 1 .GRAPHIC, 1	1			UR PARA BWC1 UR FOR BWC1
8	2FB-F842G-00	.EMBLEMA 2 .GRAPHIC, 2	1			UR PARA DBNM8 UR FOR DBNM8
	2FB-F842G-10	.EMBLEMA 2 .GRAPHIC, 2	1			UR PARA VRC1 UR FOR VRC1
	2FB-F842G-20	.EMBLEMA 2 .GRAPHIC, 2	1			UR PARA BWC1 UR FOR BWC1
9	90183-050A7	TUERCA DE RESORTE NUT, SPRING	8			
10	90464-20815	BRIDA CLAMP	1			
11	90464-05802	BRIDA CLAMP	1			
12	2FB-F8356-00	SOPORTE 1 STAY 1	1			
13	90111-08836	TORNILLO BOLT, HEX. SOCKET BUTTON	2			
14	90480-01558	TAPON GROMMET	2			
15	2PB-F6280-01	ESPEJO COMPLETO (IZQUIERDO) REAR VIEW MIRROR ASSY (LEFT)	1			
16	2PB-F6290-01	ESPEJO COMPLETO (DERECHO) REAR VIEW MIRROR ASSY (RIGHT)	1			
17	20P-F8483-00	PLACA 1 PLATE, RUBBER 1	2			
18	20P-F8484-00	PLACA 2 PLATE, RUBBER 2	2			
19	91317-06025	PERNO BOLT	4			
20	90387-068C2	ESPACIADOR COLLAR	4			
21	20P-F3469-00	TAPA DE PERNO CAP, BOLT	4			

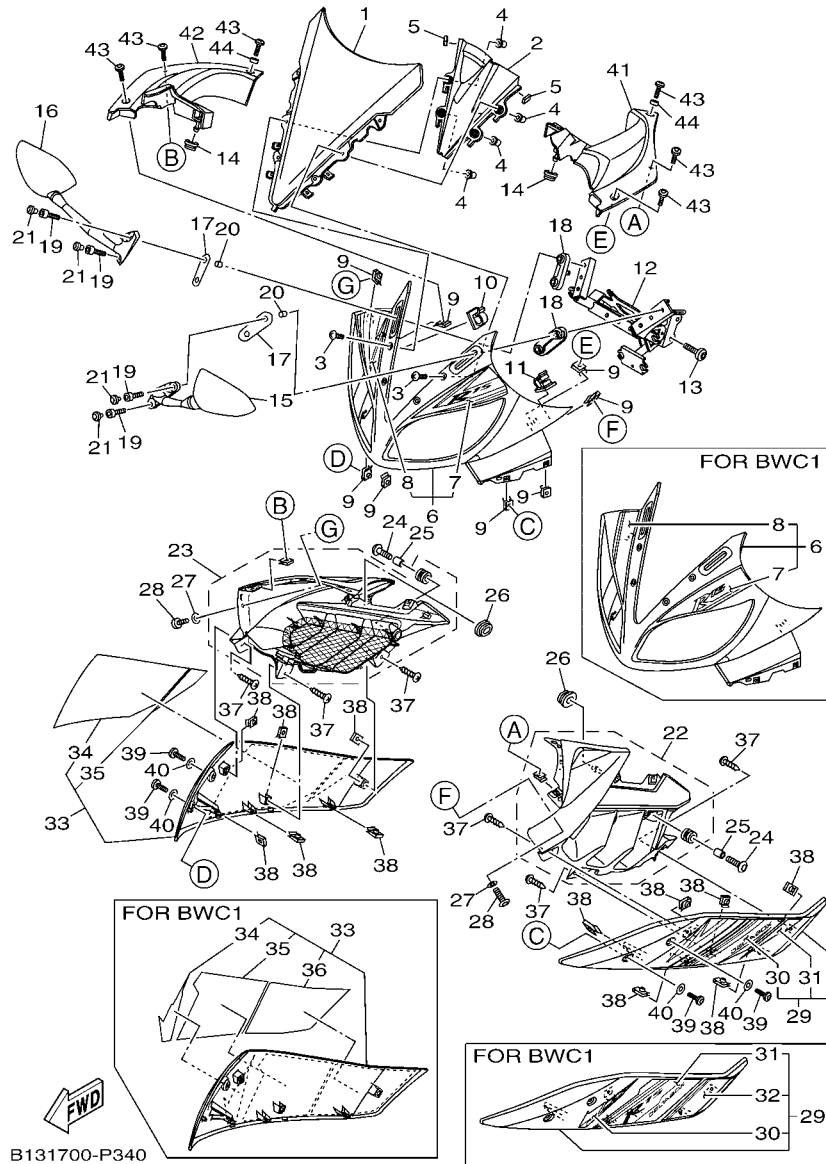

FIG. 34 PARABRISAS

WINDSHIELD

REF. Nº	CODIGO Nº PART NO.	DESCRIPCION DESCRIPTION	B121		OBSERVACIONES REMARKS
22	1CK-XF11E-20-P5	CUBIERTA 7 COVER 7	1		UR PARA DBNM8 UR FOR DBNM8
	1CK-XF11E-20-P2	CUBIERTA 7 COVER 7	1		UR PARA VRC1 UR FOR VRC1
	1CK-XF11E-30-P3	CUBIERTA 7 COVER 7	1		UR PARA BWC1 UR FOR BWC1
23	1CK-XF11F-20-P5	CUBIERTA 8 COVER 8	1		UR PARA DBNM8 UR FOR DBNM8
	1CK-XF11F-20-P2	CUBIERTA 8 COVER 8	1		UR PARA VRC1 UR FOR VRC1
	1CK-XF11F-30-P3	CUBIERTA 8 COVER 8	1		UR PARA BWC1 UR FOR BWC1
24	90111-06117	TORNILLO BOLT,HEX. SOCKET BUTTON	2		
25	90387-068C2	ESPACIADOR COLLAR	2		
26	90480-01558	TAPON GROMMET	2		
27	90202-05180	ARANDELA DE PLANA WASHER, PLATE	2		
28	90111-05003	TORNILLO BOLT,HEX. SOCKET BUTTON	2		
29	2FB-XF836-00-P6	PANEL COMPLETO 1 PANEL COMP 1	1		S3 PARA DBNM8 S3 FOR DBNM8
	2FB-XF836-10-P3	PANEL COMPLETO 1 PANEL COMP 1	1		BWC1 PARA VRC1 BWC1 FOR VRC1
	2FB-XF836-20-P0	PANEL COMPLETO 1 PANEL COMP 1	1		DPBMY PARA BWC1 DPBMY FOR BWC1
30	2FB-F8391-00	.CALCOMANIA 1 .GRAPHIC 1	1		UR PARA DBNM8 UR FOR DBNM8
	2FB-F8391-10	.CALCOMANIA 1 .GRAPHIC 1	1		UR PARA VRC1 UR FOR VRC1
	2FB-F8391-20	.CALCOMANIA 1 .GRAPHIC 1	1		UR PARA BWC1 UR FOR BWC1
31	2FB-F8393-00	.CALCOMANIA 3 .GRAPHIC 3	1		UR PARA DBNM8 UR FOR DBNM8
	2FB-F8393-10	.CALCOMANIA 3 .GRAPHIC 3	1		UR PARA VRC1 UR FOR VRC1
	2FB-F8393-20	.CALCOMANIA 3 .GRAPHIC 3	1		UR PARA BWC1 UR FOR BWC1
32	2FB-F8398-00	.GRAFICO 5 .GRAPHIC 5	1		PARA BWC1 FOR BWC1
33	2FB-XF83G-00-P6	PANEL COMPLETO 2 PANEL COMP 2	1		S3 PARA DBNM8 S3 FOR DBNM8
	2FB-XF83G-10-P3	PANEL COMPLETO 2 PANEL COMP 2	1		BWC1 PARA VRC1 BWC1 FOR VRC1
	2FB-XF83G-20-P0	PANEL COMPLETO 2 PANEL COMP 2	1		DPBMY PARA BWC1 DPBMY FOR BWC1
34	2FB-F8392-00	.CALCOMANIA 2 .GRAPHIC 2	1		UR PARA DBNM8 UR FOR DBNM8
	2FB-F8392-10	.CALCOMANIA 2 .GRAPHIC 2	1		UR PARA VRC1 UR FOR VRC1
	2FB-F8392-20	.CALCOMANIA 2 .GRAPHIC 2	1		UR PARA BWC1 UR FOR BWC1

FIG. 34 PARABRISAS

WINDSHIELD

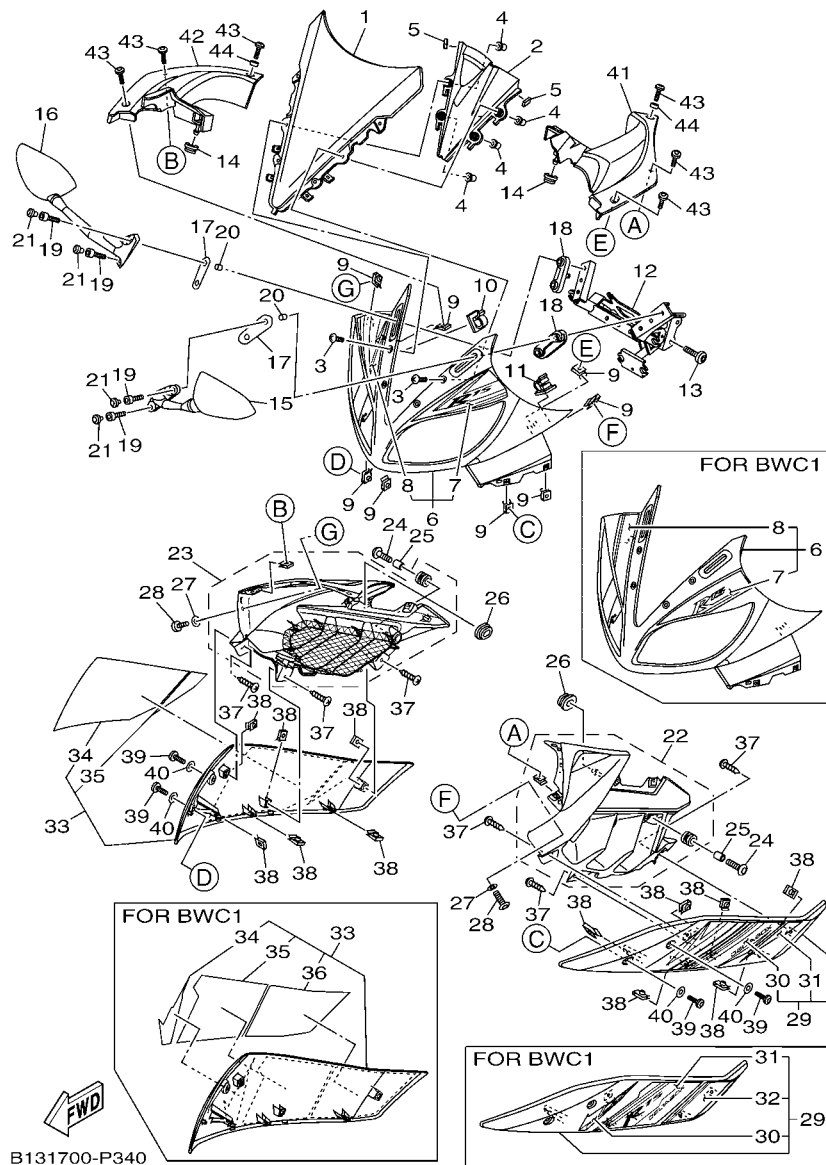

B131700-P340

REF. Nº	CODIGO Nº PART NO.	DESCRIPCION DESCRIPTION	B121			OBSERVACIONES REMARKS
35	2FB-F8394-00	.CALCOMANIA 4 .GRAPHIC 4	1			UR PARA DBNM8 UR FOR DBNM8
	2FB-F8394-10	.CALCOMANIA 4 .GRAPHIC 4	1			UR PARA VRC1 UR FOR VRC1
	2FB-F8394-20	.CALCOMANIA 4 .GRAPHIC 4	1			UR PARA BWC1 UR FOR BWC1
36	2FB-F8399-00	.CALCOMANIA 6 .GRAPHIC 6	1			PARA BWC1 FOR BWC1
37	97707-50012	TORNILLO SCREW, TRUSS HEAD TAPPING	6			
38	90183-05818	TUERCA DE RESORTE NUT, SPRING	12			
39	90111-05003	TORNILLO BOLT, HEX. SOCKET BUTTON	4			
40	90202-05180	ARANDELA DE PLANA WASHER, PLATE	4			
41	20P-F837L-00	PANEL DE CONSOLA PANEL, CONSOLE 1	1			
42	20P-F837M-00	PANEL, DE CONSOLA 2 PANEL, CONSOLE 2	1			
43	90111-05002	TORNILLO BOLT, HEX. SOCKET BUTTON	6			
44	90387-068C4	ESPACIADOR COLLAR	2			

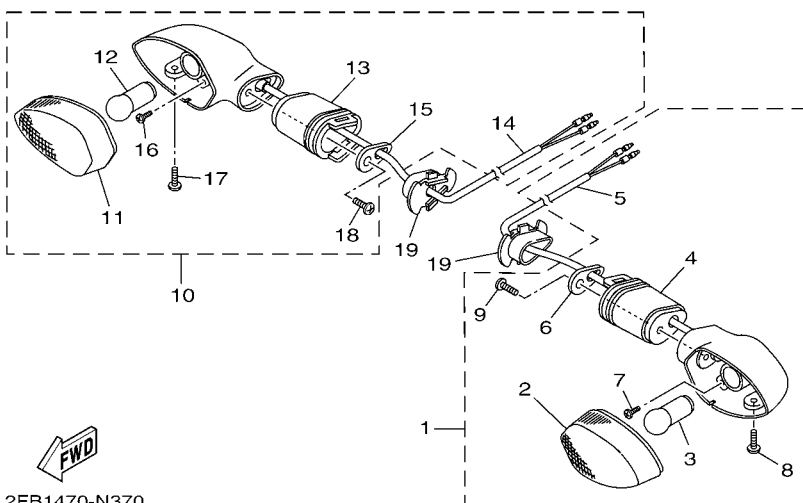
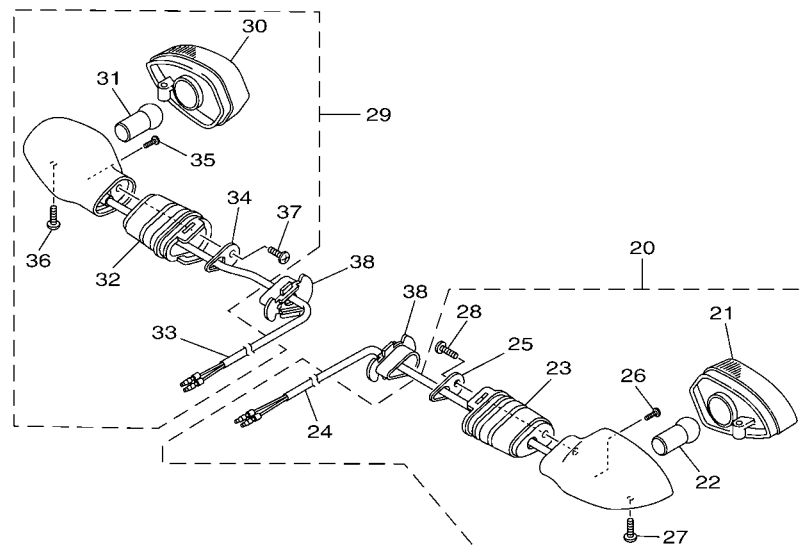
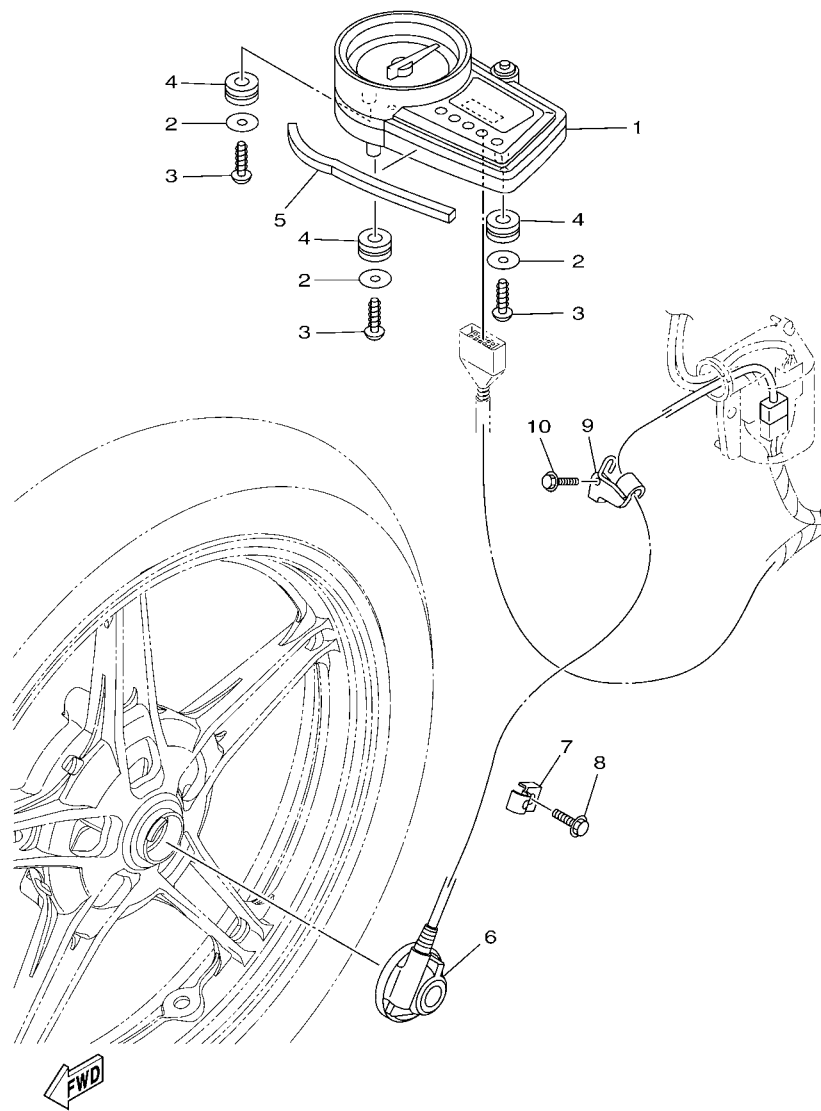

FIG. 37 LUZ DE DESTELLADOR FLASHER LIGHT

REF. Nº	CODIGO Nº PART NO.	DESCRIPCION DESCRIPTION	B121			OBSERVACIONES REMARKS
1	2FB-H3310-00	DESTELLADOR DE LUZ DELANT. FRONT FLASHER LIGHT ASSY 1	1			
2	54B-H331A-00	.LENTE COMPLETO 1 .LENS COMP 1	1			
3	2FB-H3311-00	.BOMBILLA (12V-10W) .BULB, FLASHER (12V-10W)	1			
4	20P-H3318-00	.SOPORTE DE DESTELLADOR 1 .STAY, FLASHER 1	1			
5	1CK-H331E-00	.CORDON COMPLETO .CORD ASSY	1			
6	20P-H3618-00	.PLACA .PLATE	1			
7	20P-H213A-00	.TORNILLO ACCESORIO .SCREW, FITTING	1			
8	20P-H3333-00	.TORNILLO ACCESORIO DE LENTE .SCREW, LENS FITTING	1			
9	20P-H2133-00	.TORNILLO ACCESORIO .SCREW, FITTING	1			
10	2FB-H3320-00	DESTELLADOR DE LUZ DELANT. FRONT FLASHER LIGHT ASSY 2	1			
11	54B-H332A-00	.LENTE COMPLETO 2 .LENS COMP 2	1			
12	2FB-H3311-00	.BOMBILLA (12V-10W) .BULB, FLASHER (12V-10W)	1			
13	20P-H3318-00	.SOPORTE DE DESTELLADOR 1 .STAY, FLASHER 1	1			
14	1CK-H332E-00	.CABLE COMPL. .CORD ASSY	1			
15	20P-H3618-00	.PLACA .PLATE	1			
16	20P-H213A-00	.TORNILLO ACCESORIO .SCREW, FITTING	1			
17	20P-H3333-00	.TORNILLO ACCESORIO DE LENTE .SCREW, LENS FITTING	1			
18	20P-H2133-00	.TORNILLO ACCESORIO .SCREW, FITTING	1			
19	5YY-H3318-10	SOPORTE DE DESTELLADOR 1 STAY, FLASHER 1	2			
20	2FB-H3330-00	DESTELLADOR DE LUZ TRAS.COMPL. REAR FLASHER LIGHT ASSY 1	1			
21	54B-H333A-00	.LENTE COMPLETO 1 .LENS COMP 1	1			
22	2FB-H3311-00	.BOMBILLA (12V-10W) .BULB, FLASHER (12V-10W)	1			
23	20P-H3318-10	.SOPORTE DE DESTELLADOR 1 .STAY, FLASHER 1	1			
24	1CK-H333E-00	.CABLE COMPLETA .CORD ASSY	1			
25	20P-H3618-00	.PLACA .PLATE	1			
26	20P-H213A-00	.TORNILLO ACCESORIO .SCREW, FITTING	1			
27	20P-H3333-00	.TORNILLO ACCESORIO DE LENTE .SCREW, LENS FITTING	1			



1CK1470-K380

FIG. 38 MEDIDOR

METER

REF. N°	CODIGO N° PART NO.	DESCRIPCION DESCRIPTION	B121				OBSERVACIONES REMARKS
1	2FB-H3500-00	METRO COMPLETO METER ASSY	1				
2	90201-05036	ARANDELA PLANA WASHER, PLATE	3				
3	97707-50016	TORNILLO SCREW, TRUSS HEAD TAPPING	3				
4	90480-14816	TAPON GROMMET	3				
5	20P-H3592-00	AMORTIGUADOR DAMPER	1				
6	1CK-H3755-01	SENSOR DE VELOCIDAD SENSOR, SPEED	1				
7	1CK-H3595-00	GRAMPA CLAMP	1				
8	95022-06012	PERNO, DE BRIDA BOLT, FLANGE	1				
9	1CK-H3596-00	GRAMPA CLAMP	1				
10	95022-06014	PERNO, DE BRIDA BOLT, FLANGE	1				

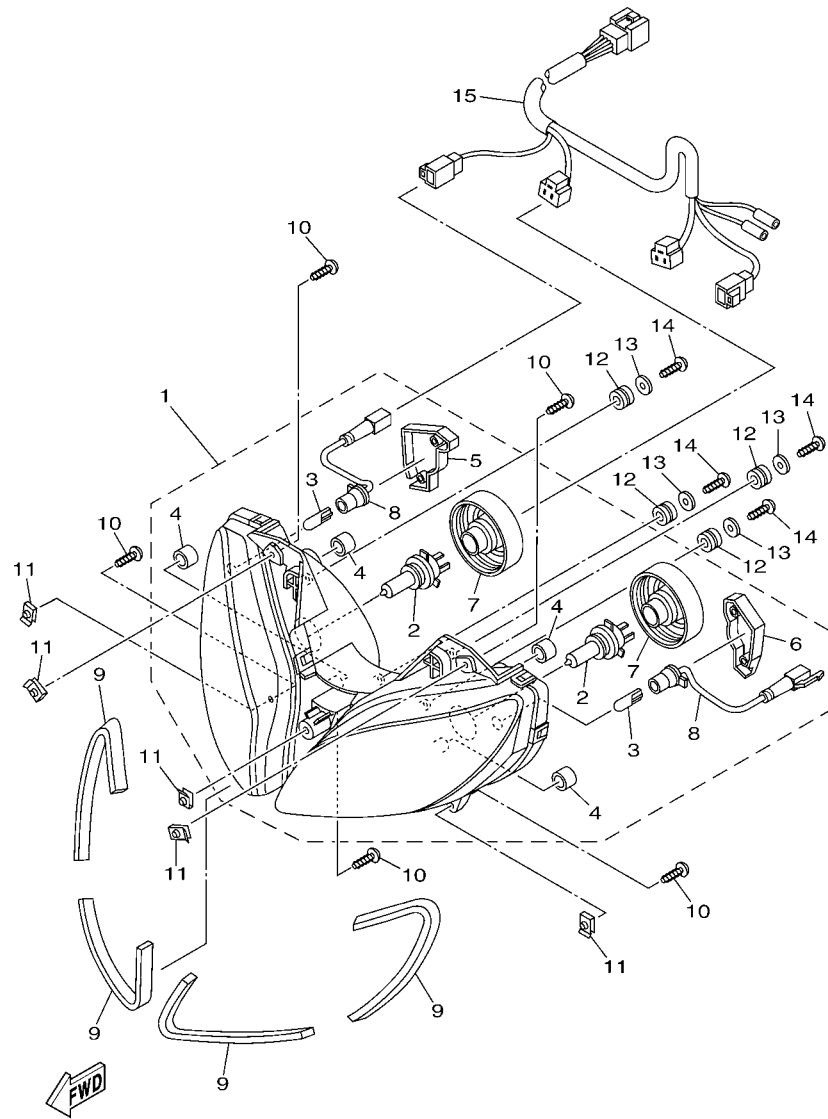

1CK1470-K391

FIG. 39 FARO DELANTERO

HEADLIGHT

REF. Nº	CODIGO Nº PART NO.	DESCRIPCION DESCRIPTION	B121				OBSERVACIONES REMARKS
1	54C-H4300-01	FARO DELANTERO COMPLETO HEADLIGHT ASSY	1				
2	20P-H4314-00	.AMPOLLETA (12V-35/35W) .BULB (12V-35/35W)	2				
3	20P-H4347-10	.AMPOLLETA (12V-5W) .BULB (12V-5W)	2				
4	20P-H4378-00	.TAPA .CAP	4				
5	20P-H4544-11	.CUBIERTA .COVER	1				
6	20P-H4544-01	.CUBIERTA .COVER	1				
7	20P-H4397-00	.CUBIERTA DE ENCASTRE .COVER, SOCKET	2				
8	20P-H4312-01	.CABLE COMPLETA .CORD ASSY	2				
9	20P-H4345-00	AMORT DE FARO DELANTERO DAMPER, HEADLIGHT	4				
10	97707-50016	TORNILLO SCREW, TRUSS HEAD TAPPING	5				
11	90183-05818	TUERCA DE RESORTE NUT, SPRING	5				
12	90480-14229	TAPON GROMMET	4				
13	90201-05036	ARANDELA PLANA WASHER, PLATE	4				
14	97707-50016	TORNILLO SCREW, TRUSS HEAD TAPPING	4				
15	2PB-H4359-00	CABLE DE FARO DELANTERO CORD, HEADLIGHT	1				

FIG. 40 LUZ DE COLA

TAILLIGHT

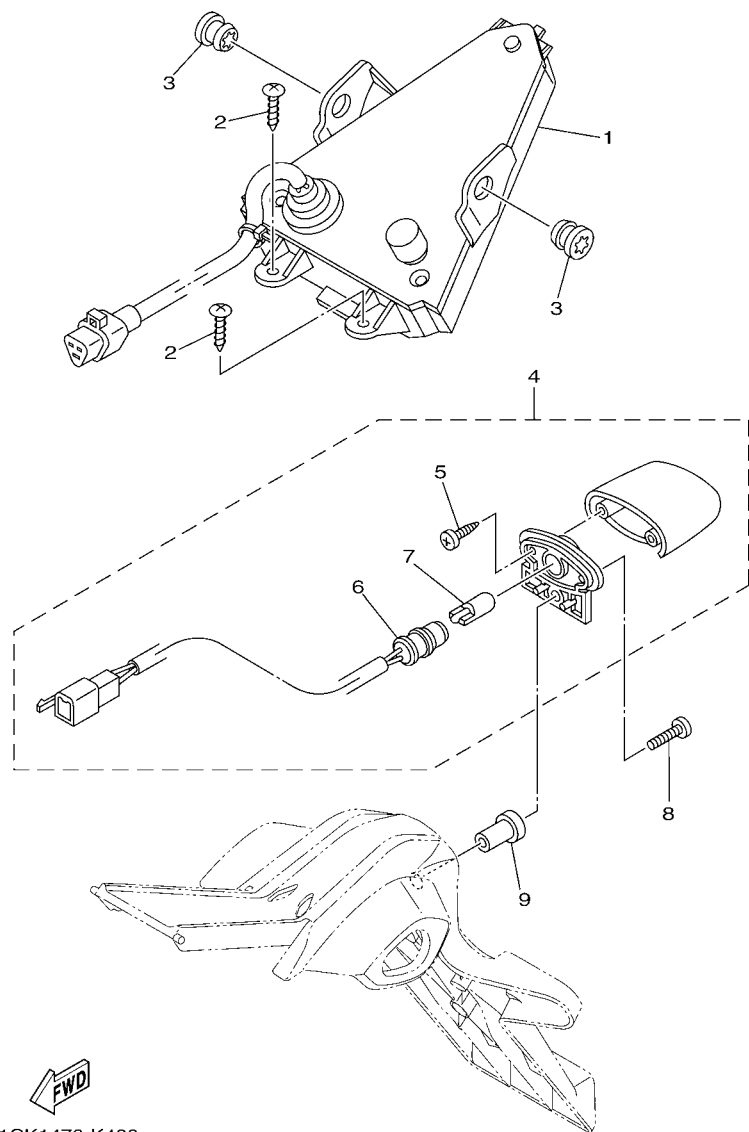

1CK1470-K400

REF. Nº	CODIGO Nº PART NO.	DESCRIPCION DESCRIPTION	B121				OBSERVACIONES REMARKS
1	1CK-H4710-00	UNIDAD FARO TRASERO COMPL. TAILLIGHT UNIT ASSY	1				
2	97702-50014	TORNILLO ROSCA HEMBRA SCREW, TAPPING	2				
3	90480-13818	TAPON GROMMET	2				
4	1CK-H4740-00	LUZ DE LICENCIA COMPLETA LICENCE LIGHT ASSY	1				
5	1CK-H4726-00	TORNILLO SCREW	2				
6	1CK-H4547-00	CABLE DE LUZ DE LICENCIA .CORD, LICENCE LIGHT	1				
7	1CK-H4744-00	BOMBILLA (12V-5W) BULB (12V-5W)	1				
8	98907-04020	TORNILLO DE LIGAR SCREW, BIND	1				
9	90179-04003	TUERCA NUT	1				

FIG. 41 INTERRUPTOR DE MANILLAR&PALANC HANDLE SWITCH & LEVER

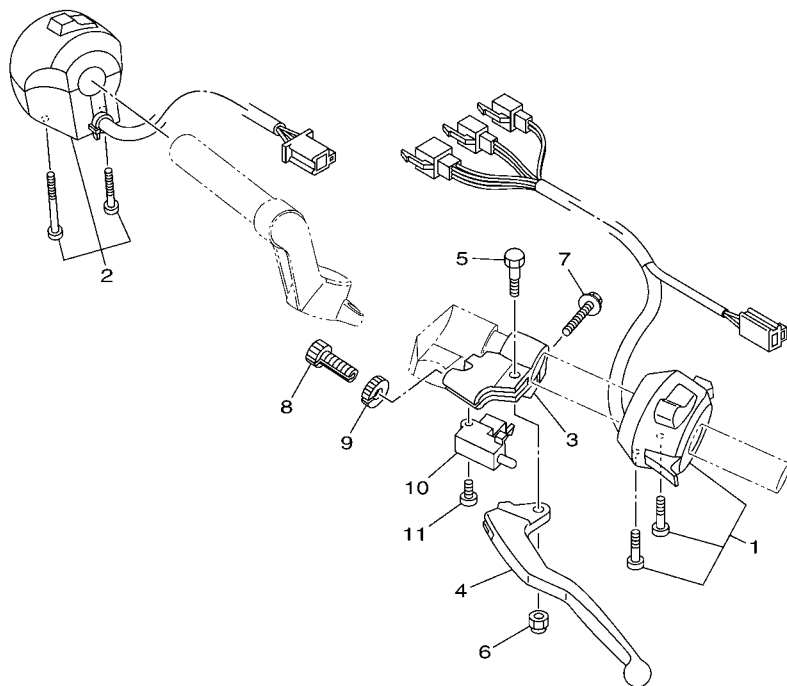

REF. Nº	CODIGO Nº PART NO.	DESCRIPCION DESCRIPTION	B121				OBSERVACIONES REMARKS
1	20P-H3972-01	INTERRUPTOR DE MANIJA 4 SWITCH, HANDLE 4	1				
2	2PB-H3975-00	INTERRUPTOR DE MANIJA 2 SWITCH, HANDLE 2	1				EXCEPT PARA AGO EXCEPT FOR AGO PARA AGO FOR AGO
	1CK-H3963-00	INTERRUPTOR DE MANIJA 3 SWITCH, HANDLE 3	1				
3	20P-H2911-00	SOPORTE DE LEVA 1 HOLDER, LEVER 1	1				
4	20P-H3912-00	PALANCA 1 LEVER 1	1				
5	20P-H3945-00	PERNO DE PALANCA BOLT, LEVER	1				
6	20P-H331B-00	TUERCA DE RESORTE NUT, SPRING	1				
7	20P-H3546-00	PERNO BOLT	1				
8	20P-H3951-00	PERNO DE CABLE DE AJUSTE BOLT, CABLE ADJUSTING	1				
9	20P-H3927-00	TUERCA DE AJUSTE NUT, ADJUSTING	1				
10	3YX-82917-01	INTERRUPTOR SWITCH	1				
11	98707-03020	TORNILLO DE CABEZA PLANA SCREW, FLAT HEAD	1				

2PB2700-M410

FIG. 42 EQUIPO ELECTRICO 1

ELECTRICAL 1

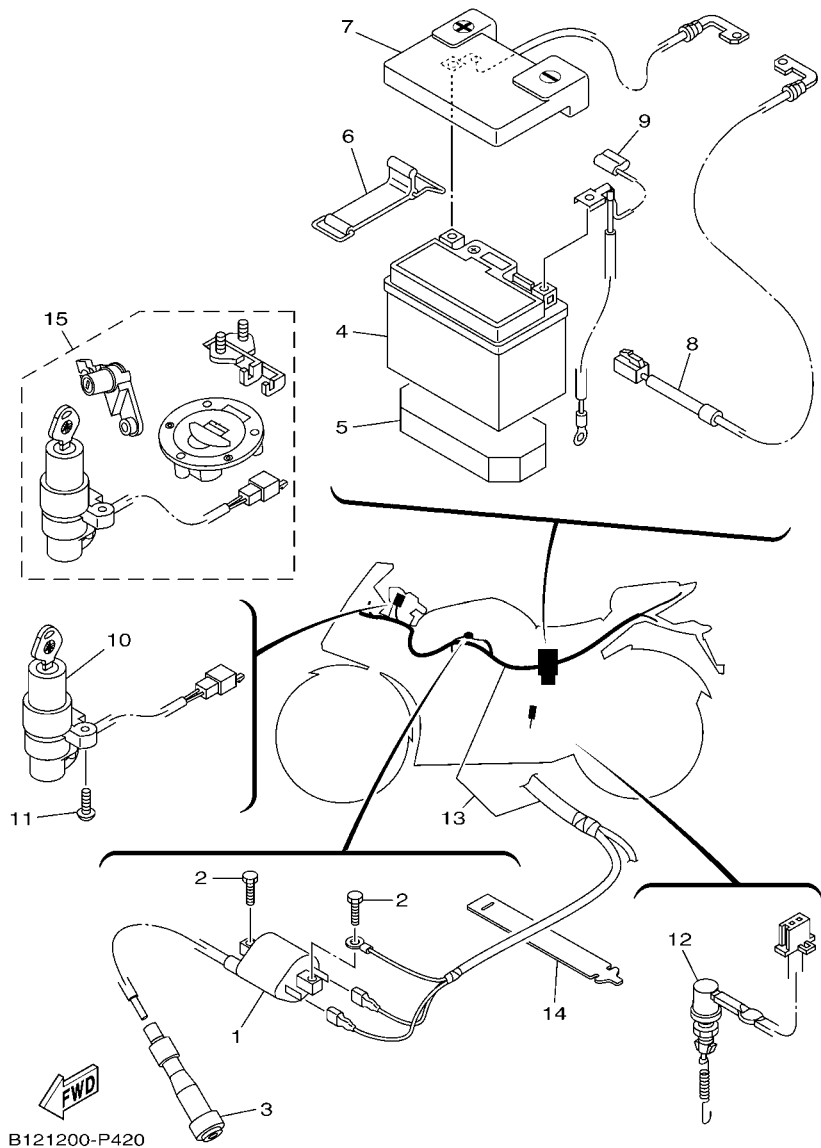

REF. Nº	CODIGO Nº PART NO.	DESCRIPCION DESCRIPTION	B121				OBSERVACIONES REMARKS
1	1P5-H2310-10	BOBINA DE ENCENDIDO COMPLETA IGNITION COIL ASSY	1				
2	97002-06016	PERNO BOLT, HEXAGON	2				
3	20P-H2370-02	TAPON DE BUJIA COMPLT PLUG CAP ASSY	1				
4	20P-H2100-00	BATERIA COMPLETA(GS YTZ5S MF) BATTERY ASSY (GS YTZ 5S MF)	1				
5	1CK-H2121-00	BASE DE BATERIA PAD, BATTERY	1				
6	20P-F811G-00	CINTA BAND	1				
7	1CK-H2115-00	CABLE CONDUCTOR POSITIVO WIRE, PLUS LEAD	1				
8	1CK-H2509-00	CABLE SUBCONDUCTOR WIRE, SUB LEAD	1				
9	1CK-H2116-00	CABLE CONDUCTOR NEGATIVO WIRE, MINUS LEAD	1				
10	54C-H2501-00	LLAVE DE IGNICION COMPLT MAIN SWITCH STEERING LOCK	1				
11	90149-06118	TORNILLO DE REGLAJE SCREW	2				
12	1CK-H2530-00	INTERRUPTOR DE PARADA COMPLETO STOP SWITCH ASSY	1				
13	2FB-H2590-00	CONJUNTO DE CABLES WIRE HARNESS ASSY	1				
14	2FB-F179E-00	BANDA BAND	1				
15	2FB-XH250-00	LLAVE DE IGNICION COMPLT MAIN SW. STRG. LOCK SUB ASSY	1				AP AP

FIG. 43 EQUIPO ELECTRICO 2

ELECTRICAL 2

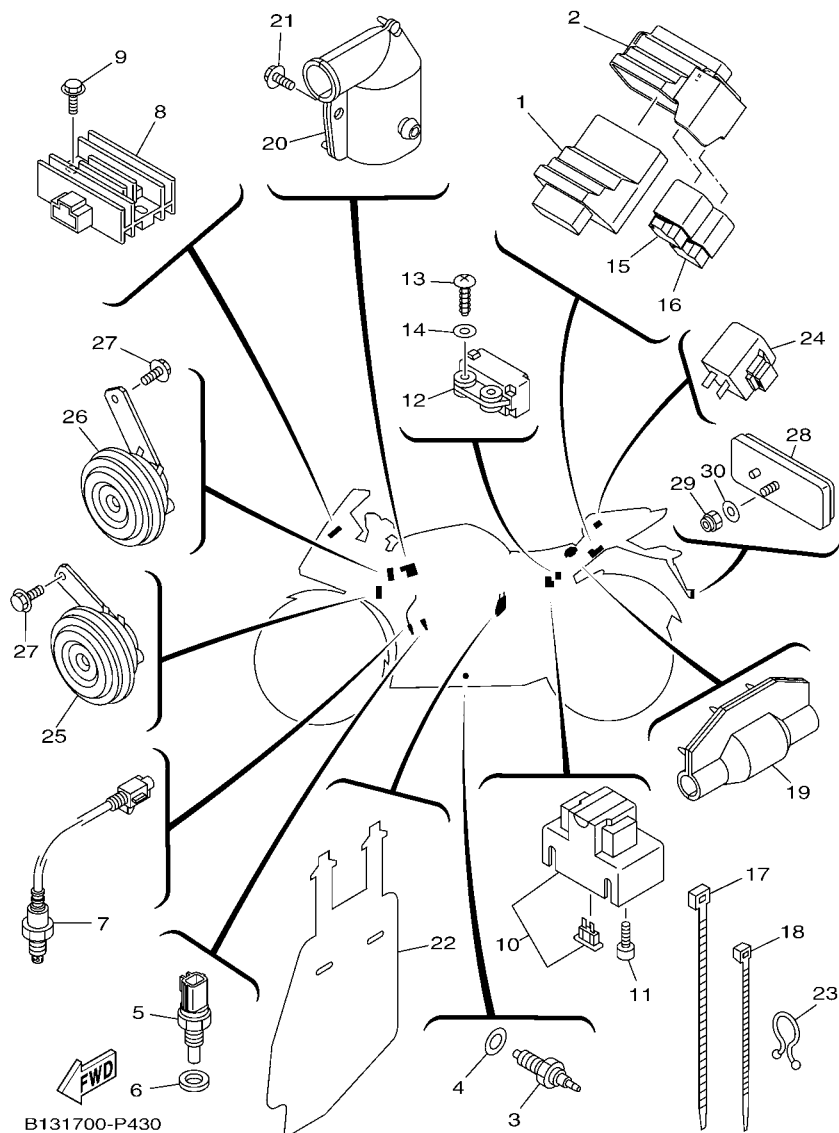

REF. Nº	CODIGO Nº PART NO.	DESCRIPCION DESCRIPTION	B121				OBSERVACIONES REMARKS
1	2FB-H591A-00	UNIDAD CONTROL ENGINE CONTROL UNIT ASSY	1				
2	2FB-H5546-00	BANDA BAND	1				
3	21C-H2540-00	INTERRUPTOR NEUTRAL COMPL NEUTRAL SWITCH ASSY	1				
4	90430-10148	JUNTA GASKET	1				
5	52B-H3591-00	UNIDAD TERMOSTATO THERMO UNIT	1				
6	90430-10802	JUNTA GASKET	1				
7	2FB-H592A-00	SENSOR SENSOR, OXYGEN	1				
8	54B-H1960-00	RECTIFICADOR Y REGULADOR RECTIFIER & REGULATOR ASSY	1				
9	95802-06020	TORNILLO DE REBORDE BOLT, FLANGE	2				
10	1CK-H1940-01	CONJUNTO ARRANCADOR RELEVO STARTER RELAY ASSY	1				
11	91312-05008	TORNILLO BOLT	2				
12	10B-82576-00	SENSOR ANGULO DE INCLINACION SENSOR, LEAN ANGLE	1				
13	97702-40012	TORNILLO ROSCA HEMBRA SCREW, TAPPING	2				
14	90201-047A2	ARANDELA PLANA WASHER, PLATE	2				
15	2FB-H1950-00	RELE COMPLETO RELAY ASSY	1				
16	1CK-H1950-01	RELE COMPLETO RELAY ASSY	1				
17	90464-50800	BRIDA CLAMP	3				
18	90464-36800	BRIDA CLAMP	6				
19	1CK-H2599-01	CUBIERTA DE CONECTOR COVER, CONNECTER	1				
20	20P-H246B-02	CUBIERTA 1 COVER 1	1				
21	90119-06054	TORNILLO CON ARANDELA BOLT, WITH WASHER	1				
22	1CK-H2589-01	PROTECTOR DE ARNES DE CABLE PROTECTER, WIRE HARNESS	1				
23	90464-20822	BRIDA CLAMP	2				
24	5TS-H3350-01	RELE DE DESTELLADOR COMPL. FLASHER RELAY ASSY	1				
25	1CK-H3371-10	BOCINA HORN	1				
26	1CK-H3371-00	BOCINA HORN	1				
27	95822-06012	TORNILLO DE REBORDE BOLT, FLANGE	2				

FIG. 43 EQUIPO ELECTRICO 2

ELECTRICAL 2

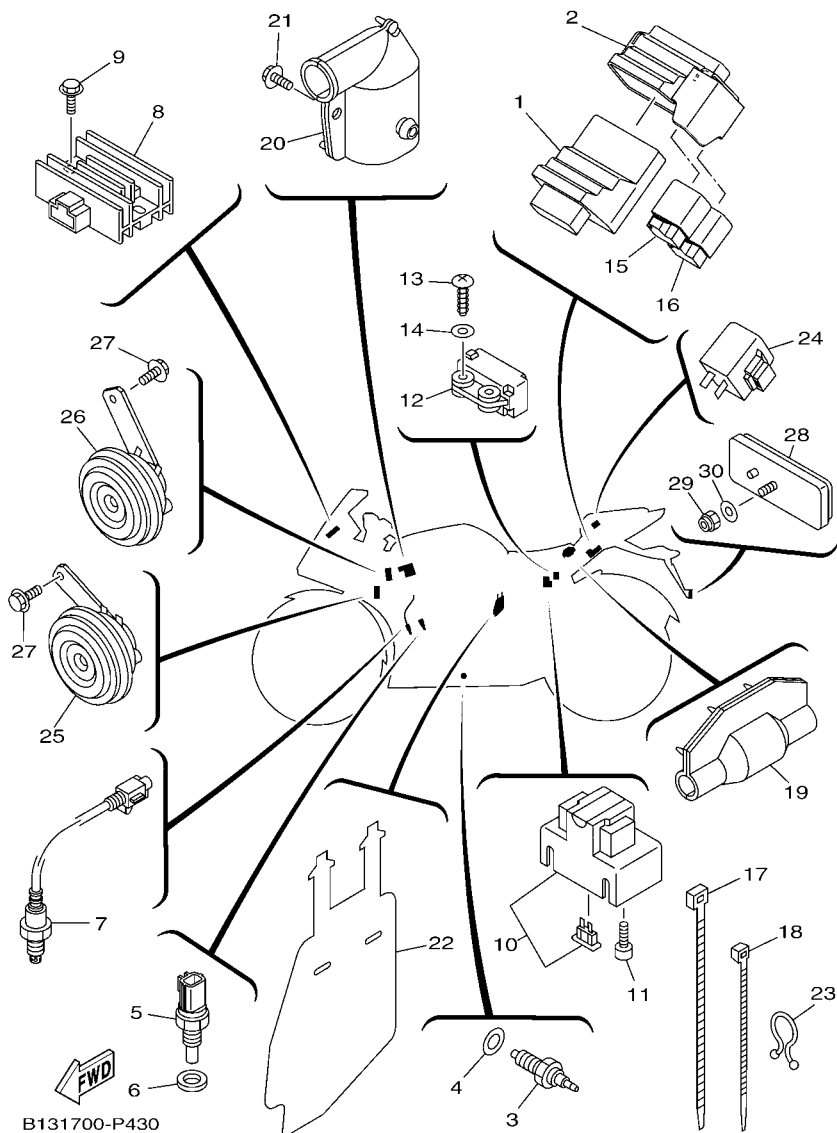

B131700-P430

REF. Nº	CODIGO Nº PART NO.	DESCRIPCION DESCRIPTION	B121				OBSERVACIONES REMARKS
28	5US-H5110-00	REFLECTOR COMPLETO REFLECTOR ASSY	1				
29	95602-05100	TUERCA U NUT, U	1				
30	90201-05725	ARANDELA PLANA WASHER, PLATE	1				

INDICE NUMERICO
NUMERICAL INDEX

CODIGO Nº PART NO.	REF. Nº	CODIGO Nº PART NO.	REF. Nº	CODIGO Nº PART NO.	REF. Nº	CODIGO Nº PART NO.	REF. Nº	CODIGO Nº PART NO.	REF. Nº	CODIGO Nº PART NO.	REF. Nº
1WG-12118-00	3 - 5	38B-E2210-00	4 - 16	20P-E4485-00	8 - 21	38B-E7241-00	14 - 18	2FB-F179E-00	42 - 14	20P-F3170-00	22 - 9
2DM-12159-00	3 - 9	1CK-E2213-00	4 - 17	21C-E4613-00	9 - 12	38B-E7251-00	14 - 15	20P-F1823-00	19 - 15		22 - 28
	3 - 12	38B-E2231-00	4 - 11	2FB-E4703-00	9 - 1	38B-E7258-00	14 - 14	20P-F1828-00	19 - 11	20P-F3173-00	22 - 12
183-23411-00	21 - 2	38B-E2241-00	4 - 12	1CK-E4718-00	9 - 2	38B-E7261-00	14 - 20	2FB-F1871-00	19 - 8		22 - 31
183-23412-00	21 - 3	38B-E2256-00	4 - 15	1CK-E4728-00	9 - 3	1CK-E7402-00	14 - 12	20P-F1875-00	19 - 10	21C-F3181-10	22 - 14
5TL-2341E-00	21 - 4	1PA-E2280-00	4 - 5	20P-E4747-00	31 - 52	38B-E7411-01	14 - 1	1CK-F2110-00	20 - 1		22 - 33
5MT-25398-00	25 - 7	2FB-E2288-00	4 - 6	1CK-E4799-00	9 - 8	4LS-E7456-00	14 - 28	1CK-F2128-00	20 - 4	20P-F3340-00	22 - 40
	27 - 15	5YP-E2405-00	6 - 5	2FB-E5113-00	11 - 9	38B-E7471-00	14 - 10	20P-F2141-00	20 - 5	20P-F3346-00	22 - 41
5MT-25398-10	25 - 7	38B-E240A-00	6 - 4	2FB-E5150-00	10 - 1	38B-E8101-00	16 - 4	1CK-F2147-00	20 - 24	20P-F3416-00	21 - 5
	27 - 15	1CK-E2411-00	6 - 1	38B-E5351-00	7 - 3	20P-E8111-01	16 - 9	1CK-F2151-00	20 - 7	20P-F3418-00	21 - 8
5MT-25398-20	25 - 7	38B-E2413-00	6 - 2	38B-E5362-00	11 - 17	20P-E8112-01	16 - 14	1CK-F217A-00	20 - 10	20P-F3435-00	21 - 9
	27 - 15	38B-E2422-00	5 - 1	2FB-E5411-00	11 - 1	20P-E8113-00	16 - 10	2PK-F217F-00	20 - 14	5YY-F3462-00	22 - 43
36Y-2589H-00	30 - 6	38B-E2428-00	5 - 3	38B-E5418-00	11 - 10		31 - 33	20P-F2184-00	20 - 3	20P-F3469-00	29 - 5
5D7-8183G-00	36 - 3	38B-E2443-00	5 - 13	1CK-E5421-00	11 - 12	20P-E8115-01	16 - 11	1CK-F219X-00	20 - 20		34 - 21
10B-82576-00	43 - 12	38B-E2450-01	5 - 7	38B-E5441-00	4 - 18	21C-E8140-00	16 - 1	1CK-F2210-00	20 - 27	1CK-F3738-00	22 - 20
3YX-82917-01	41 - 10	20P-E2467-01	6 - 15	2FB-E5451-00	11 - 2	38B-E8337-00	16 - 3	1CK-F2311-00	20 - 17		22 - 39
2FB-E1102-00	1 - 1	1CK-E246A-00	6 - 14	2FB-E5461-00	11 - 13	38B-E8511-00	15 - 2	20P-F2327-00	17 - 7	5BP-F3873-01	21 - 1
38B-E111F-00	4 - 8	20P-E2481-00	6 - 16	1CK-E5514-00	12 - 1	38B-E8512-00	15 - 3	1CK-F3100-00	22 - 1	5BP-F3875-00	22 - 42
2FB-E1166-00	8 - 29	20P-E2482-00	6 - 18	38B-E5521-00	12 - 2	38B-E8513-00	15 - 4	1CK-F3102-00	22 - 2	20P-F411F-00	23 - 9
1CK-E1181-00	1 - 13	5ST-E2590-00	6 - 8	38B-E5524-10	12 - 5	38B-E8531-00	15 - 5	1CK-F3103-00	22 - 21	1CK-F413B-00	23 - 3
38B-E1185-01	5 - 4	5YP-E2671-00	6 - 7	21C-E5580-10	12 - 8	1CK-E8540-00	15 - 1	20P-F3110-00	22 - 8	5YY-F413B-00	23 - 2
1PA-E1191-00	1 - 6	5YP-E2675-00	6 - 6	38B-E5598-00	4 - 14	2FB-F1110-00	17 - 1		22 - 27	2GS-F414G-00	23 - 23
38B-E1193-00	1 - 9	38B-E3300-01	7 - 1	38B-E6111-00	13 - 1	1CK-F117G-00	17 - 9	20P-F3111-00	22 - 18	1CK-F416B-10	23 - 4
38B-E1196-00	5 - 5	38B-E3324-00	7 - 8	21C-E6135-10	13 - 18	1CK-F117K-00	24 - 11		22 - 37	20P-F4188-00	23 - 17
1PA-E1311-00	1 - 17	38B-E3327-00	7 - 13	54B-E6144-00	13 - 16	20P-F1338-00	17 - 8	20P-F3114-00	22 - 19	20P-F4191-00	23 - 8
38B-E1351-00	1 - 18	21C-E3362-00	2 - 13	1CK-E6150-00	13 - 5	1CK-F144G-00	31 - 36		22 - 38	2FB-F4244-00	23 - 7
1CK-E1400-09	2 - 1	38B-E3411-00	7 - 4	21C-E6154-00	13 - 6	1CK-F1511-00-1X	18 - 1	20P-F3118-00	22 - 17	2FB-F4245-00	23 - 5
2FB-E1454-00	2 - 14	38B-E3440-00	7 - 7	38B-E6193-00	13 - 2	1CK-F1511-00-6X	18 - 1		22 - 36	2FB-F4246-00	23 - 6
54B-E1476-00	2 - 12	38B-E3447-00	7 - 9	54B-E6321-00	13 - 8	1CK-F1511-00-7X	18 - 1	20P-F3125-00	22 - 4	20P-F4312-00	23 - 26
21C-E1496-20	2 - 9	2FB-E3556-00	8 - 2	21C-E6324-00	13 - 10	1CK-F160E-00	18 - 18		22 - 23	2FB-F4491-00	23 - 22
21C-E1531-01	2 - 15	2FB-E3557-00	8 - 8	21C-E6331-00	13 - 9	1CK-F1611-00	18 - 7	1CK-F3126-00	22 - 3	1CK-F4710-00	24 - 1
38B-E1536-10	2 - 8	2FB-E3585-00	8 - 1	21C-E6333-00	13 - 12	1CK-F1629-00	18 - 14	1CK-F3136-00	22 - 22	1PM-F4741-00	24 - 2
1PA-E1603-00	2 - 7	2FB-E3635-00	8 - 3	21C-E6337-00	13 - 13	1CK-F1640-00	18 - 13	20P-F3141-00	22 - 15	4LS-F4741-00	24 - 5
3C1-E1631-11	2 - 4	B12-E3750-00	8 - 11	3C1-E6344-00	13 - 17	2PB-F1650-00	20 - 21		22 - 34	1CK-F4750-00	24 - 4
38B-E1633-00	2 - 5	2FB-E3767-00	8 - 10	1CK-E6345-00	13 - 21	21C-F1681-00	18 - 9	20P-F3144-00	22 - 7	21C-F4763-00	24 - 6
38B-E1951-00	5 - 8	5D7-E3770-00	8 - 6	54B-E6351-00	13 - 11	1CK-F1711-00	19 - 1		22 - 26	20P-F4780-00	24 - 7
38B-E1952-01	5 - 9	2FB-E3907-00	23 - 21	21C-E6356-01	13 - 15	1CK-F171X-00-P1	19 - 26	20P-F3145-00	22 - 5	1CK-F478E-00	24 - 9
5YP-E2111-00	3 - 1	2FB-E3971-00	23 - 25	38B-E6357-01	13 - 22	1CK-F171X-00-P2	19 - 26		22 - 24	1CK-F510C-00	25 - 2
38B-E2113-00	3 - 4	5CA-E4147-00	8 - 7	21C-E6358-00	13 - 14	1CK-F171X-00-P3	19 - 26	20P-F3149-00	22 - 16	1CK-F5168-00-33	25 - 1
1PA-E2117-00	3 - 6	20P-E4411-00	8 - 13	21C-E6371-00	13 - 7	1CK-F1721-00	19 - 2		22 - 35	1CK-F5181-00	25 - 9
38B-E2119-00	3 - 3	20P-E4412-00	8 - 14	38B-E6380-01	13 - 20	2FB-F173E-00	19 - 17	20P-F3151-00	22 - 10	1CK-F5186-00	25 - 8
5YP-E2121-00	3 - 2	20P-E4419-00	8 - 23	38B-E7121-00	14 - 7	2FB-F173E-10	19 - 17		22 - 29	1CK-F530S-00	27 - 2
38B-E2126-00	3 - 7	20P-E441J-00	8 - 24	38B-E7131-00	14 - 5	2FB-F173E-20	19 - 17	20P-F3156-10	22 - 6	1CK-F531B-10	25 - 11
38B-E2151-00	3 - 8	20P-E443E-00	8 - 19	38B-E7151-00	14 - 2	2FB-F173F-00	19 - 19		22 - 25		27 - 26
1CK-E2156-00	3 - 14	2FB-E443H-00	8 - 33	38B-E7161-00	14 - 6	2FB-F173F-10	19 - 19	20P-F3157-00	22 - 11	1CK-F5338-00-33	27 - 1
2FB-E2157-00	4 - 7	20P-E4450-00	8 - 15	38B-E7211-00	14 - 13	2FB-F173F-20	19 - 19		22 - 30	54B-F5364-00	27 - 4
38B-E2161-00	3 - 11	3C1-E4452-00	8 - 17	38B-E7221-00	14 - 21	20P-F1749-00	33 - 8	21C-F3158-00	22 - 13	20P-F5366-00-33	27 - 6
38B-E2170-00	4 - 1	20P-E4453-01	8 - 16	38B-E7231-00	14 - 19	20P-F1773-00	33 - 17		22 - 32	1CK-F5377-00	27 - 9

INDICE NUMERICO
NUMERICAL INDEX

CODIGO Nº PART NO.	REF. Nº	CODIGO Nº PART NO.	REF. Nº	CODIGO Nº PART NO.	REF. Nº	CODIGO Nº PART NO.	REF. Nº	CODIGO Nº PART NO.	REF. Nº	CODIGO Nº PART NO.	REF. Nº
1CK-F5381-00	27 - 16	20P-F6257-00	29 - 9	2FB-F8393-00	34 - 31	1CK-H2589-01	43 - 22	5TS-H3936-01	30 - 20	2FB-XF41A-00-P1	23 - 1
1CK-F5383-00	27 - 18	2PB-F6280-01	34 - 15	2FB-F8393-10	34 - 31	2FB-H2590-00	42 - 13	20P-H3945-00	41 - 5	2FB-XF41A-00-P2	23 - 1
1CK-F5386-00	27 - 17	2PB-F6290-01	34 - 16	2FB-F8393-20	34 - 31	1CK-H2599-01	43 - 19	20P-H3951-00	41 - 8	2FB-XF835-00-P6	34 - 6
1CK-F5388-00	27 - 21	2FB-F6311-00	29 - 13	2FB-F8394-00	34 - 35	20P-H2911-00	41 - 3	1CK-H3963-00	41 - 2	2FB-XF835-10-P4	34 - 6
1CK-F5447-00	27 - 10	2FB-F6312-00	29 - 14	2FB-F8394-10	34 - 35	2FB-H3310-00	37 - 1	20P-H3972-01	41 - 1	2FB-XF835-20-P5	34 - 6
3C1-F5802-00	26 - 4	20P-F6315-00	29 - 15	2FB-F8394-20	34 - 35	2FB-H3311-00	37 - 3	2PB-H3975-00	41 - 2	2FB-XF836-00-P6	34 - 29
4S3-F5802-00	28 - 4	20P-F6335-00	29 - 17	20P-F8395-11	33 - 3	37 - 12	1CK-H3980-00	30 - 12	2FB-XF836-10-P3	34 - 29	
3GD-F5803-00	28 - 5	20P-F6372-00	29 - 18	2FB-F8398-00	34 - 32	37 - 22	54C-H4300-01	39 - 1	2FB-XF836-20-P0	34 - 29	
3C1-F5803-50	26 - 5	1CK-F7211-00	31 - 32	2FB-F8399-00	34 - 36	37 - 31	20P-H4312-01	39 - 8	2FB-XF83D-00-P3	33 - 12	
4S3-F5805-00	28 - 9	2YK-F7222-00	32 - 4	2FB-F841G-00	34 - 7	20P-H3318-00	37 - 4	20P-H4314-00	39 - 2	2FB-XF83G-00-P6	34 - 33
3C1-F5805-10	26 - 12	4TT-F7238-00	32 - 16	2FB-F841G-10	34 - 7	37 - 13	20P-H4345-00	39 - 9	2FB-XF83G-10-P3	34 - 33	
2FB-F580U-00	26 - 3	2FB-F7311-00	31 - 1	2FB-F841G-20	34 - 7	20P-H3318-10	37 - 23	20P-H4347-10	39 - 3	2FB-XF83G-20-P0	34 - 33
2FB-F580W-00	28 - 3	20P-F7411-00	31 - 10	2FB-F842G-00	34 - 8	37 - 32	2PB-H4359-00	39 - 15	2FB-XH250-00	42 - 15	
4ML-F582A-50	32 - 5	31 - 24	31 - 24	2FB-F842G-10	34 - 8	5YY-H3318-10	39 - 19	20P-H4378-00	39 - 4	90101-08006	27 - 22
1CK-F582U-00	26 - 1	1CK-F741L-00	31 - 48	2FB-F842G-20	34 - 8	37 - 38	20P-H4397-00	39 - 7	90105-06169	23 - 12	
1CK-F582W-00	28 - 1	1CK-F742L-00	31 - 49	2FB-F843G-00	33 - 13	54B-H331A-00	37 - 2	20P-H4544-01	39 - 6	90105-08850	1 - 10
1CK-F583T-00	30 - 2	20P-F7431-00	31 - 42	2FB-F844G-00	33 - 14	20P-H331B-00	41 - 6	20P-H4544-11	39 - 5	90105-10006	21 - 11
1CK-F583V-00	32 - 1	20P-F7435-00	31 - 14	20P-F8483-00	34 - 17	1CK-H331E-00	37 - 5	1CK-H4547-00	40 - 6	90105-10082	26 - 14
3C1-F5852-00	30 - 5	31 - 28	31 - 28	20P-F8484-00	34 - 18	2FB-H3320-00	37 - 10	1CK-H4710-00	40 - 1	90105-10311	20 - 13
54C-F5852-00	32 - 9	20P-F7441-00	31 - 43	2FB-H1410-00	35 - 2	54B-H332A-00	37 - 11	1CK-H4726-00	40 - 5	90105-10323	17 - 2
20P-F5854-00	32 - 11	20P-F7442-00	31 - 8	2FB-H1450-00	35 - 1	1CK-H332E-00	37 - 14	1CK-H4740-00	40 - 4	90105-106A7	31 - 3
3RW-F5854-00	30 - 4	20P-F7443-00	31 - 22	38B-H1800-01	36 - 1	2FB-H3330-00	37 - 20	1CK-H4744-00	40 - 7	90105-10857	17 - 3
3C1-F5855-00	30 - 8	2FB-F7445-00	31 - 19	3AY-H1801-00	36 - 2	20P-H3333-00	37 - 8	5US-H5110-00	43 - 28	90109-06183	19 - 9
20P-F585B-00	32 - 10	2FB-F7446-00	31 - 39	3AY-H1828-00	36 - 5	37 - 17	2FB-H5546-00	43 - 2	90109-06259	16 - 2	
2VN-F5866-00	32 - 6	20P-F7451-00	31 - 9	1S7-H1861-00	36 - 4	37 - 27	2FB-H591A-00	43 - 1	90109-06577	30 - 10	
3RW-F5867-00	30 - 7	20P-F7461-00	31 - 23	1CK-H1940-01	43 - 10	37 - 36	2FB-H592A-00	43 - 7	90109-06887	18 - 8	
20P-F5872-00	30 - 1	1CK-F8100-10	17 - 10	2FB-H1950-00	43 - 15	54B-H333A-00	37 - 21	5P0-W0041-10	30 - 3	90109-08015	28 - 2
2FB-F5873-00	32 - 22	20P-F811G-00	42 - 6	1CK-H1950-01	43 - 16	1CK-H333E-00	37 - 24	20P-W0042-00	32 - 2	90110-05806	23 - 19
20P-F5876-00	30 - 19	1CK-F8186-00	17 - 11	54B-H1960-00	43 - 8	2FB-H3340-00	37 - 29	4C9-W0048-00	26 - 6	90110-06215	23 - 15
1CK-F5886-00	30 - 17	20P-F8284-00	17 - 5	20P-H2100-00	42 - 4	54B-H334A-00	37 - 30	4S3-W0048-00	28 - 6	90110-06287	23 - 13
20P-F5894-00	32 - 8	54C-F831U-00	33 - 10	1CK-H2115-00	42 - 7	1CK-H334E-00	37 - 33	2FB-WF461-00	23 - 18	90110-08814	31 - 18
1CK-F5895-00	32 - 14	20P-F832U-01	33 - 11	1CK-H2116-00	42 - 9	5TS-H3350-01	43 - 24	1CK-WF47E-00	24 - 10	31 - 38	31 - 38
3FV-F589A-00	32 - 15	2FB-F8356-00	34 - 12	1CK-H2121-00	42 - 5	1CK-H3371-00	43 - 26	1CK-XF11E-20-P2	34 - 22	90110-10012	31 - 16
3SP-F5914-51	28 - 8	1CK-F836B-00	19 - 24	20P-H2133-00	37 - 9	1CK-H3371-10	43 - 25	1CK-XF11E-20-P5	34 - 22	31 - 30	31 - 30
5YP-F5917-00	26 - 8	20P-F836B-00	19 - 24	37 - 18	37 - 18	2FB-H3500-00	38 - 1	1CK-XF11E-30-P3	34 - 22	90111-05002	34 - 43
4S3-F5919-00	28 - 7	1CK-F836M-00-P1	33 - 12	37 - 28	37 - 28	20P-H3546-00	41 - 7	1CK-XF11F-20-P2	34 - 23	90111-05003	19 - 7
5P0-F5919-00	26 - 10	1CK-F836M-00-P2	33 - 12	37 - 37	37 - 37	52B-H3591-00	43 - 5	1CK-XF11F-20-P5	34 - 23	33 - 19	33 - 19
5YP-F5924-00	26 - 11	20P-F836R-00	34 - 2	20P-H213A-00	37 - 7	20P-H3592-00	38 - 5	1CK-XF11F-30-P3	34 - 23	34 - 28	34 - 28
5YP-F5925-01	26 - 9	20P-F837L-00	34 - 41	37 - 16	37 - 16	1CK-H3595-00	38 - 7	2FB-XF173-00-P5	19 - 16	34 - 39	34 - 39
5YP-F5937-00	26 - 7	20P-F837M-00	34 - 42	37 - 26	37 - 26	1CK-H3596-00	38 - 9	2FB-XF173-10-P5	19 - 16	90111-06117	18 - 4
5YP-F5939-00	26 - 13	1CK-F8381-00	34 - 1	37 - 35	37 - 35	20P-H3618-00	37 - 6	2FB-XF173-20-P0	19 - 16	33 - 4	33 - 4
20P-F6121-00	29 - 1	20P-F8385-10	33 - 2	1P5-H2310-10	42 - 1	37 - 15	2FB-XF174-00-P5	19 - 18	19 - 18	34 - 24	34 - 24
20P-F6122-00	29 - 2	2FB-F8391-00	34 - 30	20P-H2370-02	42 - 3	37 - 25	2FB-XF174-10-P5	19 - 18	90111-06139	20 - 22	20 - 22
20P-F622F-00	29 - 11	2FB-F8391-10	34 - 30	20P-H246B-02	43 - 20	37 - 34	2FB-XF174-20-P0	19 - 18	90111-06826	9 - 7	9 - 7
20P-F622H-00	29 - 10	2FB-F8391-20	34 - 30	54C-H2501-00	42 - 10	1CK-H3755-01	38 - 6	1CK-XF17C-10-P1	19 - 23	90111-08836	34 - 13
1CK-F6240-00	29 - 6	2FB-F8392-00	34 - 34	1CK-H2509-00	42 - 8	20P-H3912-00	41 - 4	1CK-XF17C-10-P3	19 - 23	90111-08847	26 - 2
20P-F6241-00	29 - 7	2FB-F8392-10	34 - 34	1CK-H2530-00	42 - 12	38B-H3922-00	30 - 9	1CK-XF17C-20-P2	19 - 23	90116-08826	27 - 11
20P-F6246-00	29 - 8	2FB-F8392-20	34 - 34	21C-H2540-00	43 - 3	20P-H3927-00	41 - 9	2FB-XF41A-00-P0	23 - 1	90119-06054	43 - 21

INDICE NUMERICO
NUMERICAL INDEX

CODIGO Nº PART NO.	REF. Nº	CODIGO Nº PART NO.	REF. Nº	CODIGO Nº PART NO.	REF. Nº	CODIGO Nº PART NO.	REF. Nº	CODIGO Nº PART NO.	REF. Nº	CODIGO Nº PART NO.	REF. Nº
90119-06137	32 - 21	90201-20814	14 - 22	90430-06014	1 - 8	90480-18549	23 - 14	93102-12809	16 - 8	94568-A8096	4 - 10
90119-06209	8 - 28	90201-25290	12 - 7		1 - 20	90480-18859	18 - 5	93102-12877	13 - 25	94568-E5132	27 - 24
90119-06233	18 - 6	90202-05180	33 - 20	90430-10148	43 - 4	90480-25482	18 - 19	93102-20806	14 - 26	94668-E5021	27 - 25
90149-06118	42 - 11		34 - 27	90430-10802	43 - 6	90501-06800	15 - 6	93103-10804	5 - 2	94703-00318	1 - 12
90149-06829	4 - 13		34 - 40	90445-08831	19 - 12	90501-12743	31 - 44	93106-17802	20 - 16	95022-06010	1 - 3
90150-05024	34 - 3	90202-26142	21 - 7	90445-08832	19 - 13	90501-18576	7 - 5	93106-22808	25 - 3		1 - 19
90159-06181	19 - 3	90208-20003	13 - 27	90445-105G5	23 - 30	90506-20193	31 - 34		27 - 5		4 - 9
	19 - 20	90209-10020	21 - 12	90445-12804	6 - 20	90506-28800	31 - 2	93106-26801	27 - 8		14 - 29
	19 - 25	90209-17285	14 - 3	90445-16807	31 - 35	90508-183B9	31 - 11	93210-09809	4 - 3	95022-06012	5 - 12
90163-05803	8 - 18	90209-18208	14 - 16	90445-21848	31 - 7	90508-184E0	31 - 25	93210-14812	11 - 6		7 - 14
90170-05302	3 - 10	90214-10006	2 - 11	90450-27803	6 - 17	90508-32837	16 - 5	93210-15620	32 - 7		38 - 8
	3 - 13	90215-10284	2 - 20		6 - 19	90520-02810	34 - 5	93210-19809	5 - 16	95022-06014	30 - 18
90170-10012	2 - 21	90240-08005	32 - 17	90450-39806	8 - 31	90520-08801	19 - 27		11 - 18		38 - 10
90179-04003	40 - 9	90240-08800	31 - 12	90450-48805	8 - 12	91312-05008	43 - 11	93210-26810	36 - 6	95022-06016	11 - 11
90179-05804	34 - 4		31 - 26	90464-05802	33 - 1	91312-05010	23 - 20	93210-32807	8 - 4	95022-06020	1 - 7
90179-10811	17 - 4		31 - 46		34 - 11		23 - 24	93210-32813	11 - 8		6 - 3
90179-10813	20 - 15	90249-02002	31 - 15	90464-10801	23 - 27	91312-06016	35 - 4	93210-34805	7 - 6		7 - 10
90179-12802	13 - 4		31 - 29	90464-17003	32 - 25	91312-06020	4 - 19	93210-54806	7 - 12		8 - 5
90179-14001	13 - 19	90269-06814	19 - 5	90464-20815	34 - 10		12 - 9	93210-84802	5 - 6	95022-06025	5 - 11
90179-25615	21 - 6		19 - 21	90464-20822	43 - 23	91312-06025	35 - 3	93306-000Y5	5 - 10		5 - 14
90183-05076	24 - 14	90280-03017	2 - 3	90464-24802	29 - 19	91312-06030	29 - 12	93306-001X7	4 - 4	95022-06040	10 - 6
90183-050A7	19 - 6	90282-05031	2 - 19	90464-36800	43 - 18	91312-06100	1 - 16	93306-003YN	14 - 24		11 - 4
	33 - 9	90338-09802	30 - 13	90464-50800	43 - 17	91317-06020	29 - 4	93306-004XX	14 - 8		11 - 15
	34 - 9	90338-16008	8 - 25	90467-08003	19 - 14	91317-06025	34 - 19	93306-054Y5	27 - 7	95022-06045	10 - 4
90183-05818	19 - 22	90340-12813	1 - 2	90467-09006	23 - 28	91317-08025	29 - 3	93306-202YD	2 - 17	95022-06050	5 - 15
	34 - 38	90340-14824	11 - 5		23 - 29	91317-08030	21 - 10	93306-202YE	14 - 9		11 - 16
	39 - 11	90340-32823	11 - 7	90467-10808	6 - 21	91380-06016	9 - 10	93306-203XS	2 - 18	95022-06055	10 - 3
90183-05M01	9 - 4	90387-06023	9 - 6	90467-12085	32 - 13	91401-20012	16 - 13	93306-204Y6	14 - 25	95022-06070	10 - 5
90183-06822	8 - 27	90387-064W3	6 - 12	90467-12800	8 - 20		31 - 13	93306-252YH	25 - 4	95022-06080	7 - 11
90201-047A2	43 - 14	90387-06890	23 - 16	90467-13802	8 - 32		31 - 27		27 - 3	95022-06090	11 - 20
90201-05036	38 - 2	90387-068B2	23 - 10	90467-13816	8 - 30		31 - 47	93306-305X7	2 - 2	95027-06025	30 - 14
	39 - 13	90387-068C2	33 - 6	90467-20050	8 - 22		32 - 19	93306-906Y0	4 - 2	95301-08700	32 - 3
90201-05725	43 - 30		34 - 20	90467-23059	8 - 26	91810-14809	1 - 14	93306-906Y1	4 - 2	95307-06600	18 - 11
90201-06072	6 - 11		34 - 25	90480-01558	19 - 4		1 - 15	93310-325X3	12 - 6	95602-05100	43 - 29
90201-06078	18 - 12	90387-068C4	34 - 44		34 - 14		10 - 2	93315-112Y9	13 - 24	95602-06100	30 - 11
90201-08066	32 - 18	90387-068C8	18 - 2		34 - 26		11 - 3	93315-31758	20 - 11	95602-06200	18 - 17
90201-08609	1 - 11	90387-068G0	18 - 16	90480-01559	33 - 18		11 - 14	93317-318Y5	20 - 2	95602-08200	27 - 12
90201-08612	9 - 15		20 - 18	90480-01803	6 - 13	92012-06010	31 - 37	93410-20809	14 - 4	95602-14200	25 - 10
90201-10066	31 - 17	90387-068H0	20 - 23	90480-01811	33 - 7	92012-06020	31 - 20	93410-22039	14 - 17		27 - 19
	31 - 31	90387-07819	20 - 8	90480-10805	9 - 11		31 - 40	93450-16115	2 - 6	95612-08640	1 - 5
90201-10118	30 - 16		20 - 26	90480-12581	9 - 5	92012-08012	24 - 3	93501-04805	31 - 45	95617-10100	31 - 6
	32 - 24	90387-08812	31 - 51	90480-12805	18 - 3	92012-08020	32 - 20	93505-16844	13 - 23	95702-08500	9 - 13
90201-105E8	12 - 3	90387-10003	31 - 4	90480-13818	40 - 3	92902-06200	16 - 12	93608-30839	16 - 7		27 - 23
90201-12019	13 - 3	90387-10814	20 - 12	90480-14003	33 - 5	92902-06600	31 - 21	93822-15808	14 - 27	95702-12500	35 - 5
	35 - 6	90387-15810	2 - 16	90480-14229	39 - 12		31 - 41	93900-00824	25 - 6	95707-06500	24 - 8
90201-15022	2 - 10	90401-10820	30 - 15	90480-14816	38 - 4	92907-10600	31 - 5		27 - 14	95707-12500	20 - 6
90201-15837	27 - 20		32 - 23	90480-15363	6 - 9	92990-06200	9 - 9	94109-17803	25 - 5	95802-06020	43 - 9
90201-173F4	14 - 23	90430-06014	1 - 4	90480-15483	23 - 11	93101-10805	11 - 19	94113-17806	27 - 13	95812-06030	8 - 9

INDICE NUMERICO
NUMERICAL INDEX

CODIGO N° PART NO.	REF. N°	CODIGO N° PART NO.	REF. N°	CODIGO N° PART NO.	REF. N°	CODIGO N° PART NO.	REF. N°	CODIGO N° PART NO.	REF. N°	CODIGO N° PART NO.	REF. N°
95812-08012	31 - 50										
95812-08016	9 - 14										
95812-08040	9 - 16										
95817-08016	17 - 6										
95822-06012	43 - 27										
95822-06025	6 - 10										
95827-06014	20 - 9										
	20 - 19										
	20 - 25										
97002-06016	42 - 2										
97024-06020	16 - 15										
97607-06214	18 - 10										
97702-40012	43 - 13										
97702-50014	40 - 2										
97702-50016	18 - 15										
97707-50012	19 - 28										
	33 - 16										
	34 - 37										
97707-50016	38 - 3										
	39 - 10										
	39 - 14										
98502-05025	7 - 2										
98507-05012	24 - 13										
	29 - 16										
98507-05020	24 - 12										
98512-06012	14 - 11										
98707-03020	41 - 11										
98707-04045	32 - 12										
98907-04020	40 - 8										
99001-10600	16 - 6										
99009-10400	12 - 4										
99009-20500	13 - 26										
99241-00140	33 - 15										